**Road vehicles — Compressed natural
gas (CNG) refuelling connector —**

**Part 1:
20 MPa (200 bar) connector**

*Véhicules routiers — Connecteur de remplissage en gaz naturel
comprimé (GNC) —*
Partie 1: Connecteur 20 MPa (200 bar)

[ISO 14469-1:2004](https://standards.iso.org/iso/14469-1:2004)

<https://standards.iteh.ai/catalog/standards/sist/704cc710-1881-45f7-aca1-5c315c458a89/iso-14469-1-2004>



PDF disclaimer

This PDF file may contain embedded typefaces. In accordance with Adobe's licensing policy, this file may be printed or viewed but shall not be edited unless the typefaces which are embedded are licensed to and installed on the computer performing the editing. In downloading this file, parties accept therein the responsibility of not infringing Adobe's licensing policy. The ISO Central Secretariat accepts no liability in this area.

Adobe is a trademark of Adobe Systems Incorporated.

Details of the software products used to create this PDF file can be found in the General Info relative to the file; the PDF-creation parameters were optimized for printing. Every care has been taken to ensure that the file is suitable for use by ISO member bodies. In the unlikely event that a problem relating to it is found, please inform the Central Secretariat at the address given below.

iTeh STANDARD PREVIEW
(standards.iteh.ai)

[ISO 14469-1:2004](#)

<https://standards.iteh.ai/catalog/standards/sist/704cc710-1881-45f7-aca1-5c315c458a89/iso-14469-1-2004>

© ISO 2004

All rights reserved. Unless otherwise specified, no part of this publication may be reproduced or utilized in any form or by any means, electronic or mechanical, including photocopying and microfilm, without permission in writing from either ISO at the address below or ISO's member body in the country of the requester.

ISO copyright office
Case postale 56 • CH-1211 Geneva 20
Tel. + 41 22 749 01 11
Fax + 41 22 749 09 47
E-mail copyright@iso.org
Web www.iso.org

Published in Switzerland

Contents

Page

Foreword	iv
Introduction	v
1 Scope	1
2 Normative references	1
3 Terms and definitions	1
4 General construction requirements	2
5 Nozzles	3
6 Standard receptacle dimensions	4
7 Receptacles	5
8 Instructions	5
9 Marking	6
10 Tests	6
Annex A (informative) Nozzle characteristics	20
Annex B (informative) Manufacturing and production test plan	21
Annex C (normative) Receptacle test fixture	22

<https://standards.iteh.ai/catalog/standards/sist/704cc710-1881-45f7-aca1-5c315c458a89/iso-14469-1-2004>

Foreword

ISO (the International Organization for Standardization) is a worldwide federation of national standards bodies (ISO member bodies). The work of preparing International Standards is normally carried out through ISO technical committees. Each member body interested in a subject for which a technical committee has been established has the right to be represented on that committee. International organizations, governmental and non-governmental, in liaison with ISO, also take part in the work. ISO collaborates closely with the International Electrotechnical Commission (IEC) on all matters of electrotechnical standardization.

International Standards are drafted in accordance with the rules given in the ISO/IEC Directives, Part 2.

The main task of technical committees is to prepare International Standards. Draft International Standards adopted by the technical committees are circulated to the member bodies for voting. Publication as an International Standard requires approval by at least 75 % of the member bodies casting a vote.

Attention is drawn to the possibility that some of the elements of this document may be the subject of patent rights. ISO shall not be held responsible for identifying any or all such patent rights.

ISO 14469-1 was prepared by Technical Committee ISO/TC 22, *Road vehicles*, Subcommittee SC 25, *Road vehicles using natural gas*.

ISO 14469 consists of the following parts, under the general title *Road vehicles — Compressed natural gas (CNG) refuelling connector*:

— *Part 1: 20 MPa (200 bar) connector*

Size 2 and 25 MPa (250 bar) connectors will form the subjects of future parts 2 and 3.

iTeh STANDARD PREVIEW
(standards.iteh.ai)

[ISO 14469-1:2004](https://standards.iteh.ai/catalog/standards/sist/704cc710-1881-45f7-aca1-5c315c458a89/iso-14469-1-2004)

<https://standards.iteh.ai/catalog/standards/sist/704cc710-1881-45f7-aca1-5c315c458a89/iso-14469-1-2004>

Introduction

This part of ISO 14469 was developed to use in the examination, testing and certification of newly produced compressed natural (CNG) gas vehicle fuelling nozzles and receptacles and, as such, applies only to the nozzles and receptacles used in CNG fuelling systems, and not to the system itself.

A nozzle certified to this part of ISO 14469 will be functionally compatible from a safety and performance perspective with all listed receptacles of compatible profile and system pressure. Similarly, a certified receptacle will be functionally compatible from a safety and performance perspective with all listed nozzles of compatible profile and system pressure.

As there may eventually be many different kinds of nozzles and receptacles available from a variety of manufacturers which, for safety reasons, must all be compatible with one another, this part of ISO 14469 specifies a series of receptacle profiles. These standard profiles incorporate the design specifications (mating materials, geometry and tolerances) which may be considered in the certification of a submitted nozzle or receptacle. This part of ISO 14469 refers only to one working pressure and one application. Other working pressures and applications are under consideration for the future.

The construction and performance of nozzles and receptacles are based on the observation that three main parameters affect user safety and system compatibility.

a) Working pressure

All nozzles and receptacles are designed to have a working pressure of 25 MPa (250 bar).

b) Design life

Frequency of use is the second parameter to be considered. Since frequency of use will differ with the nozzle/receptacle application (i.e. public sector, fleet employee and residential), all receptacles will be tested at 10 000 connect/disconnect cycles for compliance with this part of ISO 14469. In addition, all nozzles will be tested according to the following frequency use classifications, as applicable:

- 1) Class A Nozzle, specifying high frequency use, with a cycle life of 100 000 cycles and equating to approximately 100 fills per day for three years;
- 2) Class B Nozzle, specifying medium frequency use, with a cycle life of 20 000 cycles and equating to approximately 10 fills per day for five years.

c) Training

Operator training required is in accordance with national requirements.

iTeh STANDARD PREVIEW
(standards.iteh.ai)

ISO 14469-1:2004

<https://standards.iteh.ai/catalog/standards/sist/704cc710-1881-45f7-aca1-5c315c458a89/iso-14469-1-2004>

Road vehicles — Compressed natural gas (CNG) refuelling connector —

Part 1: 20 MPa (200 bar) connector

1 Scope

This part of ISO 14469 specifies CNG refuelling nozzles and receptacles constructed entirely of new and unused parts and materials, for road vehicles powered by compressed natural gas. A CNG refuelling connector consists of, as applicable, the receptacle and its protective cap (mounted on the vehicle) and the nozzle. This part of ISO 14469 is applicable only to such devices designed for a service pressure of 20 MPa (200 bar), identified by the code B200, to those using CNG in accordance with ISO 15403 and having standardized mating components, and to connectors that prevent natural gas vehicles from being fuelled by dispenser stations with service pressures higher than that of the vehicle, while allowing them to be fuelled by stations with service pressures less than or equal to the vehicle fuel system service pressure.

NOTE All references to pressures, given in megapascals and bar (1 bar = 0,1 MPa = 10^5 Pa; 1 MPa = 1 N/mm²) are to be considered gauge pressures, unless otherwise specified.

<https://standards.iteh.ai/catalog/standards/sist/704cc710-1881-45f7-aca1-5c315c458a89/iso-14469-1-2004>

2 Normative references

The following referenced documents are indispensable for the application of this document. For dated references, only the edition cited applies. For undated references, the latest edition of the referenced document (including any amendments) applies.

ISO 188:1982, *Rubber, vulcanized — Accelerated ageing or heat-resistance tests*

ISO 1817:1985, *Rubber, vulcanized — Determination of the effect of liquids*

ISO 9227:1990, *Corrosion tests in artificial atmospheres — Salt spray tests*

ISO 15403, *Natural gas — Designation of the quality of natural gas for use as a compressed fuel for vehicles*

ISO 15501-1, *Road vehicles — Compressed natural gas (CNG) fuel systems — Part 1: Safety requirements*

3 Terms and definitions

For the purposes of this document, the following terms and definitions apply.

3.1 dry air

air with moisture content such that the dew point of the air at the required test pressure is at least 11 °C below the ambient test temperature

- 3.2 hydrostatic pressure**
pressure to which a component is taken to verify the structural strength of the component
- 3.3 working pressure**
maximum pressure that a CNG refuelling connector can be expected to withstand in actual service
- 3.4 service pressure**
settled pressure of 20 MPa (200 bar) at a uniform gas temperature of 15 °C
- 3.5 positive locking means**
feature which requires actuation of an interlocking mechanism to allow connection/disconnection of the nozzle from the receptacle
- 3.6 CNG refuelling nozzle**
device which permits quick connection and disconnection of fuel supply hose to the CNG receptacle in a safe manner
- 3.7 CNG refuelling receptacle**
device connected to a vehicle or storage system which receives the CNG refuelling nozzle and permits safe transfer of fuel
- 3.8 CNG refuelling connector**
joined assembly of CNG refuelling nozzle and receptacle

iTeh STANDARD PREVIEW
(standards.iteh.ai)

ISO 14469-1:2004
<https://standards.iteh.ai/catalog/standards/sist/704cc710-1881-45f7-aca1-5c315c458a89/iso-14469-1-2004>

4 General construction requirements

- 4.1** CNG refuelling nozzles (hereafter referred to as CNG nozzles) and receptacles (hereinafter both also referred to as devices) manufactured in accordance with this part of ISO 14469 shall be designed in accordance with reasonable concepts of safety, durability and maintainability.
- 4.2** CNG nozzles and receptacles shall be well fitted and manufactured in accordance with good engineering practice. All construction requirements may be met by either the construction specified in this part of ISO 14469 or another construction that gives at least equivalent performance.
- 4.3** CNG nozzles and receptacles shall be
- designed to minimize the possibility of incorrect assembly,
 - designed to be secure against displacement, distortion, warping or other damage, and
 - constructed to maintain operational integrity under normal and reasonable conditions of handling and usage.
- 4.4** CNG nozzles and receptacles shall be manufactured of materials suitable and compatible for use with CNG at the pressure and the temperature ranges to which they will be subjected (see Clause 1).

The minimum temperature range shall be selected by the manufacturer between the following ranges:

- 40 °C to 85 °C
- 20 °C to 120 °C

- 4.5** CNG nozzles and receptacles constructed of brass shall use brass alloys with a copper mass content ≤ 70 %. This will ensure proper material compatibility with all the constituents of natural gas.
- 4.6** Separate external three-way valves shall be constructed and marked so as to indicate clearly the open, shut and vent positions.
- 4.7** CNG nozzles and receptacles shall be operated either to connect or disconnect without the use of tools.
- 4.8** The receptacle shall be mounted on the vehicle in accordance with ISO 15501-1.
- 4.9** Jointing components shall provide gas-tight sealing performance.

5 Nozzles

5.1 Nozzles shall be one of the three types according to a), b) and c). See also Annex A.

- a) Type 1 is a nozzle for use with dispensing hoses that remain fully pressurized at dispenser shutdown. The nozzle shall not allow gas to flow until a positive connection has been achieved. The nozzle shall be equipped with an integral valve or valves, incorporating an operating mechanism which first stops the supply of gas and safely vents the trapped gas before allowing the disconnection of the nozzle from the receptacle. The operating mechanism shall ensure that the vent valve is in the open position before the release mechanism can be operated and that the gas located between the nozzle shut-off valve and the receptacle check valve is safely vented prior to nozzle disconnection (see 10.2).
- b) Type 2 is a nozzle for use with dispensing hoses that remain fully pressurized at dispenser shutdown. A separate three-way valve connected directly, or indirectly, to the inlet of the nozzle is required to safely vent trapped gas prior to nozzle disconnection. The nozzle shall not permit the flow of gas if unconnected. Venting is required prior to disconnection of the nozzle (see 10.2).
- c) Type 3 is a nozzle for use with dispensing hoses which are automatically depressurized — 0,5 MPa (5 bar) and below — at dispenser shutdown (see 10.2).

In addition, nozzles shall be classified in terms of cycle life as follows:

- Class A, specifying high frequency use, with a cycle life of 100 000;
- Class B, specifying low frequency use, with a cycle life of 20 000.

5.2 Venting or de-pressurization of all nozzle types is required prior to disconnection. Disconnection of all nozzles shall be able to be accomplished in accordance with 10.2.

5.3 The method for attaching the nozzle to the fuel dispensing system hose shall not rely on the joint threads between the male and female threads for sealing (e.g. conical threads).

5.4 The three-way valve exhaust port of Type 1 and Type 2 nozzles shall be protected from the ingress of foreign particles and fluid which would hamper the operation of the valve.

5.5 The portions of a nozzle which are held by the user for connection or disconnection may be thermally insulated.

5.6 A Type 1 nozzle shall bear a marking in accordance with Clause 9, if necessary indicating the direction of the open and shut operation of the actuating mechanism.

5.7 The interface surface of the nozzle shall be constructed of material having a hardness > 75 Rockwell B (HRB 75) and shall be non-sparking and conductive (see 10.11.5 and 10.15).

The exposed surfaces of the nozzles shall be made of non-sparking materials (see 10.11.5 and 10.15).

5.8 Nozzles shall comply with the performance requirements of Clause 10 to ensure interchangeability.

6 Standard receptacle dimensions

A receptacle shall comply with the design specifications shown in Figure 1.

Dimensions in millimetres
Surface roughness $\leq Ra\ 3,2\ \mu\text{m}$

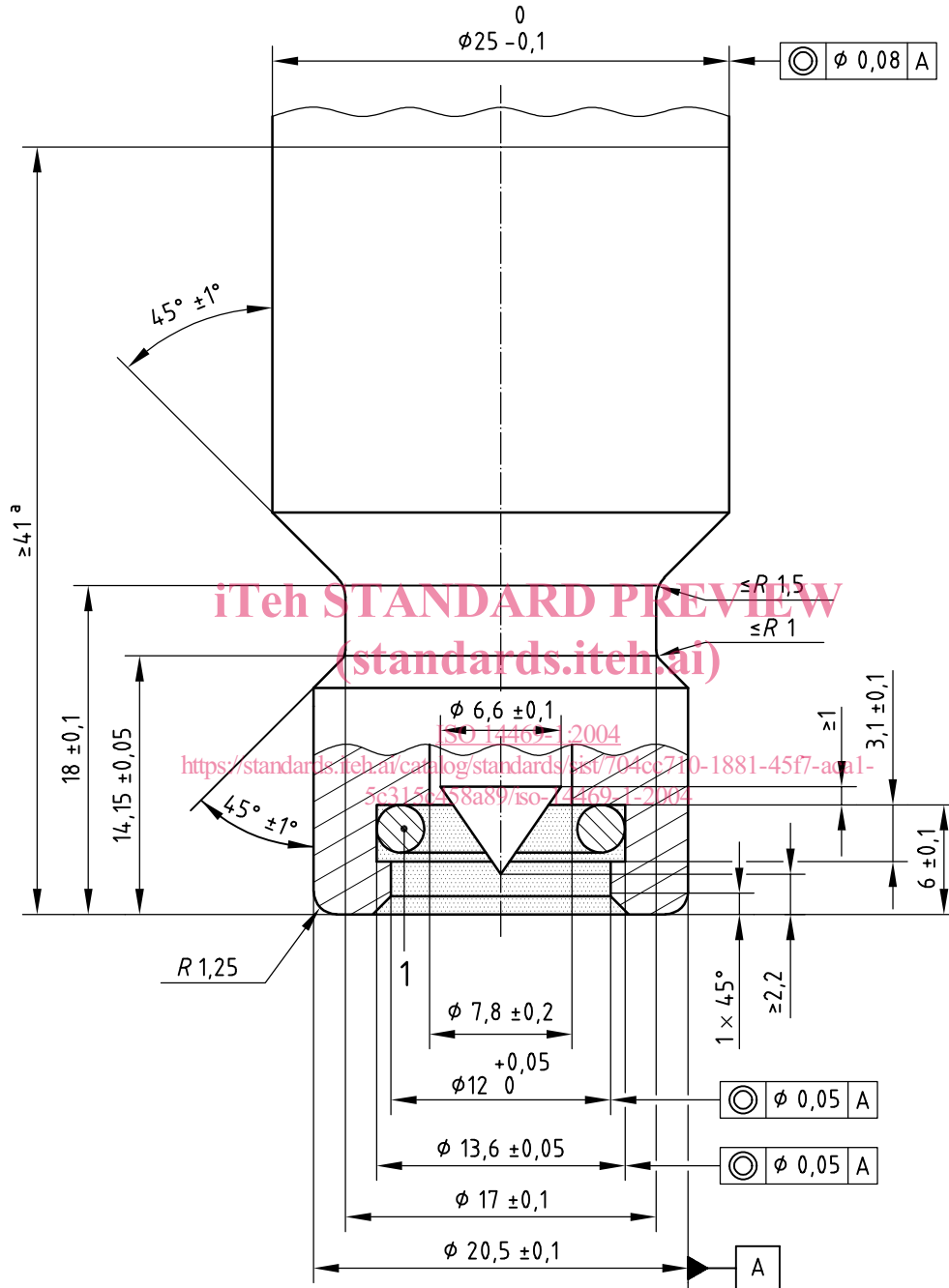

Key

 This area shall be kept free of all components.

- 1 Sealing surface equivalent to No. 110 O-ring of dimensions:
9,19 mm \pm 0,127 mm ID
2,62 mm \pm 0,076 mm width

Sealing surface finish: 0,8 μm to 0,05 μm
Material hardness: 75 Rockwell B (HRB 75) minimum

^a Minimum length of the receptacle which is clear of provisions for attachment of receptacle or protective caps.

Figure 1 — B200 receptacle

7 Receptacles

7.1 Receptacles shall comply with Clauses 1 to 10 and shall be evaluated using at least two different test nozzles, each nozzle representing a different locking technology.

The failure of any test conducted with the receptacle and nozzle test samples shall constitute a failure of the submitted receptacle, unless the manufacturer can prove the problem was caused by the test nozzle.

7.2 Receptacle designs which employ means, on the back diameter as shown in Figure 1, to accommodate mounting, or for mounting accessories or marking purposes, shall not have such means extend beyond the back diameter dimensions of the profile as specified by Figure 1, as applicable. *Acceptable means* include wrench flats, dust cap anchoring grooves, use of hex stock, undercutting for marking, and threads for pressure-tight caps. Receptacle designs shall not compromise the interchangeability requirements specified in Annex C.

7.3 The receptacle shall be equipped with an internal check valve to prevent the escape of gas. The check valve shall be of the non-contact type, opening by differential pressure only.

7.4 The method for attaching the receptacle to the vehicle fuel system shall not rely on the joint between the male and female threads for sealing, such as conical threads.

7.5 The interfacing surface of the receptacle shall be constructed of material having a hardness > 75 Rockwell B (HRB 75) and shall be non-sparking and conductive (see 10.11.5 and 10.15).

The exposed surfaces of devices shall be made of non-sparking materials (see 10.11.5).

7.6 Receptacles shall have a means to prevent the ingress of fluids and foreign matter.

7.7 The function specified in 7.6 may also be met by either a protective cap (see 10.4) or a pressure-tight protective cap (see 10.16).

7.8 The receptacle shall have provisions to be firmly attached to the vehicle and shall comply with applicable abnormal load tests (see 10.7).

7.9 The receptacle shall not be installed in an area in which the temperature exceeds 85 °C.

7.10 Receptacles shall have a cycle life of > 10 000 cycles.

8 Instructions

8.1 Information required under this clause for instructions and provisions to be specified shall be given in an easily understood form.

8.2 Special tools required for connection of receptacles to tubing and assembly and disassembly of three-way valve parts shall be clearly identified in the instructions.

8.3 The manufacturers of receptacles, nozzles and three-way valves shall provide clear and concise printed instructions and diagrams in a form that can be easily understood and adequate for

- a) proper field assembly,
- b) installation,
- c) maintenance,
- d) replacement of components as appropriate,

- e) safe operation by all users,
- f) suitability and use, and
- g) storage and handling.

9 Marking

9.1 Information required under this clause to be marked shall be in an easily understood form. Marking should be embossed, cast, stamped or otherwise formed in the part. This includes markings baked into an enamelled surface.

9.2 Nozzles and receptacles shall bear the following information:

- a) manufacturer's or dealer's name, trademark or symbol;
- b) model designation;
- c) B200;
- d) applicable type and class (see 5.1).

9.3 Nozzles and receptacles shall each bear a date code marking.

The four-digit date code marking shall consist of at least four adjacent digits determined as follows.

- a) The first and second digits shall indicate the calendar year in which the nozzle, receptacle or three-way valve was manufactured (e.g. 96 for 1996, 00 for 2000).
- b) The third and fourth digits shall indicate the week in which the nozzle, receptacle or three-way valve was manufactured (e.g. 03 for the third week of the year). For the purpose of this marking, a week shall begin at 00:01 h on Sunday and end at 24:00 h on Saturday.

A date code may be used for more than one week. However, it shall not be used for more than four consecutive weeks, or for more than two weeks into the next calendar year.

When a four-digit date code is not practical, the manufacturer shall submit a plan acceptable to the certifying agency which will outline means of establishing the date of manufacture so that it is traceable to the purchaser.

Additional numbers, letters or symbols may follow the four digit number specified in a) and b). If additional numbers are used, they shall be separated from the date code.

9.4 Marking to identify this part of ISO 14469 shall be provided for each system. This marking may be located on the package or on a notice placed inside the package in which the device is shipped.

10 Tests

10.1 General requirements

The nozzle and receptacle tested shall be of the receptacle and nozzle designs specified in Clauses 1 to 9.

Unless otherwise stated,

- a) tests shall be conducted at room temperature (20 ± 5) °C,
- b) all pressure or leak tests shall be conducted with dry air or dry nitrogen, and
- c) devices shall be conditioned to attain equilibrium conditions.