



SLOVENSKI STANDARD

SIST EN 61754-7-1:2014

01-december-2014

Nadomešča:
SIST EN 61754-7:2008

**Optični spojni elementi in pasivne komponente - Vmesniki optičnih konektorjev - 7
-1. del: Družina konektorjev vrste MPO - Vlakna enoredno (IEC 61754-7-1:2014)**

Fibre optic interconnecting devices and passive components - Fibre optic connector interfaces - Part 7-1: Type MPO connector family - One fibre row

iTeh STANDARD PREVIEW
(standards.iteh.ai)

[SIST EN 61754-7-1:2014](https://standards.iteh.ai/catalog/standards/sist/5c009097-8e1d-4874-af85-7e2e1421e8/sist-en-61754-7-1-2014)

<https://standards.iteh.ai/catalog/standards/sist/5c009097-8e1d-4874-af85-7e2e1421e8/sist-en-61754-7-1-2014>

Ta slovenski standard je istoveten z: EN 61754-7-1:2014

ICS:

33.180.20	Povezovalne naprave za optična vlakna	Fibre optic interconnecting devices
-----------	---------------------------------------	-------------------------------------

SIST EN 61754-7-1:2014

en

iTeh STANDARD PREVIEW
(standards.iteh.ai)

[SIST EN 61754-7-1:2014](#)

<https://standards.iteh.ai/catalog/standards/sist/5c009097-8e1d-4874-af85-f054674f44e8/sist-en-61754-7-1-2014>

EUROPEAN STANDARD

EN 61754-7-1

NORME EUROPÉENNE

EUROPÄISCHE NORM

October 2014

ICS 33.180.20

Supersedes EN 61754-7:2008 (partially)

English Version

**Fibre optic interconnecting devices and passive components -
Fibre optic connector interfaces - Part 7-1: Type MPO connector
family - One fibre row
(IEC 61754-7-1:2014)**

Dispositifs d'interconnexion et composants passifs à fibres
optiques - Interfaces de connecteurs pour fibres optiques -
Partie 7-1: Famille de connecteurs de type MPO - Une
rangée de fibres
(CEI 61754-7-1:2014)

Lichtwellenleiter - Verbindungselemente und passive
Bauteile - Steckgesichter von Lichtwellenleiter-
Steckverbindern - Teil 7-1: Steckverbinderfamilie der Bauart
MPO - Eine Faserreihe
(IEC 61754-7-1:2014)

This European Standard was approved by CENELEC on 2014-10-08. CENELEC members are bound to comply with the CEN/CENELEC Internal Regulations which stipulate the conditions for giving this European Standard the status of a national standard without any alteration.

Up-to-date lists and bibliographical references concerning such national standards may be obtained on application to the CEN-CENELEC Management Centre or to any CENELEC member.

This European Standard exists in three official versions (English, French, German). A version in any other language made by translation under the responsibility of a CENELEC member into its own language and notified to the CEN-CENELEC Management Centre has the same status as the official versions.

CENELEC members are the national electrotechnical committees of Austria, Belgium, Bulgaria, Croatia, Cyprus, the Czech Republic, Denmark, Estonia, Finland, Former Yugoslav Republic of Macedonia, France, Germany, Greece, Hungary, Iceland, Ireland, Italy, Latvia, Lithuania, Luxembourg, Malta, the Netherlands, Norway, Poland, Portugal, Romania, Slovakia, Slovenia, Spain, Sweden, Switzerland, Turkey and the United Kingdom.



European Committee for Electrotechnical Standardization
Comité Européen de Normalisation Electrotechnique
Europäisches Komitee für Elektrotechnische Normung

CEN-CENELEC Management Centre: Avenue Marnix 17, B-1000 Brussels

Foreword

The text of document 86B/3794A/FDIS, future edition 1 of IEC 61754-7-1, prepared by SC 86B "Fibre optic interconnecting devices and passive components" of IEC/TC 86 "Fibre optics" was submitted to the IEC-CENELEC parallel vote and approved by CENELEC as EN 61754-7-1:2014.

The following dates are fixed:

- latest date by which the document has to be implemented at national level by publication of an identical national standard or by endorsement (dop) 2015-07-08
- latest date by which the national standards conflicting with the document have to be withdrawn (dow) 2017-10-08

This document supersedes EN 61754-7:2008 (Partially).

Attention is drawn to the possibility that some of the elements of this document may be the subject of patent rights. CENELEC [and/or CEN] shall not be held responsible for identifying any or all such patent rights.

Endorsement notice

The text of the International Standard IEC 61754-7-1:2014 was approved by CENELEC as a European Standard without any modification.

(standards.iteh.ai)

[SIST EN 61754-7-1:2014](https://standards.iteh.ai/catalog/standards/sist/5c009097-8e1d-4874-af85-f054674f44e8/sist-en-61754-7-1-2014)

<https://standards.iteh.ai/catalog/standards/sist/5c009097-8e1d-4874-af85-f054674f44e8/sist-en-61754-7-1-2014>



IEC 61754-7-1

Edition 1.0 2014-09

INTERNATIONAL STANDARD

**Fibre optic interconnecting devices and passive components – Fibre optic
connector interfaces –
Part 7-1: Type MPO connector family – One fibre row**

STANDARD PREVIEW
(standards.iteh.ai)
<https://standards.iteh.ai/catalog/standards/sist/5c009097-8e1d-4874-af85-f054674f44e8/sist-en-61754-7-1-2014>

INTERNATIONAL
ELECTROTECHNICAL
COMMISSION

PRICE CODE



ICS 33.180.20

ISBN 978-2-8322-1843-3

Warning! Make sure that you obtained this publication from an authorized distributor.

CONTENTS

FOREWORD	3
1 Scope	5
2 Description	5
3 Interfaces	5
Figure 1 – MPO connector configurations	6
Figure 2 – MPO female plug, down-angled interface	7
Figure 3 – MPO female plug, up-angled interface	7
Figure 4 – Optical datum target location diagrams	9
Figure 5 – Gauge pin	10
Figure 6 – Gauge for plug	10
Figure 7 – MPO male plug, down-angled interface	11
Figure 8 – MPO male plug, up-angled interface	12
Figure 9 – MPO adaptor interface, opposed keyway configuration	14
Figure 10 – MPO female plug, flat interface	16
Figure 11 – MPO male plug, flat interface	18
Figure 12 – MPO backplane housing interface (1 of 2)	20
Figure 13 – MPO printed board housing interface (1 of 2)	23
Figure 14 – MPO adaptor interface, aligned keyway configuration	26
Figure 15 – MPO active device receptacle, angled interface	28
Figure 16 – MPO active device receptacle, flat interface	30
Table 1 – Dimensions of the MPO female plug, down- or up-angled interfaces	8
Table 2 – Dimensions of the gauge pin	10
Table 3 – Dimensions of the gauge for plug	11
Table 4 – Dimensions of the MPO male plug, down- or up-angled interfaces	13
Table 5 – Dimensions of the MPO adaptor interface, opposed keyway configuration	15
Table 6 – Dimensions of the MPO female plug, flat interface	17
Table 7 – Dimensions of the MPO male plug, flat interface	19
Table 8 – Dimensions of the MPO backplane housing	22
Table 9 – Grade	23
Table 10 – Dimensions of the MPO printed board housing interface	25
Table 11 – Dimensions of the MPO adaptor interface, aligned keyway configuration	27
Table 12 – Dimensions of the MPO active device receptacle, angled interface	29
Table 13 – Dimensions of the MPO active device receptacle, flat interface	31

INTERNATIONAL ELECTROTECHNICAL COMMISSION

**FIBRE OPTIC INTERCONNECTING
DEVICES AND PASSIVE COMPONENTS –
FIBRE OPTIC CONNECTOR INTERFACES –**

**Part 7-1: Type MPO connector family –
One fibre row**

FOREWORD

- 1) The International Electrotechnical Commission (IEC) is a worldwide organization for standardization comprising all national electrotechnical committees (IEC National Committees). The object of IEC is to promote international co-operation on all questions concerning standardization in the electrical and electronic fields. To this end and in addition to other activities, IEC publishes International Standards, Technical Specifications, Technical Reports, Publicly Available Specifications (PAS) and Guides (hereafter referred to as "IEC Publication(s)"). Their preparation is entrusted to technical committees; any IEC National Committee interested in the subject dealt with may participate in this preparatory work. International, governmental and non-governmental organizations liaising with the IEC also participate in this preparation. IEC collaborates closely with the International Organization for Standardization (ISO) in accordance with conditions determined by agreement between the two organizations.
- 2) The formal decisions or agreements of IEC on technical matters express, as nearly as possible, an international consensus of opinion on the relevant subjects since each technical committee has representation from all interested IEC National Committees.
- 3) IEC Publications have the form of recommendations for international use and are accepted by IEC National Committees in that sense. While all reasonable efforts are made to ensure that the technical content of IEC Publications is accurate, IEC cannot be held responsible for the way in which they are used or for any misinterpretation by any end user.
- 4) In order to promote international uniformity, IEC's National Committees undertake to apply IEC Publications transparently to the maximum extent possible in their national and regional publications. Any divergence between any IEC Publication and the corresponding national or regional publication shall be clearly indicated in the latter.
- 5) IEC itself does not provide any attestation of conformity. Independent certification bodies provide conformity assessment services and, in some areas, access to IEC marks of conformity. IEC is not responsible for any services carried out by independent certification bodies.
- 6) All users should ensure that they have the latest edition of this publication.
- 7) No liability shall attach to IEC or its directors, employees, servants or agents including individual experts and members of its technical committees and IEC National Committees for any personal injury, property damage or other damage of any nature whatsoever, whether direct or indirect, or for costs (including legal fees) and expenses arising out of the publication, use of, or reliance upon, this IEC Publication or any other IEC Publications.
- 8) Attention is drawn to the Normative references cited in this publication. Use of the referenced publications is indispensable for the correct application of this publication.
- 9) Attention is drawn to the possibility that some of the elements of this IEC Publication may be the subject of patent rights. IEC shall not be held responsible for identifying any or all such patent rights.

International Standard IEC 61754-7-1 has been prepared by subcommittee 86B: Fibre optic interconnecting devices and passive components, of IEC technical committee 86: Fibre optics.

This first edition of IEC 61754-7-1, along with the first edition of IEC 61754-7-2, cancels and replaces the third edition of IEC 61754-7, published in 2008.

This first edition of IEC 61754-7-1 includes the one fibre row MPO variants, including the addition of active device receptacles and up-angled plugs.

The first edition of IEC 61754-7-2 will include the two fibre row MPO variants and related active device receptacles and up-angled plugs.

Following the publication of both IEC 61754-7-1 and IEC 61754-7-2, IEC 61754-7 will be withdrawn.

The text of this standard is based on the following documents:

FDIS	Report on voting
86B/3794A/FDIS	86B/3826/RVD

Full information on the voting for the approval of this standard can be found in the report on voting indicated in the above table.

This publication has been drafted in accordance with the ISO/IEC Directives, Part 2.

A list of all the parts in the IEC 61754 series, under the general title *Fibre optic interconnecting devices and passive components – fibre optic connector interfaces*, can be found on the IEC website.

The committee has decided that the contents of this publication will remain unchanged until the stability date indicated on the IEC web site under "<http://webstore.iec.ch>" in the data related to the specific publication. At this date, the publication will be

- reconfirmed,
- withdrawn,
- replaced by a revised edition, or
- amended.

ITeH STANDARD PREVIEW
(standards.iteh.ai)

A bilingual version of this publication may be issued at a later date.

[SIST EN 61754-7-1:2014](#)

<https://standards.iteh.ai/catalog/standards/sist/5c009097-8e1d-4874-af85-f054674f44e8/sist-en-61754-7-1-2014>

FIBRE OPTIC INTERCONNECTING DEVICES AND PASSIVE COMPONENTS – FIBRE OPTIC CONNECTOR INTERFACES –

Part 7-1: Type MPO connector family – One fibre row

1 Scope

This part of IEC 61754 defines the standard interface dimensions for type MPO family of connectors with one row of fibres.

2 Description

The parent connector for type MPO connector family is a multiway plug characterized by a rectangular ferrule normally 6,4 mm × 2,5 mm which utilizes two pins of 0,7 mm diameter as its alignment. The variant in this standard provides a joint of 2 to 12 fibres by arraying them between two pin-positioning holes in the ferrule in a one-layer, (one-row) arrangement. The connector includes a push-pull coupling mechanism and a ferrule spring loaded in the direction of the optical axis. The connector has a single male key which may be used to orient and limit the relative position between the connector and the component to which it is mated.

Connector interfaces are configured using a female plug without pins, a male plug with pins fixed and an adaptor as shown in Figure 1. The female plug is interchangeable with the male plug.

There are two angled-interface plugs, one called down-angled and the other up-angled. They are defined for both male and female plugs. The up and down descriptors refer to the tilt direction of the ferrule's angled end-face relative to the fibre axis when looking toward the end-face with the plug's key feature on the top. For down-angled plugs, the angled surface faces slightly downward. For up-angled plugs, the angled surface faces slightly upward. These different angles affect interchangeability for the two adaptor types. An opposed keyway adaptor mates two plugs with the keys in opposite orientations, for example one side keyway-up and the other keyway-down. In contrast, an aligned keyway adaptor mates two plugs with the keys at the same orientation. When using an opposed keyway adaptor with angled interfaces, two down-angled plugs or two up-angled plugs are connected. For aligned keyway adaptors with angled interfaces, one down-angled plug and one up-angled plug are connected.

Moreover, connector interfaces between the female plug and the male plug are configured by applying a backplane housing and a printed board housing instead of the adaptor.

Additionally, the female plug interface is interchangeable with the active device receptacle.

3 Interfaces

This standard contains the following standard interfaces:

- Interface IEC 61754-7-1-1: MPO female plug, down-angled interface for 2 to 12 fibres
- Interface IEC 61754-7-1-2: MPO male plug, down-angled interface for 2 to 12 fibres
- Interface IEC 61754-7-1-3: MPO adaptor interface – Opposed keyway configuration
- Interface IEC 61754-7-1-4: MPO female plug, flat interface for 2 to 12 fibres

- Interface IEC 61754-7-1-5: MPO male plug, flat interface for 2 to 12 fibres
 Interface IEC 61754-7-1-6: MPO backplane housing interface
 Interface IEC 61754-7-1-7: MPO printed board housing interface
 Interface IEC 61754-7-1-8: MPO adaptor interface – Aligned keyway configuration
 Interface IEC 61754-7-1-9: MPO active device receptacle, angled interface
 Interface IEC 61754-7-1-10: MPO active device receptacle, flat interface
 Interface IEC 61754-7-1-11: MPO female plug, up-angled interface for 2 to 12 fibres
 Interface IEC 61754-7-1-12: MPO male plug, up-angled interface for 2 to 12 fibres

The following interfaces are intermateable:

Female plugs	Adaptors/housings/receptacles	Male plugs
61754-7-1-1	61754-7-1-3	61754-7-1-2
61754-7-1-11	61754-7-1-3	61754-7-1-12
61754-7-1-1	61754-7-1-8	61754-7-1-12
61754-7-1-11	61754-7-1-8	61754-7-1-2
61754-7-1-4	61754-7-1-3 and 61754-7-1-8	61754-7-1-5
61754-7-1-1 or 61754-7-1-11	61754-7-1-6 and 61754-7-1-7	61754-7-1-2 or 61754-7-1-12
61754-7-1-4	61754-7-1-6 and 7-1-7	61754-7-1-5
61754-7-1-1	61754-7-1-9	N/A
61754-7-1-4	61754-7-1-10	N/A

NOTE Connector interfaces with 2 to 12 fibres will intermate and will correctly align the lower defined numbers of optical datum targets (see Figure 4)

Figure 1 shows MPO connector configurations.

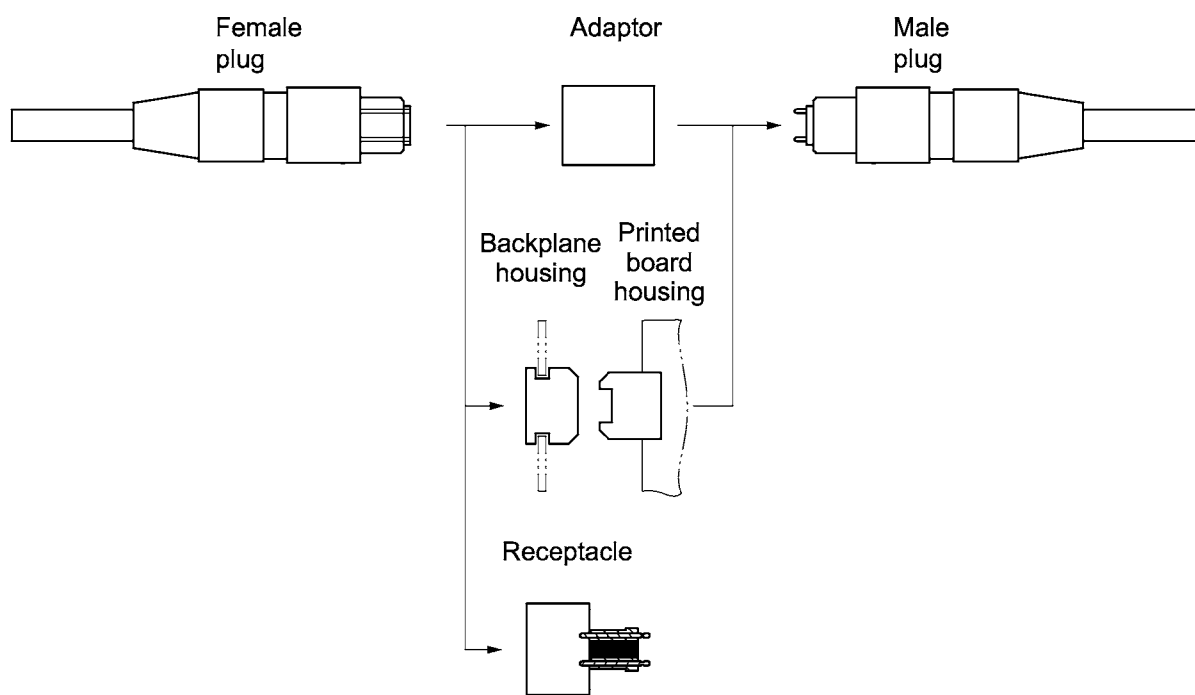

IEC

Figure 1 – MPO connector configurations

Figures 2 and 3 show down-angled and up-angled interface of the MPO female plug. Table 1 gives the dimensions of the MPO female plug, down- or up-angled interfaces.

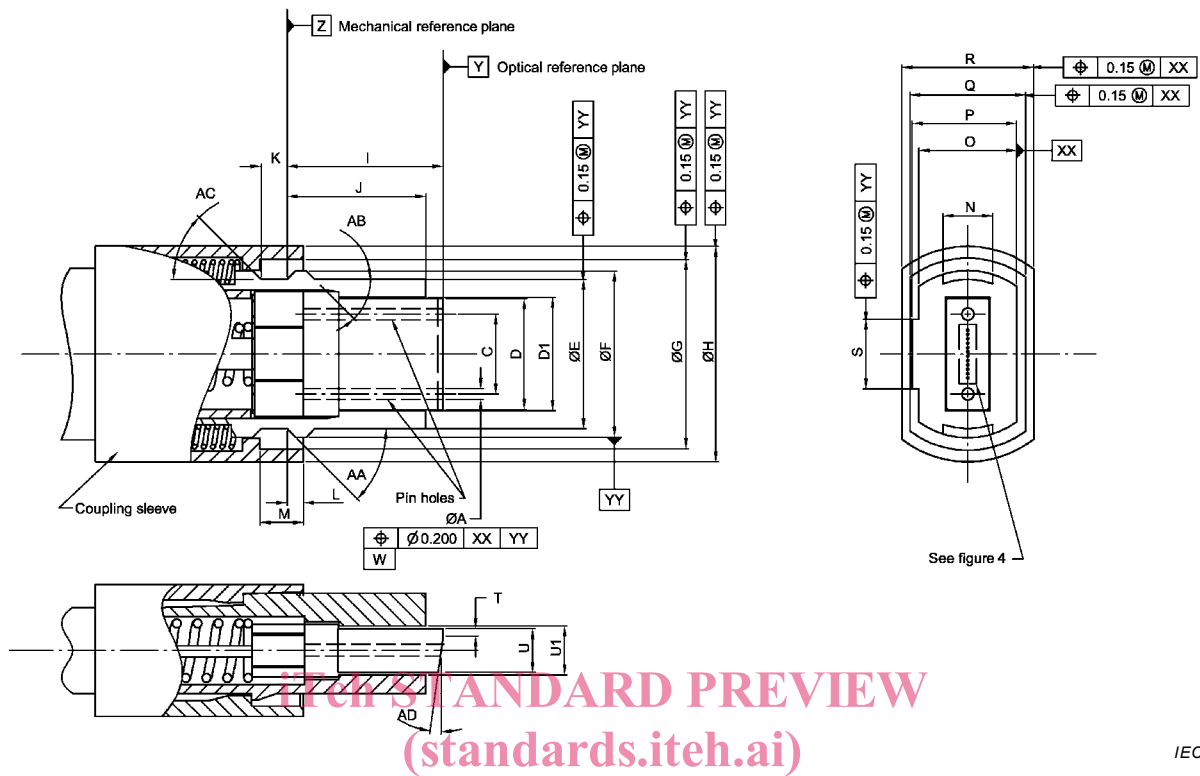

Figure 2 – MPO female plug, down-angled interface

<https://standards.iteh.ai/catalog/standards/sist/5c009097-8e1d-4874-af85-f054674f14e8/sist-en-61754-7-1-2014>

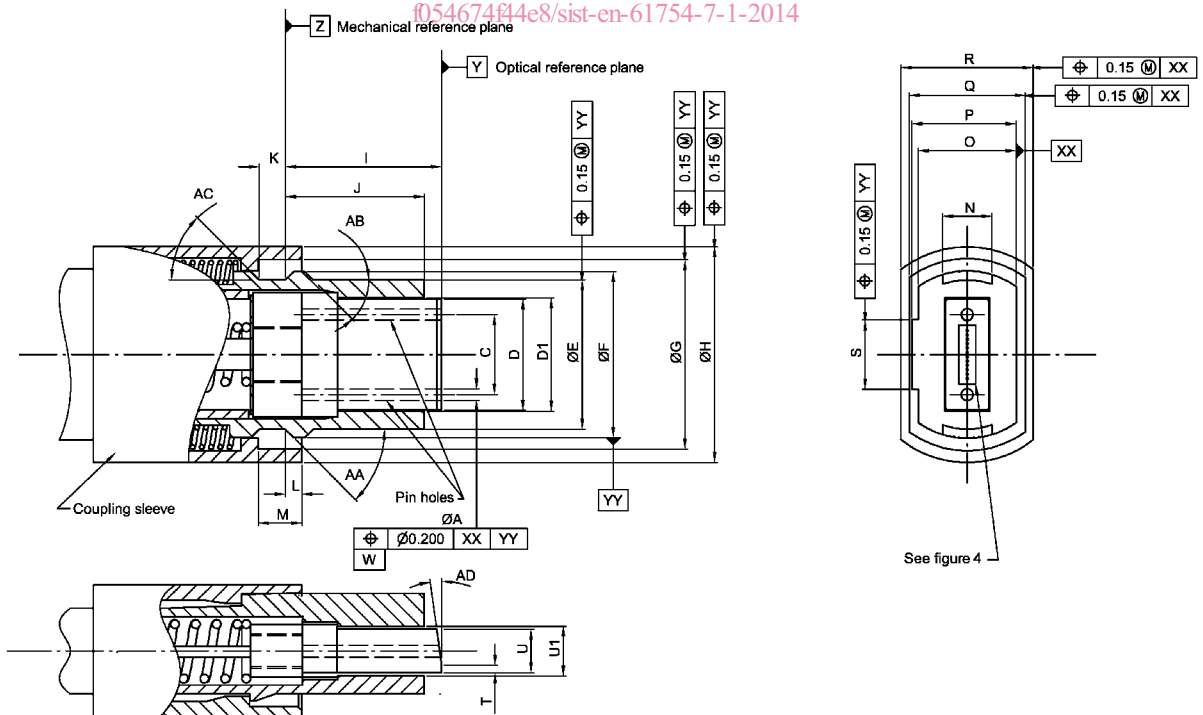

Figure 3 – MPO female plug, up-angled interface

Table 1 – Dimensions of the MPO female plug, down- or up-angled interfaces

Reference	Dimensions	
	Minimum	Maximum
A ^a	0,699 mm	0,701 mm
C ^b	4,597 mm	4,603 mm
D	6,3 mm	6,5 mm
D1 ^h	6,7 mm	–
E	8,34 mm	8,54 mm
F	9,49 mm	9,59 mm
G	10,85 mm	11,05 mm
H	12,19 mm	12,59 mm
I ^{c,f}	8,8 mm	9,2 mm
J	7,9 mm	8,1 mm
K	1,4 mm	–
L ^{d,e}	0,2 mm	0,8 mm
M	2,4 mm	2,6 mm
N	2,8 mm	3,0 mm
O	4,89 mm	4,99 mm
P	5,59 mm	5,69 mm
Q	5,7 mm	–
R	–	7,7 mm
S	2,9 mm	3,1 mm
T	–	0,8 mm
U	2,4 mm	2,5 mm
U1 ^h	2,7 mm	–
AA	42°	45°
AB	–	45°
AC	–	45°
AD ^{i,j}	7,5°	8,5°

^a Each pin-hole shall accept a gauge pin as shown in Figure 5 to a depth of 5,5 mm with a maximum force of 1,7 N. In addition, two pin-holes of a plug shall accept a gauge as shown in Figure 5 to a depth of 5,5 mm with a maximum force of 3,4 N.

^b Dimension C is defined as the distance between two pin-hole centres.

^c Dimension I is given for a fibre endface centre of a plug end when not mated. It is noticed that a ferrule is movable by a certain axial compression force, and therefore dimension I is variable. Ferrule compression force shall be 7,8 N to 11,8 N when a position of the fibre endface from the datum Z is in the range of 8,2 mm to 8,4 mm.

^d The coupling sleeve shall be movable by a certain axial compression force. Dimension L is given for a coupling sleeve end when not mated. Coupling sleeve compression force shall be 2,9 N to 6,9 N when the position of the coupling sleeve endface from datum Z is in the range of 0 mm to 0,1 mm to the right or to the left of datum Z.

^e An adaptor coupling part shall be unlocked by a left-direction movement of a coupling sleeve, when it is separate from an adaptor. When the coupling sleeve is moved for unlocking, the position of the coupling sleeve endface shall be larger than 2,0 mm in the left direction from the datum Z.

^f Dimension I is defined at the centre line between the two pin-hole centres.

^g The mating/unmating force between an MPO plug and adaptor shall not exceed 30,0 N.

^h Dimensions D1 and U1 are defined only at the end of the plug as shown.

ⁱ The down-angled and up-angled plugs shall be clearly marked to distinguish them from each other and flat interfaces through the use of colour, labelling or other appropriate identification method. This identification method shall be visible when the plug is in the mated or unmated condition.

^j Since angled MPO plugs require a Y-offset of the fibre holes in relation to the guide pin holes, and the Y-offset is referenced from the epoxy window of the ferrule, the angle shall be polished as a down-angle from the epoxy window. The orientation of the ferrule epoxy window may be reversed in the MPO plug to produce the up-angle variant.

Figure 4 shows optical datum target location diagrams. Figure 5 shows the gauge pin and Table 2 shows its dimensions.