

**SLOVENSKI STANDARD**  
**SIST ISO 9462:1995/Amd 1:2003**  
**01-julij-2003**

---

JUfbcgfbYj Ynj'nUUdg\_Y'ga i ]!'JUfbcgfbY'nU hYj Y]b'dfYg\_i gbY'a YrcXY

Alpine ski-bindings -- Safety requirements and test methods

Fixations de skis alpins -- Prescriptions de sécurité et méthodes d'essai

**Ta slovenski standard je istoveten z: ISO 9462:1993/Amd 1:2002**

[SIST ISO 9462:1995/Amd 1:2003](https://standards.iteh.ai/catalog/standards/sist/44e46270-6e6f-48c1-87ea-e069bdfbd4bc/sist-iso-9462-1995-amd-1-2003)

<https://standards.iteh.ai/catalog/standards/sist/44e46270-6e6f-48c1-87ea-e069bdfbd4bc/sist-iso-9462-1995-amd-1-2003>

**ICS:**

97.220.20      Oprema za zimske športe      Winter sports equipment

**SIST ISO 9462:1995/Amd 1:2003**      en

**iTeh STANDARD PREVIEW**  
**(standards.iteh.ai)**

[SIST ISO 9462:1995/Amd 1:2003](https://standards.iteh.ai/catalog/standards/sist/44e46270-6e6f-48c1-87ea-e069bdfbd4bc/sist-iso-9462-1995-amd-1-2003)

<https://standards.iteh.ai/catalog/standards/sist/44e46270-6e6f-48c1-87ea-e069bdfbd4bc/sist-iso-9462-1995-amd-1-2003>

# INTERNATIONAL STANDARD

**ISO**  
**9462**

Second edition  
1993-05-15

**AMENDMENT 1**  
2002-06-01

---

---

## Alpine ski-bindings — Safety requirements and test methods

### AMENDMENT 1

*Fixations de skis alpins — Prescriptions de sécurité et méthodes d'essai —*

**iTeh STANDARD PREVIEW**  
**(standards.iteh.ai)**

SIST ISO 9462:1995/Amd 1:2003

<https://standards.iteh.ai/catalog/standards/sist/44e46270-6e6f-48c1-87ea-e069bdfbd4bc/sist-iso-9462-1995-amd-1-2003>



Reference number  
ISO 9462:1993/Amd.1:2002(E)

© ISO 2002

## ISO 9462:1993/Amd.1:2002(E)

**PDF disclaimer**

This PDF file may contain embedded typefaces. In accordance with Adobe's licensing policy, this file may be printed or viewed but shall not be edited unless the typefaces which are embedded are licensed to and installed on the computer performing the editing. In downloading this file, parties accept therein the responsibility of not infringing Adobe's licensing policy. The ISO Central Secretariat accepts no liability in this area.

Adobe is a trademark of Adobe Systems Incorporated.

Details of the software products used to create this PDF file can be found in the General Info relative to the file; the PDF-creation parameters were optimized for printing. Every care has been taken to ensure that the file is suitable for use by ISO member bodies. In the unlikely event that a problem relating to it is found, please inform the Central Secretariat at the address given below.

## iTeh STANDARD PREVIEW (standards.iteh.ai)

[SIST ISO 9462:1995/Amd 1:2003](https://standards.iteh.ai/catalog/standards/sist/44e46270-6e6f-48c1-87ea-e069bdfbd4bc/sist-iso-9462-1995-amd-1-2003)

<https://standards.iteh.ai/catalog/standards/sist/44e46270-6e6f-48c1-87ea-e069bdfbd4bc/sist-iso-9462-1995-amd-1-2003>

© ISO 2002

All rights reserved. Unless otherwise specified, no part of this publication may be reproduced or utilized in any form or by any means, electronic or mechanical, including photocopying and microfilm, without permission in writing from either ISO at the address below or ISO's member body in the country of the requester.

ISO copyright office  
Case postale 56 • CH-1211 Geneva 20  
Tel. + 41 22 749 01 11  
Fax + 41 22 749 09 47  
E-mail [copyright@iso.ch](mailto:copyright@iso.ch)  
Web [www.iso.ch](http://www.iso.ch)

Printed in Switzerland

## Foreword

ISO (the International Organization for Standardization) is a worldwide federation of national standards bodies (ISO member bodies). The work of preparing International Standards is normally carried out through ISO technical committees. Each member body interested in a subject for which a technical committee has been established has the right to be represented on that committee. International organizations, governmental and non-governmental, in liaison with ISO, also take part in the work. ISO collaborates closely with the International Electrotechnical Commission (IEC) on all matters of electrotechnical standardization.

International Standards are drafted in accordance with the rules given in the ISO/IEC Directives, Part 3.

The main task of technical committees is to prepare International Standards. Draft International Standards adopted by the technical committees are circulated to the member bodies for voting. Publication as an International Standard requires approval by at least 75 % of the member bodies casting a vote.

Attention is drawn to the possibility that some of the elements of this Amendment may be the subject of patent rights. ISO shall not be held responsible for identifying any or all such patent rights.

Amendment 1 to International Standard ISO 9462:1993 was prepared by Technical Committee ISO/TC 83, *Sports and recreational equipment*, Subcommittee SC 3, *Ski bindings*.

**iTeh STANDARD PREVIEW**  
**(standards.iteh.ai)**

[SIST ISO 9462:1995/Amd 1:2003](https://standards.iteh.ai/catalog/standards/sist/44e46270-6e6f-48c1-87ea-e069bdfbd4bc/sist-iso-9462-1995-amd-1-2003)

<https://standards.iteh.ai/catalog/standards/sist/44e46270-6e6f-48c1-87ea-e069bdfbd4bc/sist-iso-9462-1995-amd-1-2003>

**ISO 9462:1993/Amd.1:2002(E)****Introduction**

This Amendment to ISO 9462:1993 specifies the following characteristics of ski-bindings:

- behaviour under combined loading;
- behaviour with ski deflection.

ISO 9462:1993 is limited to the so-called first category tests, for which the use of methods A and B lead, in principle, to equivalent results. This concerns tests in simple torsion and in simple forward bending.

Two important characteristics of a ski-binding, i.e. its behaviour under combined loading and its behaviour with ski deflection, remain unchecked in ISO 9462:1993.

Several attempts were made to find test procedures leading to equivalent results using methods A and B. Each of these attempts was followed by comparative test series involving most of the existing laboratories working in this field.

The poor reproducibility observed between the laboratories has led to the opinion that when combined loading are involved with or without deflection of the ski, the equivalence of the results using methods A and B was extremely difficult to achieve at a reasonable cost.

Therefore it was decided to define the tests and requirements with combined loading and deflection of the ski separately for both methods. For method A, the tests and requirements described in this Amendment are identical to those described in DIN 7881-1:1982 and BfU-requirements (Swiss office of accident prevention) of 1984-06.

<https://standards.iteh.ai/catalog/standards/sist/44e46270-6e6f-48c1-87ea-e069bdfbd4bc/sist-iso-9462-1995-amd-1-2003>

# Alpine ski-bindings — Safety requirements and test methods

## AMENDMENT 1

Page 1: replace Figure 1 and its title by the following new Figure 1 and title.

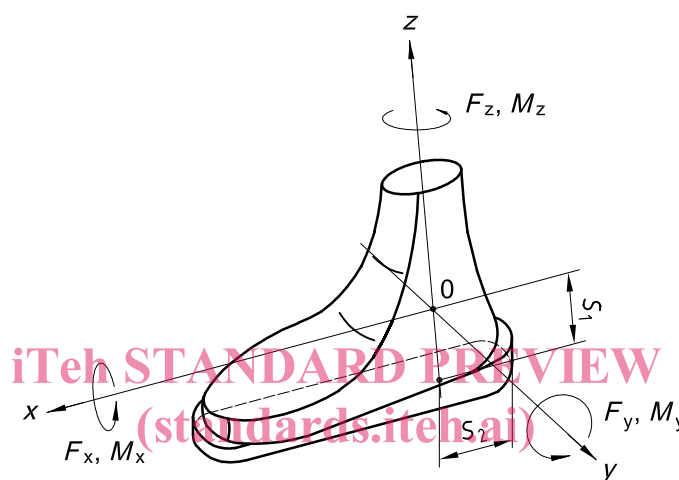

SIST ISO 9462:1995/Amd 1:2003  
<https://standards.iteh.ai/en/standards/ISO-9462-1995/Amd-1-2003/87eae069bdfbd4bc/sist-iso-9462-1995-amd-1-2003>  
**Figure 1 — Definition of loads and torques**

Pages 3 and 7: renumber the previous Tables 1 and 2 as 2 and 3 respectively.

Page 2: renumber the previous subclauses 3.5 to 3.11 as 3.8 to 3.14 in succession.

Page 2: add the following new elements.

### 3.5 Combined loading

Loading of the sole in several directions at the same time, where one of the loads is the torque  $M_z$  progressively applied to the sole until the binding releases, see Figure 1 and Table 1.

**Table 1 — Coordinates of reference point O**

Dimensions in millimetres

|       | Type of binding |     |     |
|-------|-----------------|-----|-----|
|       | C               | CA  | A   |
| $S_1$ | 85              | 100 | 100 |
| $S_2$ | 70              | 80  | 80  |

**ISO 9462:1993/Amd.1:2002(E)**

Each of the load combinations simulates a given situation, chosen within an infinite field of possibilities and simplified for the purpose of the tests. The main simplification is that the loads applied additionally to the release torque  $M_z$  are held constant in value and direction during all the release process.

**3.6 Additional loads**

Loads applied additionally to the release torque  $M_z$ .

**3.7 Deflection of ski**

Deflection of the ski perpendicular to its gliding surface. In practice, the deflection of the ski depends at the same time on the loading situation and the profile of the snow-surface ("geometrical situation"). To simplify the test, only the "geometrical" situation is simulated.

Page 8

Renumber the previous subclauses 6.3.2 to 6.3.5 as 6.3.4 to 6.3.7 in succession.

As a result, renumber subclauses in the previous subclauses 6.3.2 to 6.3.5.

Add the following new text.

**6.3.2 Release with ski deflection**

**STANDARD PREVIEW**  
(standards.iteh.ai)

**6.3.2.1 Requirements**

The mean value of the deviations between each of the release values and the corresponding reference value shall not exceed 20 % for the torsion release ( $M_z$ ) and 15 % for the forward bending release ( $M_y$ ).

None of the five values for the torsion release shall exceed  $\pm 10$  % of their mean value.

None of the five release values for the forward bending release shall exceed  $\pm 7,5$  % of their mean value.

**6.3.2.2 Testing**

Subject only one binding to the test. Release the binding five times in torsion to the right and five times in forward bending. Carry out the tests at ambient temperature ( $23 \text{ °C} \pm 5 \text{ °C}$ ) with wet sole and binding.

Position and deflect the test ski with the sole inserted in the binding in accordance with Figure 6 and Table 4, and force the ski to deflect to given values by a strap or clamp, which does not interfere with the binding. If the distance between the supports is different, ensure that the same deflection of the ski used.

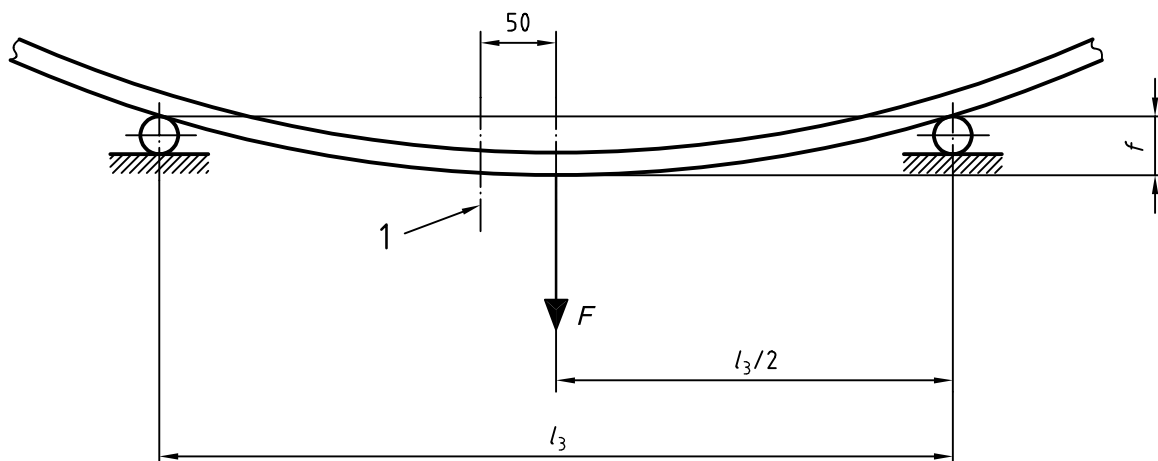

Dimensions in millimetres

**Key**

1 Boot toe

**Figure 6 — Deflection of ski****Table 4 — Deflection of ski according to type of binding**

Dimensions in millimetres

|       | Type of binding |            |
|-------|-----------------|------------|
|       | C, CA           | A          |
| $f$   | $20 \pm 1$      | $60 \pm 1$ |
| $l_3$ | 1 100           | 1 500      |

**6.3.3 Release under combined loading****6.3.3.1 General requirements about scattering**

For a given test, each of the five release values shall remain within  $\pm 10\%$  of their mean value.

**6.3.3.2 General test conditions**

Subject only one binding to the following tests. Carry out these tests at ambient temperature ( $23\text{ °C} \pm 5\text{ °C}$ ), with wet sole and binding.

For each of the following configurations of combined loading, release the binding five times in torsion to the right.

The values of the additional load are proportional to the reference value  $M_z$  measured according to 6.3.1.

Apply the combined loads to the ski-boot during all its movements, which shall remain constant in amplitude and in direction relative to the ski-boot.