

# INTERNATIONAL STANDARD

# ISO 14508

First edition  
1997-07-15

---

---

## Road vehicles — Spark-plugs — Terminals

*Véhicules routiers — Bougies d'allumage — Bornes*

**iTeh STANDARD PREVIEW**  
**(standards.iteh.ai)**

ISO 14508:1997

<https://standards.iteh.ai/catalog/standards/sist/b1637a86-e808-455f-a804-efc81b871066/iso-14508-1997>



Reference number  
ISO 14508:1997(E)

## Foreword

ISO (the International Organization for Standardization) is a worldwide federation of national standards bodies (ISO member bodies). The work of preparing International Standards is normally carried out through ISO technical committees. Each member body interested in a subject for which a technical committee has been established has the right to be represented on that committee. International organizations, governmental and non-governmental, in liaison with ISO, also take part in the work. ISO collaborates closely with the International Electrotechnical Commission (IEC) on all matters of electrotechnical standardization.

Draft International Standards adopted by the technical committees are circulated to the member bodies for voting. Publication as an International Standard requires approval by at least 75 % of the member bodies casting a vote.

International Standard ISO 14508 was prepared by Technical Committee ISO/TC 22, *Road vehicles*, Subcommittee SC 1, *Ignition equipment*.

Annex A of this International Standard is for information only.

*iTeh STANDARD PREVIEW*  
*(Standards.iteh.ai)*  
ISO 14508:1997  
<https://standards.iteh.ai/catalog/standards/sist/b1637a86-e808-455f-a804-efc81b871066/iso-14508-1997>

© ISO 1997

All rights reserved. Unless otherwise specified, no part of this publication may be reproduced or utilized in any form or by any means, electronic or mechanical, including photocopying and microfilm, without permission in writing from the publisher.

International Organization for Standardization  
Case postale 56 • CH-1211 Genève 20 • Switzerland  
Internet central@iso.ch  
X.400 c=ch; a=400net; p=iso; o=isocs; s=central

Printed in Switzerland

# Road vehicles — Spark-plugs — Terminals

## 1 Scope

This International Standard specifies the dimensions of the solid post terminals and threaded terminals for spark-plugs.

## 2 Normative references

The following standards contain provisions which, through reference in this text, constitute provisions of this International Standard. At the time of publication, the editions indicated were valid. All standards are subject to revision, and parties to agreements based on this International Standard are encouraged to investigate the possibility of applying the most recent editions of the standards listed below. Members of IEC and ISO maintain registers of currently valid International Standards.

ISO 68:1973, *ISO general purpose screw threads — Basic profile.*

ISO 14508:1997

ISO 261:1973, *ISO general purpose metric screw threads — General plan.*

http://standards.iteh.ai/standards/iso-14508-1997

## 3 Solid post terminal dimensions

Solid post terminals shall conform to the dimensions given in figure 1.

Dimensions in millimetres

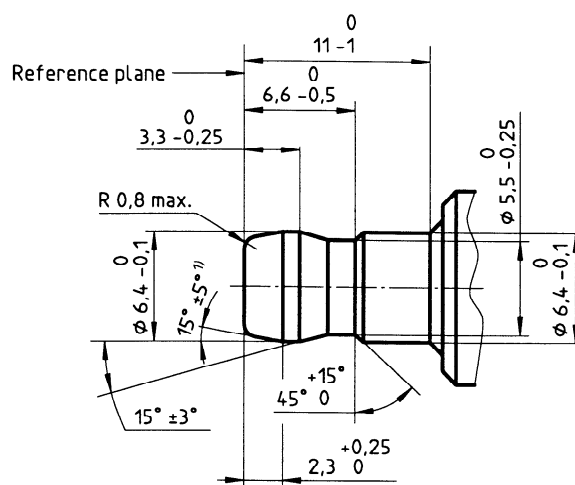

1) For existing products, values between 7° and 30° are allowed.

Figure 1 — Solid post terminal

Nuts for use with threaded terminals shall have the same external dimensions as those of the solid post terminal, and shall have internal threads to 6H tolerance prior to assembly on the threaded terminals.

The measurement of the minimum diameter of 6,3 mm shall be taken at any or all points around the post circumference. A ring gauge shall be used for measuring the maximum diameter of 6,4 mm.

#### 4 Threaded terminal dimensions

Threaded terminals shall conform to the dimensions given in figure 2.

Dimensions in millimetres

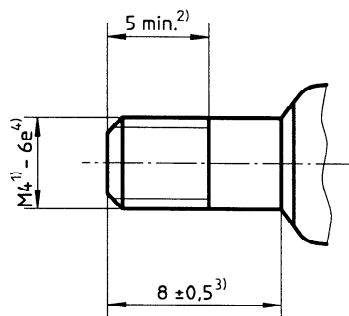

- 1) 0,7 mm pitch complying with ISO 68 and with ISO 261.
- 2) Length of usable thread.
- 3) Cylindrical part.
- 4) Depending on manufacturing processes, class 7e is acceptable on the finished product.

ISO 14508:1997  
**Figure 2 — Threaded terminal**  
<https://standards.iso.org/standards/catalog/standards/siv/61097/86-e808-455f-a804-efc81b871066/iso-14508-1997>

## Annex A (informative)

### Bibliography

- [1] ISO 1919:—<sup>1)</sup>, *Road vehicles — M14 × 1,25 spark-plugs with flat seating and their cylinder head housings.*
- [2] ISO 2344:—<sup>2)</sup>, *Road vehicles — M14 × 1,25 spark-plugs with conical seating and their cylinder head housings.*
- [3] ISO 2345:1994, *Road vehicles — M18 × 1,5 spark-plugs with conical seating and their cylinder head housing.*
- [4] ISO 2346:1991, *Road vehicles — M14 × 1,25 compact spark-plugs with flat seating and their cylinder head housing.*
- [5] ISO 2347:1994, *Road vehicles — M14 × 1,25 compact spark-plugs with conical seating and their cylinder head housing.*
- [6] ISO 2704:—<sup>3)</sup>, *Road vehicles — M10 × 1 spark-plugs with flat seating and their cylinder head housings.*
- [7] ISO 2705:1991, *Road vehicles — M12 × 1,25 spark-plugs with flat seating and their cylinder head housing.*
- [8] ISO 8470:1990, *Road vehicles — M14 × 1,25 spark-plugs with flat seating and 16 mm hexagon and their cylinder head housing.*

**(standards.iteh.ai)**

ISO 14508:1997

<https://standards.iteh.ai/catalog/standards/sist/b1637a86-e808-455f-a804-efc81b871066/iso-14508-1997>

---

1) To be published. (Revision of ISO 1919:1988)

2) To be published. (Revision of ISO 2344:1992)

3) To be published. (Revision of ISO 2704:1993)

**iTeh STANDARD PREVIEW**  
This page intentionally left blank  
**(standards.iteh.ai)**

ISO 14508:1997

<https://standards.iteh.ai/catalog/standards/sist/b1637a86-e808-455f-a804-efc81b871066/iso-14508-1997>

**iTeh STANDARD PREVIEW**  
This page intentionally left blank  
**(standards.iteh.ai)**

ISO 14508:1997

<https://standards.iteh.ai/catalog/standards/sist/b1637a86-e808-455f-a804-efc81b871066/iso-14508-1997>

**iTeh STANDARD PREVIEW**  
**(standards.iteh.ai)**

ISO 14508:1997

<https://standards.iteh.ai/catalog/standards/sist/b1637a86-e808-455f-a804-efc81b871066/iso-14508-1997>

---

---

**ICS 43.060.50**

**Descriptors:** road vehicles, motor vehicles, internal combustion engines, ignition systems (engines), spark plugs, electric terminals, dimensions.

Price based on 3 pages

---

---