**Road vehicles — Component test methods
for electrical disturbances from narrowband
radiated electromagnetic energy —**

**Part 5:
Stripline**

iTeh STANDARD PREVIEW

*Véhicules routiers — Méthodes d'essai d'un équipement soumis à des
perturbations électriques par rayonnement d'énergie électromagnétique en
bande étroite —*

ISO 11452-5:2002
Partie 5: Ligne TEM à plaques

<https://standards.iteh.ai/catalog/standards/sist/1970df7a-34fb-42aa-88f0-c062dbf32c6/iso-11452-5-2002>



PDF disclaimer

This PDF file may contain embedded typefaces. In accordance with Adobe's licensing policy, this file may be printed or viewed but shall not be edited unless the typefaces which are embedded are licensed to and installed on the computer performing the editing. In downloading this file, parties accept therein the responsibility of not infringing Adobe's licensing policy. The ISO Central Secretariat accepts no liability in this area.

Adobe is a trademark of Adobe Systems Incorporated.

Details of the software products used to create this PDF file can be found in the General Info relative to the file; the PDF-creation parameters were optimized for printing. Every care has been taken to ensure that the file is suitable for use by ISO member bodies. In the unlikely event that a problem relating to it is found, please inform the Central Secretariat at the address given below.

iTeh STANDARD PREVIEW
(standards.iteh.ai)

[ISO 11452-5:2002](https://standards.iteh.ai/catalog/standards/sist/1970df7a-34fb-42aa-88f0-c062dbf32c6/iso-11452-5-2002)

<https://standards.iteh.ai/catalog/standards/sist/1970df7a-34fb-42aa-88f0-c062dbf32c6/iso-11452-5-2002>

© ISO 2002

All rights reserved. Unless otherwise specified, no part of this publication may be reproduced or utilized in any form or by any means, electronic or mechanical, including photocopying and microfilm, without permission in writing from either ISO at the address below or ISO's member body in the country of the requester.

ISO copyright office
Case postale 56 • CH-1211 Geneva 20
Tel. + 41 22 749 01 11
Fax + 41 22 749 09 47
E-mail copyright@iso.ch
Web www.iso.ch

Printed in Switzerland

Contents

	Page
1 Scope	1
2 Normative reference	1
3 Terms and definitions	1
4 Test conditions	1
5 Test apparatus	2
6 Test procedure	4

Annexes

A Stripline design	6
B Function performance status classification (FPSC)	11
C Artificial network (AN) schematic	12

iTeh STANDARD PREVIEW
(standards.iteh.ai)

[ISO 11452-5:2002](https://standards.iteh.ai/catalog/standards/sist/1970df7a-34fb-42aa-88f0-c062dbf32c6/iso-11452-5-2002)

<https://standards.iteh.ai/catalog/standards/sist/1970df7a-34fb-42aa-88f0-c062dbf32c6/iso-11452-5-2002>

Foreword

ISO (the International Organization for Standardization) is a worldwide federation of national standards bodies (ISO member bodies). The work of preparing International Standards is normally carried out through ISO technical committees. Each member body interested in a subject for which a technical committee has been established has the right to be represented on that committee. International organizations, governmental and non-governmental, in liaison with ISO, also take part in the work. ISO collaborates closely with the International Electrotechnical Commission (IEC) on all matters of electrotechnical standardization.

International Standards are drafted in accordance with the rules given in the ISO/IEC Directives, Part 3.

Draft International Standards adopted by the technical committees are circulated to the member bodies for voting. Publication as an International Standard requires approval by at least 75 % of the member bodies casting a vote.

Attention is drawn to the possibility that some of the elements of this part of ISO 11452 may be the subject of patent rights. ISO shall not be held responsible for identifying any or all such patent rights.

International Standard ISO 11452-5 was prepared by Technical Committee ISO/TC 22, *Road vehicles*, Subcommittee SC 3, *Electrical and electronic equipment*.

This second edition cancels and replaces the first edition (ISO 11452-5:1995), which has been technically revised.

ISO 11452 consists of the following parts, under the general title *Road vehicles — Component test methods for electrical disturbances from narrowband radiated electromagnetic energy*:

- Part 1: *General and definitions*
- Part 2: *Absorber-lined shielded enclosure*
- Part 3: *Transverse electromagnetic mode (TEM) cell*
- Part 4: *Bulk current injection (BCI)*
- Part 5: *Stripline*
- Part 6: *Parallel plate antenna*
- Part 7: *Direct radio frequency (RF) power injection*

Annexes A, B and C of this part of ISO 11452 are for information only.

Introduction

Immunity measurements of complete road vehicles are generally able to be carried out only by the vehicle manufacturer, owing to, for example, high costs of absorber-lined shielded enclosures, the desire to preserve the secrecy of prototypes or a large number of different vehicle models.

For research, development and quality control, a laboratory measuring method can be used by both vehicle manufacturers and equipment suppliers to test electronic components.

iTeh STANDARD PREVIEW (standards.iteh.ai)

[ISO 11452-5:2002](https://standards.iteh.ai/catalog/standards/sist/1970df7a-34fb-42aa-88f0-c062dbf32c6/iso-11452-5-2002)

<https://standards.iteh.ai/catalog/standards/sist/1970df7a-34fb-42aa-88f0-c062dbf32c6/iso-11452-5-2002>

iTeh STANDARD PREVIEW
(standards.iteh.ai)

[ISO 11452-5:2002](https://standards.iteh.ai/catalog/standards/sist/1970df7a-34fb-42aa-88f0-c062dbf32c6/iso-11452-5-2002)

<https://standards.iteh.ai/catalog/standards/sist/1970df7a-34fb-42aa-88f0-c062dbf32c6/iso-11452-5-2002>

Road vehicles — Component test methods for electrical disturbances from narrowband radiated electromagnetic energy —

Part 5: Stripline

1 Scope

This part of ISO 11452 specifies stripline tests for determining the immunity of electronic components of passenger cars and commercial vehicles to electrical disturbances from narrowband electromagnetic energy, regardless of the vehicle propulsion system (e.g. spark-ignition engine, diesel engine, electric motor). To perform such tests, the equipment harness is exposed to a disturbance field. This technique is limited to equipment harnesses, which have a maximum diameter of one-third the stripline height or less.

The electromagnetic disturbances considered are limited to continuous narrowband electromagnetic fields.

2 Normative reference

The following normative document contains provisions which, through reference in this text, constitute provisions of this part of ISO 11452. For dated references, subsequent amendments to, or revisions of, this publication do not apply. However, parties to agreements based on this part of ISO 11452 are encouraged to investigate the possibility of applying the most recent edition of the normative document indicated below. For undated references, the latest edition of the normative document referred to applies. Members of ISO and IEC maintain registers of currently valid International Standards.

ISO 11452-1, *Road vehicles — Component test methods for electrical disturbances from narrowband radiated electromagnetic energy — Part 1: General and definitions*

3 Terms and definitions

For the purposes of this part of ISO 11452, the terms and definitions given in ISO 11452-1 apply.

4 Test conditions

The users shall specify the test severity level or levels over the frequency range. See annex B for suggested test severity levels.

The useful frequency range of stripline is from 10 kHz to 400 MHz.

Standard test conditions shall be those given in ISO 11452-1 for the following:

- test temperature;
- supply voltage;
- modulation;
- dwell time;
- frequency step sizes;
- definition of test severity levels.

5 Test apparatus

5.1 Stripline

A stripline, ideally, sets up a region of uniform electromagnetic fields. The primary usage of this form of the stripline is to expose at least 1 m of the wiring harness under the active conductor (see Figure 1).

Dimensions in millimetres

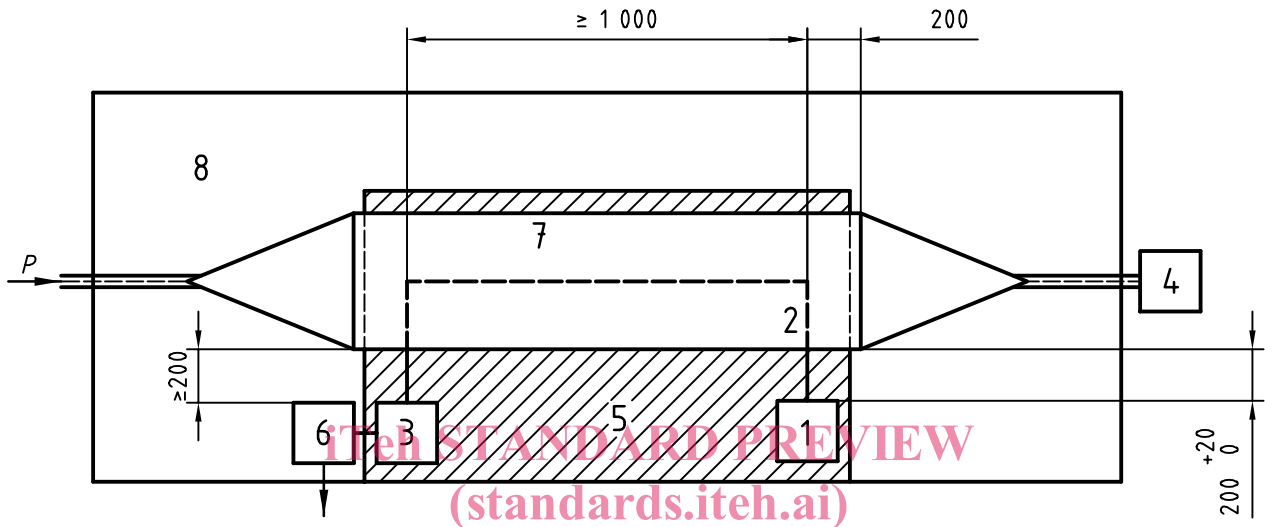

Key

- 1 Device under test
- 2 Wiring harness
- 3 Peripheral
- 4 Terminating resistance
- 5 Insulating base
- 6 Artificial network(s)
- 7 Active conductor
- 8 Ground plane

ISO 11452-5:2002
<https://standards.iteh.ai/catalog/standards/sist/1970df7a-34fb-42aa-88f0-c062dbf32c6/iso-11452-5-2002>

Figure 1 — Example stripline test configuration

5.2 Instrumentation

The instrumentation shown in Figure 2 is the preferred test set-up above 10 kHz.

5.3 Test set-up

5.3.1 Test configuration

The test configuration should be as shown in Figures 1 and 2.

Install the device under test next to the active conductor, with an edge parallel to it. The distance between the closest edges of the active conductor and the device under test shall be (200^{+20}_0) mm. The distance from any peripheral device to the closest edge of the active conductor shall be at least 200 mm.

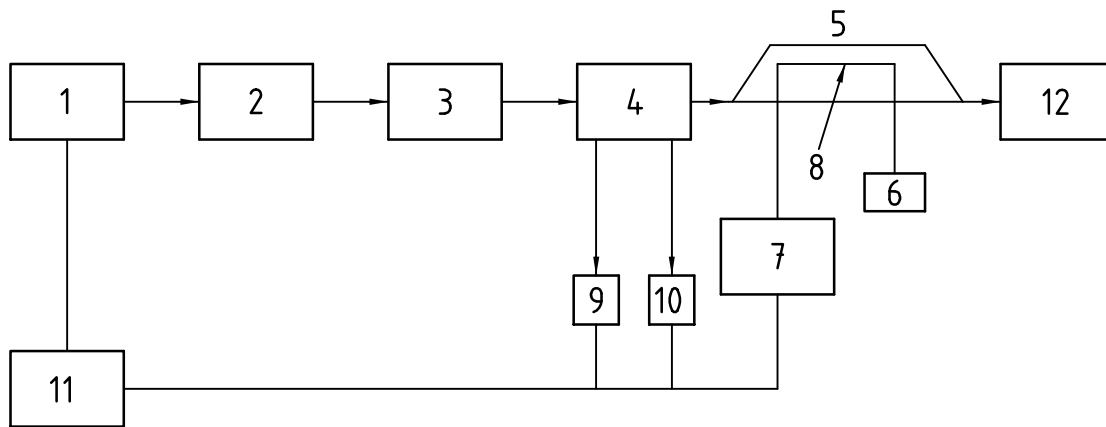
**Key**

- | | |
|----|-----------------------------|
| 1 | Signal generator |
| 2 | RF amplifier |
| 3 | Low pass filter |
| 4 | Directional coupler |
| 5 | Stripline |
| 6 | Device under test |
| 7 | Test monitor |
| 8 | Wiring harness in stripline |
| 9 | Power meter F |
| 10 | Power meter R |
| 11 | Control computer |
| 12 | RF termination |

STANDARD PREVIEW
(standards.iteh.ai)

ISO 11452-5:2002

<https://standards.iteh.ai/catalog/standards/sist/1970df7a-34fb-42aa-88f0-6022b0152030-iso-11452-5-2002>

Figure 2 — Test set-up for stripline test

The wiring harness of the device under test shall be placed on a non-conductive fixture in the centre of the stripline, parallel to its major axis, supported 50 mm above the ground plane. Note that the primary function of the fixture is to lock the positions of the harness and device under test to ensure the most repeatable results and that it should be constructed with this in mind. The length of the longitudinal harness section under the active conductor shall be at least 1 000 mm (see Figure 1). Deviations of the height above the ground table are only permitted near the device under test or the peripheral device or devices.

Place harness branchings to the device under test or to the peripheral devices orthogonally in relation to the longitudinal stripline axis and parallel to the ground plane.

All wires in the harness shall be terminated or open according to the vehicle application. If possible, the actual loads and actuators shall be used. The device under test and the peripherals shall be connected to the ground plane as specified for their installation in the vehicle, i.e. metal housings intended to be electrically connected directly to the vehicle mass (by screws, rivets, etc.) shall be connected to the ground plane by a low impedance connection and devices under test or peripherals not intended to be electrically connected directly to the vehicle mass shall be placed on an insulating support. This insulating support shall have the same height as the insulating support on which the wiring harness is installed.

Power shall be applied to the device under test via a $5 \mu\text{H}/50 \Omega$ artificial network (AN, see annex C for a schematic). Depending on its intended installation in the vehicle, the device under test shall be grounded by one of the following methods.

- If the device under test is remotely grounded (power return line longer than 200 mm), two ANs are required, one for the positive supply line and the other for the power return line.
- If the device under test is locally grounded (power return line 200 mm or shorter), only one AN is required, for the positive supply line.

Energy radiated from the stripline into the enclosure will result in room resonance, which can cause large errors. This effect can be reduced significantly by an improved impedance matching of the stripline and by installation of RF-absorbing material close to the stripline. This material absorbs the energy radiated from the stripline (at frequencies above the multi-mode frequency) and thereby reduces the influence of any reflections from the walls of the shielded room. If absorber-lined shielded rooms are used, these measures are redundant.

5.3.2 Positioning of the device under test

5.3.2.1 General

Three test configurations are possible. Exposure of the wiring harness is the most commonly used. Exposure of the device under test, or exposure of both harness and device under test together, requires special agreement between the users of this part of ISO 11452.

5.3.2.2 Exposure of wiring harness only

This test configuration permits the widest frequency range of testing. The RF fields induced in the harness couple into the device under test using the harness wiring as “antennas” for the received signal.

5.3.2.3 Exposure of the device under test

When it is desired to determine device-under-test immunity directly, the device under test may be placed under the active conductor with the attached wiring harness exiting at 90° to the main axis of the stripline in order to minimize induction into the wiring harness.

Care shall be taken to ensure that the physical size of the device under test does not exceed one third of the height under the active conductor, as otherwise this might distort the test field.

[ISO 11452-5:2002](https://standards.iteh.ai/catalog/standards/sist/1970df7a-34fb-42aa-88f0-c662db152c6/iso-11452-5-2002)

5.3.2.4 Exposure of both device under test and its wiring harness

Both the device under test and its harness may be exposed simultaneously to the field of the stripline.

5.3.3 Input/output leads

The power supply and peripheral devices shall be installed outside the shielded enclosure or shielded and filtered in the shielded enclosure; exclusively passive peripherals (resistors, capacitors, coils, ferrites, mechanical switches, etc.) and radiation-resistant peripherals, may be unshielded and unfiltered in the shielded enclosure.

6 Test procedure

6.1 Test plan

Prior to performing the tests, a test plan shall be generated which shall cover the following:

- frequency range;
- method to be used (6.2.2 or 6.2.3);
- device under test mode of operation;
- device under test acceptance criteria;
- device under test test levels;
- device under test monitoring conditions;
- modulation;

- test report content (see 6.3);
- any special instructions and changes from the standard test.

Every device under test shall be verified under the most significant situations: i.e. at least in stand-by and in a mode where all the actuators can be excited.

6.2 Field calibration methods for substitution method

6.2.1 General

CAUTION — Hazardous voltages and fields may exist within the test area. Care shall be taken to ensure that the requirements for limiting the exposure of humans to RF energy are met.

The test field strength may be determined as specified either in 6.2.2 or 6.2.3, with an empty stripline.

6.2.2 Calculation method

The field strength, E , is calculated as follows:

$$|E| = \frac{\sqrt{P \times Z}}{h}$$

iTeh STANDARD PREVIEW
(standards.iteh.ai)

where

- $|E|$ is the absolute value of the electric field, in volts per metre;
- P is the net power, in watts;
- Z is the characteristic impedance of the stripline, in ohms;
- h is the height of the active conductor above the ground plane, in metres.

A small field probe may be used to verify the calculated calibration curve between the net power into the stripline and the field in the uniform field region.

6.2.3 Field strength measurement method

Alternatively, the relation between field strength and net power may be determined by placing a calibrated field probe as close as possible to the centre of the stripline, with respect to the longitudinal and transverse axes under the active conductor.

If the device under test or field probe occupies more than one-third of the height between the active conductor and the ground plane, the test field will be perturbed, resulting in a stronger field than that indicated by the measured net power.

6.3 Test report

As required by the test plan, a test report shall be submitted detailing information on the test equipment, test site, systems tested, frequencies, power levels, system interactions and any other relevant information regarding the test.