

INTERNATIONAL
STANDARD

ISO
10191

Second edition
1995-12-15

**Passenger car tyres — Verifying tyre
capabilities — Laboratory test methods**

iTeh STANDARD PREVIEW

*Pneumatiques pour voitures particulières — Vérification de l'aptitude des
pneumatiques — Méthodes d'essai en laboratoire*

ISO 10191:1995

<https://standards.iteh.ai/catalog/standards/sist/19ae7f95-c79b-4e09-bb51-4ddd6b3261d5/iso-10191-1995>



Reference number
ISO 10191:1995(E)

Foreword

ISO (the International Organization for Standardization) is a worldwide federation of national standards bodies (ISO member bodies). The work of preparing International Standards is normally carried out through ISO technical committees. Each member body interested in a subject for which a technical committee has been established has the right to be represented on that committee. International organizations, governmental and non-governmental, in liaison with ISO, also take part in the work. ISO collaborates closely with the International Electrotechnical Commission (IEC) on all matters of electrotechnical standardization.

Draft International Standards adopted by the technical committees are circulated to the member bodies for voting. Publication as an International Standard requires approval by at least 75 % of the member bodies casting a vote.

International Standard ISO 10191 was prepared by Technical Committee ISO/TC 31, *Tyres, rims and valves*, Subcommittee SC 3, *Passenger car tyres and rims*.

This second edition cancels and replaces the first edition (ISO 10191:1993), which has been technically revised.

Annexes A and B of this International Standard are for information only.

© ISO 1995

All rights reserved. Unless otherwise specified, no part of this publication may be reproduced or utilized in any form or by any means, electronic or mechanical, including photocopying and microfilm, without permission in writing from the publisher.

International Organization for Standardization
Case Postale 56 • CH-1211 Genève 20 • Switzerland

Printed in Switzerland

Passenger car tyres — Verifying tyre capabilities — Laboratory test methods

1 Scope

This International Standard specifies test methods for verifying the capabilities of tyres for passenger cars. Of the test methods presented, only some may be required depending on the type of tyre to be tested.

The tests are carried out in a laboratory under controlled conditions.

It includes a strength test for assessing the capability of the tyre structure, with respect to braking energy, in the tread area.

A second test, the bead unseating test, assesses the resistance of the tyre to bead unseating. It applies to tubeless tyres only.

A third test, the endurance test, assesses the resistance of the tyre with respect to service at full load and moderate speed over long distances.

The fourth test, the high speed test, assesses the capability of the tyre according to its speed category.

The test methods presented in this International Standard are not intended for gradation of tyre performance or quality levels.

This International Standard applies to all passenger car tyres.

2 Normative reference

The following standard contains provisions which, through reference in this text, constitute provisions of this International Standard. At the time of publication, the edition indicated was valid. All standards are subject to revision, and parties to agreements based on this International Standard are encouraged to investigate the possibility of applying the most re-

cent edition of the standard indicated below. Members of IEC and ISO maintain registers of currently valid International Standards.

ISO 4223-1:1989, *Definitions of some terms used in the tyre industry — Part 1: Pneumatic tyres.*

3 Definitions

For the purposes of this International Standard, the definitions given in ISO 4223-1 and the following definitions apply.

3.1 bead separation: Breakdown of bond between components in the bead area.

3.2 belt separation: Parting of rubber compound between belt layers or between belts and plies.

3.3 chunking: Breaking away of pieces of the tread.

3.4 cord separation: Cord parting from adjacent rubber compounds.

3.5 cracking: Any parting within the tread, sidewall or innerliner of the tyre extending to cord material.

3.6 innerliner separation: Parting of innerliner from cord material in the carcass.

3.7 open splice: Any parting at any junction of tread, sidewall or innerliner that extends to cord material.

3.8 ply separation: Parting of rubber compound between adjacent plies.

3.9 sidewall separation: Parting of the rubber compound from the cord material in the sidewall.

3.10 tread separation: Pulling away of the tread from the tyre carcass.

3.11 test rim: Any rim on which the tyre may be fitted that conforms to the dimensions of the recommended rims for the particular tyre designation and type.

3.12 test drum speed: Peripheral speed of the steel test drum.

3.13 maximum load rating: Maximum load that the tyre is rated to carry according to its speed category.

4 Test equipment

The test equipment consists of items in 4.1 to 4.4.

4.1 Test drum, cylindrical driven flywheel (drum) having a diameter of 1,7 m $^{+2}_0$ % or 2 m $^{+2}_0$ %.

The surface of the drum shall be smooth steel. The width of the test surface shall be equal to or exceed the overall width of the test tyre.

For the test drum the loading device shall have a capacity of at least 1 000 kg and the accuracy shall be within ± 1 % of the full scale.

For the test drum, the speed capability of the equipment shall be adequate for the requirements of the test methods. The accuracy of the test drum speed shall be within $^{+2}_0$ km/h.

4.2 Plunger, cylindrical steel plunger of sufficient length with a hemispherical end and a diameter of 19 mm $\pm 1,6$ mm.

For the plunger equipment, the loading device shall permit gradual application of the force. Indicators of displacement and force provided shall have an accuracy within ± 1 % of full scale.

For the plunger equipment, the displacement speed shall be controlled with an accuracy within ± 3 % of the full scale.

4.3 Bead unseating block, of one of the two types in figure 1.

The bead unseating block loading device shall permit progressive application of the force. Indicators of displacement and force provided shall have an accuracy within ± 1 % of full scale.

The displacement speed of the head unseating block shall be controlled with an accuracy within ± 3 % of the full scale.

4.4 Inflation pressure gauges, with a maximum scale value of at least 500 kPa with an accuracy within ± 5 kPa.

5 Testing

5.1 Strength test

5.1.1 Preparation of tyre

5.1.1.1 Mount the tyre on a test rim and inflate it to the pressure specified in table 1.

Table 1 — Inflation pressures for resistance test

Tyre type	Pressure kPa
Standard	180
Reinforced/extra load	220
T type (temporary use)	360
NOTE — In case of other tyre types, the tyre manufacturer shall send a request to ISO for insertion in this table of a different test pressure, with reasons.	

5.1.1.2 Maintain the assembly at test room temperature for at least 3 h.

5.1.2 Test procedure

5.1.2.1 Readjust the tyre pressure to that specified in 5.1.1.1 and mount the assembly on a fixture.

5.1.2.2 Position the plunger as near to the centre-line as possible, avoiding penetration into the tread grooves, and force the plunger perpendicularly into the tread at a rate of 50 mm/min $\pm 2,5$ mm/min.

5.1.2.3 Record the force and penetration at the moment of breaking (see also 5.1.2.7) at each of five test points approximately equally spaced around the tyre circumference. Check the pressure before moving to the next test point.

5.1.2.4 If the tyre fails to break before the plunger is stopped on reaching the rim, then the tyre is deemed to have passed the test at that point.

Dimensions in millimetres
 Material: Al-Si2 Mg Ti or Al-Si7 Mg0,3 (see [2])
 Condition: TF (see [1])
 Surface roughness: Ra 1,25 µm

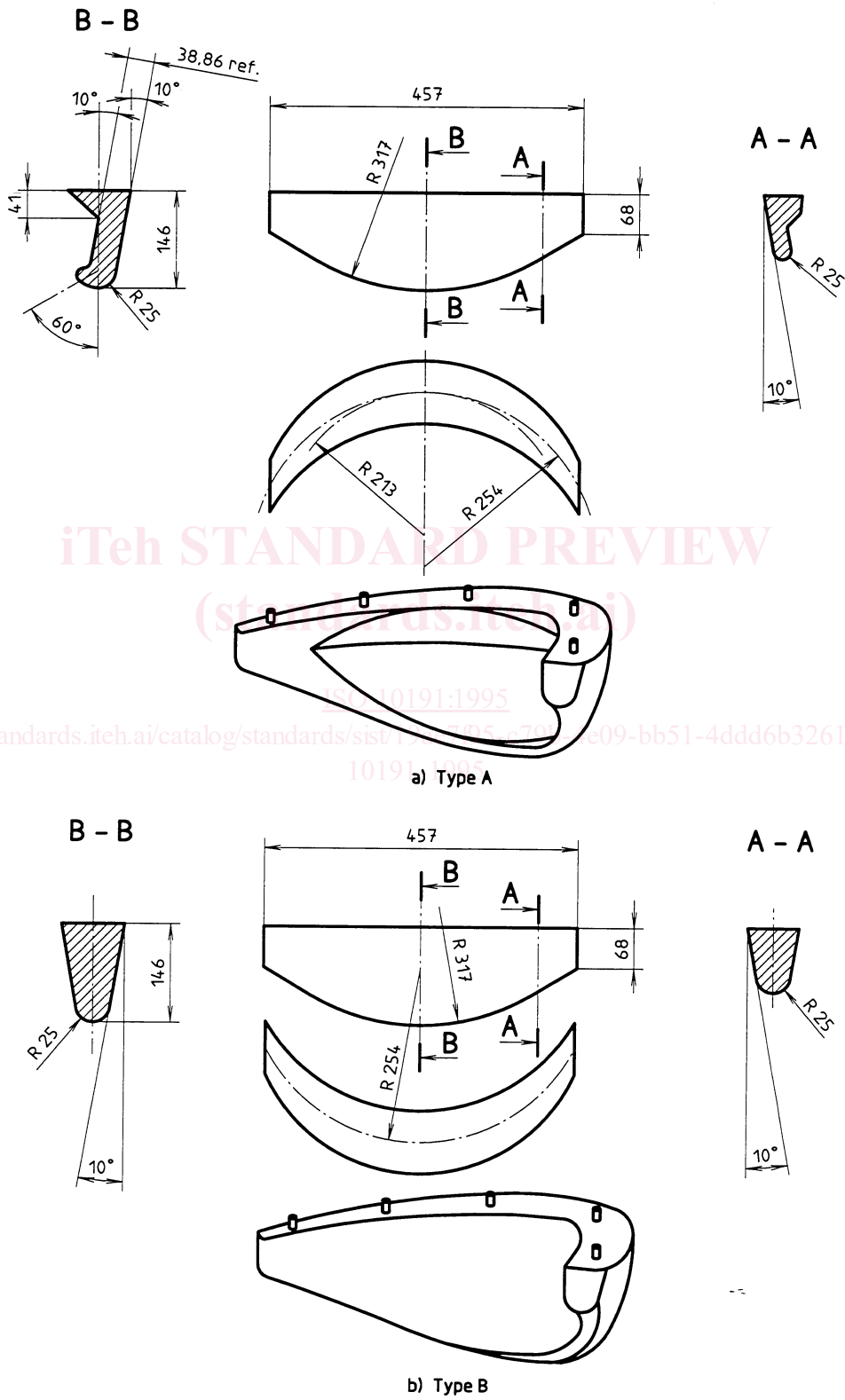

Figure 1 — Diagrams of bead unseating blocks

5.1.2.5 Compute the breaking energy, W , in joules for each test point, except those considered by 5.1.2.4, by means of the following formula:

$$W = \frac{F \times P}{2\ 000}$$

where

F is the force, in newtons;

P is the penetration, in millimetres.

5.1.2.6 Determine the breaking energy value for the tyre by computing the average of the values obtained.

5.1.2.7 When an appropriate device which automatically evaluates the value of the energy W is available, the penetration can be stopped shortly after having achieved the prescribed value.

5.1.2.8 In the case of tubeless tyres, means may be provided to ensure the retention of the inflation pressure for the duration of the test.

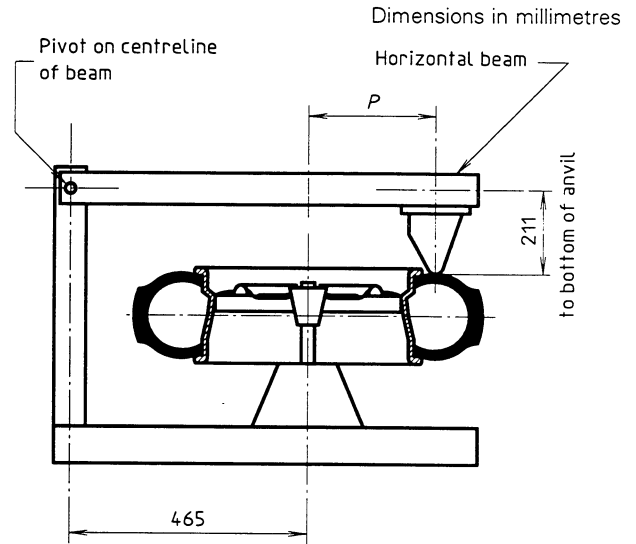

Figure 2 — Bead unseating fixture

Table 2 — Distance P from bead unseating block (see figure 2)

Dimensions in millimetres

Nominal rim diameter code	Dimension P	
	T type temporary use spare tyres	All other tyres
10		216
12		241
13		254
14	226	267
15	239	279
16	251	292
17	269	305
18	290	318
19	305	330
290		229
315		241
340		254
365	—	267
390		279
415		292

5.2 Bead unseating test

This test applies to tubeless tyres only.

5.2.1 Preparation of tyre

5.2.1.1 Wash the tyre, dry it at the beads, and mount it without lubrication or adhesive on a clean, painted test rim. The rim contour shall be one of those specified for the fitment of the test tyre.

5.2.1.2 Mount the tyre on a test rim and inflate it to the pressure specified in table 1.

5.2.2 Test procedure

5.2.2.1 Mount the tyre and rim assembly on a fixture as shown in figure 2.

5.2.2.2 Position the bead unseating block (4.3) against the tyre sidewall at a horizontal distance P as shown in table 2.

5.2.2.3 Apply a force through the block to the tyre outer sidewall at a rate of 50 mm/min \pm 2,5 mm/min.

5.2.2.4 Increase the force until the bead block unseats or until the prescribed value is reached.

5.2.2.5 Repeat the test at least four times at places approximately equally spaced around the tyre circumference.

5.3 Endurance test

5.3.1 Preparation of tyre

5.3.1.1 Mount the tyre on a test rim and inflate it to the pressure specified in table 1.

5.3.1.2 Maintain the tyre and rim assembly at an ambient temperature of not less than 35 °C for at least 3 h.

5.3.2 Test procedure

5.3.2.1 Readjust the tyre pressure to the value specified in 5.3.1.1 immediately before testing.

5.3.2.2 Mount the tyre and rim assembly on a test axle so that the tyre may be pressed radially against the outer face of test drum.

5.3.2.3 During the test the ambient temperature, at a distance of not less than 150 mm and not more than 1 m from the tyre, shall be at least 35 °C. No provision shall be made for cooling the tyre during the test.

5.3.2.4 Conduct the test, without interruptions, at not less than 80 km/h test speed with loads and test periods not less than those shown in table 3.

Table 3 — Test parameters for endurance

Test period	Duration	Load as a percentage of tyre maximum load rating
	min.	min.
1	4 h	85 %
2	6 h	90 %
3	24 h	100 %

5.3.2.5 Throughout the test, the inflation pressure shall not be corrected and the test loads shall be kept constant at the value corresponding to each test period.

5.4 High speed test

For those tyres not marked with a service description, note should be taken of the additional test conditions given in annex A.

5.4.1 Preparation of tyre

5.4.1.1 Mount the tyre on a test rim, inflate it to a pressure related to its speed symbol, tyre version and load type, as shown in table 4.

Table 4 — Inflation pressures for high speed test

Speed symbol	Inflation pressure kPa				
	Diagonal			Radial and bias-belted	
	4PR	6PR	8PR	Normal (standard)	Reinforced (extra load)
L, M, N	230	270	300	240	280
P, Q, R, S	260	300	330	260	300
T, U, H	280	320	350	280	320
V	300	340	370	300	340
W, Y	—	—	—	320	360

NOTE — In case of high pressure "temporary use spare" tyres, identified by a prefix T in the size designation, the tyre shall be inflated to 420 kPa.

The tyre manufacturer may request, giving reasons, the use of a different test inflation pressure. In such a case, the tyre shall be inflated to that pressure.

5.4.1.2 Maintain the tyre and rim assembly at test room temperature for not less than 3 h.

5.4.2 Test method

5.4.2.1 Before or after mounting the tyre and rim assembly on a test axle, readjust the tyre pressure to that specified in 5.4.1.

5.4.2.2 Press the tyre and rim assembly against the outer face of the test drum.

5.4.2.3 Apply a load equal to 80 % of the maximum load rating of the tyre to the test axle.

For tyres of speed symbol V, the test load shall be equal to 73 % of the load corresponding to their load index, i.e. 80 % of the maximum load allowed at 240 km/h.

For tyres of speed symbol W and Y, the test load shall be equal to 68 % of the load corresponding to their load index, i.e. 80 % of the maximum load allowed at 270 km/h and 300 km/h, respectively.

5.4.2.4 Throughout the test the inflation pressure shall not be corrected and the test load shall be kept constant.

5.4.2.5 During the test, the temperature in the test room shall be maintained at between 20 °C and 30 °C, or at a higher temperature if the tyre manufacturer agrees.

5.4.2.6 Carry the test through without interruptions as follows, in relation to the tyre speed symbol and the test drum diameter.

a) For tyres of speed symbol L to W

The initial test speed is equal to the tyre's speed category

- less 40 km/h on a 1,7 m drum, or
- less 30 km/h on a 2 m drum.

- 1) Accelerate the equipment at a constant rate such that the initial test speed is reached at the end of 10 min from start-up.
- 2) Operate the equipment with the test drum speed at the initial test speed for 10 min;

— then, at the initial test speed plus 10 km/h for at least 10 min;

— then, at the initial test speed plus 20 km/h for at least 10 min;

— then, at the initial test speed plus 30 km/h for at least 10 min;

— and finally, for a further 10 min, at the initial test speed plus

30 km/h on one or other of the drums, or

40 km/h on the 1,7 m drum only.

b) For tyres of speed symbol Y

The test conditions on a 2 m drum are the following.

- 1) Accelerate the equipment at a constant rate such that a speed of 270 km/h is reached at the end of 10 min from start-up.
- 2) Operate the equipment at 270 km/h for 20 min;
 - then, at 280 km/h for 10 min;
 - then, at 290 km/h for 10 min;
 - and finally, at 300 km/h for 10 min.

6 Requirements

6.1 Test sample

Three tyres with identical characteristics, e.g. size designation and service description or maximum load rating and speed capability, shall comprise a test sample:

- a) one tyre shall be used for the measurement of bead unseating and then of strength;
- b) a second tyre for the endurance test;
- c) a third for the high-speed performance test.

The pressures, loads speeds and durations shall be as specified for each test method.

Each test sample shall conform to the requirements specified in 6.2 to 6.5 as appropriate.

6.2 Strength test

6.2.1 Each test sample shall meet at least the requirements for minimum breaking energy specified in table 5, when tested in accordance with 5.1.

Table 5 — Minimum breaking energy

Tyre version	Breaking energy min. J
Standard	295
Reinforced/extra load	585

NOTE — In the case of other tyre versions or when pressures differ from those recommended for tyre measurements in table 1, the value of the minimum breaking load E_{\min} , in joules, is calculated as follows:

$$E_{\min} = 7,35(p_1 - 140)$$

where p_1 is the inflation pressure, in kilopascals, specified for the test.

6.2.2 For tyres with nominal section width less than 160 mm, the required energy value shall be reduced by 25 %.

6.2.3 For high pressure "temporary use spare" tyres, identified by a prefix T in the size designation, the energy required shall be

- 295 J for tyres with a maximum load rating of 400 kg and above;
- 220 J for tyres with a maximum load rating below 400 kg.

6.3 Bead unseating resistance (tubeless tyres)

6.3.1 When tested in accordance with 5.2, the applied force required to unseat the tyre bead at the point of contact shall not be less, in relation to the nominal section width of the tyre, than that shown in table 6.

Table 6 — Bead unseating

Nominal section, S , width mm	Force N
$S < 160$	6 670
$160 \leq S < 205$	8 890
$S \geq 205$	11 120

6.3.2 For high pressure "temporary use spare" tyres, identified by a prefix T in the size designation, the force required to unseat the tyre bead shall not be less, in relation to the tyre load index, than that shown in table 7.

Table 7 — Bead unseating for temporary use spare tyres

Load index	Force N
≤ 75	6 670
76 to 92	8 890
≥ 93	11 120

6.4 Endurance test

6.4.1 When the tyre has been subjected to the laboratory endurance test specified in 5.3, using a test rim and a valve which undergo no permanent deformation and allow no loss of air, there shall be no visual evidence of tread, sidewall, ply, cord, innerliner, belt or bead separation, chunking, open splices, cracking or broken cords.

6.4.2 The tyre pressure measured immediately after the test shall not be less than the initial pressure specified in 5.3.1.1.

6.5 High-speed test

6.5.1 After completion of the laboratory high-speed test specified in 5.4 using a test rim and a valve which undergo no permanent deformation and allow no loss of air, there shall be no visual evidence of tread, sidewall, ply, cord, innerliner, belt or bead separation, chunking, open splices, cracking or broken cords.

6.5.2 The tyre pressure measured immediately after the test shall not be less than the initial pressure specified in 5.4.1.1.

Annex A (informative)

High-speed test — Test conditions for tyres without service description marking

A.1 Scope

This annex provides additional information on test conditions for those tyres which are not marked with a service description.

The following additional conditions apply.

A.2 Test conditions

A.2.1 Inflation pressures

The inflation pressures (see 5.4.1.1) in table A.1 shall be used.

Table A.1 — Reference pressures

Tyre type	Inflation pressure kPa
VR	300
ZR	320
Radial	280
Diagonal and bias-belted:	
4 PR or B	230
6 PR or C	270
8 PR or D	300

Table A.2 — Speed categories

Tyre type	Speed category km/h
VR	> 210 ¹⁾
ZR	> 240 ¹⁾
Radial	170
Diagonal or bias-belted:	
Rim diameter code	
10	120
12	140
≥ 13	150
1) Consult the tyre manufacturer for the maximum speed.	

A.2.2.3 The initial test speed for non-speed-marked tyres is the speed category shown in table A.2 reduced as in 5.4.2.6 a).

A.2.2.4 In the case of tyres marked "ZR", suitable for speeds higher than 300 km/h, two separate high-speed tests shall be performed on two samples of the same type. The first test shall be performed as specified in paragraph 5.4.2.6 b), applying a test load which is 80 % of the load allowed for operation at a speed of 300 km/h. The second test relative to assessment of top tyre performances shall be performed on the second sample using the following procedure and on a test drum with a diameter of 2 m.

Apply a test load equal to 80 % of the load allowed for operation at the top speed capability. Accelerate the equipment at a constant rate in order to reach the maximum speed certified for the tyre at the end of 10 min from start-up. Operate the equipment with the test drum speed corresponding to the maximum speed for 5 min.