



Designation: C 1231/C 1231M – 00^{e1}

Standard Practice for Use of Unbonded Caps in Determination of Compressive Strength of Hardened Concrete Cylinders¹

This standard is issued under the fixed designation C 1231/C 1231M; the number immediately following the designation indicates the year of original adoption or, in the case of revision, the year of last revision. A number in parentheses indicates the year of last reapproval. A superscript epsilon (ϵ) indicates an editorial change since the last revision or reapproval.

^{e1} NOTE—Equations in 9.2, 9.3, and X1.3 were editorially corrected August 2000.

1. Scope

1.1 This practice covers requirements for a capping system using unbonded caps for testing concrete cylinders molded in accordance with Practice C 31/C 31M or C 192/C 192M. *Unbonded neoprene caps of a defined hardness are permitted to be used for testing for a specified maximum number of reuses without qualification testing up to a certain concrete compressive strength level. Above that strength, level neoprene caps will require qualification testing. Qualification testing is required for all elastomeric materials other than neoprene regardless of the concrete strength.*

1.2 Unbonded caps are not to be used for acceptance testing of concrete with compressive strength below 1500 psi [10 MPa] or above 12 000 psi [85 MPa].

1.3 The values stated in either inch-pound or SI units shall be regarded as standard. SI units are shown in brackets. That values stated in each system may not be exact equivalents; therefore, each system must be used independently of the other, without combining the values in any way.

1.4 *This standard does not purport to address all of the safety concerns, if any, associated with its use. It is the responsibility of the user of this standard to establish appropriate safety and health practices and determine the applicability of regulatory limitations prior to use.* For a specific hazard statement, see Note 4.

2. Referenced Documents

2.1 ASTM Standards:

C 31/C 31M Practice for Making and Curing Concrete Test Specimens in the Field²

C 39 Test Method for Compressive Strength of Cylindrical Concrete Specimens²

C 192/C 192M Practice for Making and Curing Concrete Test Specimens in the Laboratory²

¹ This practice is under the jurisdiction of ASTM Committee C09 on Concrete and Concrete Aggregates and is the direct responsibility of Subcommittee C09.61 on Testing Concrete for Strength.

Current edition approved Jan. 10, 2000. Published April 2000. Originally published as C 1231–93. Last previous edition C 1231–99.

² Annual Book of ASTM Standards, Vol 04.02.

C 617 Practice for Capping Cylindrical Concrete Specimens²

D 2000 Classification System for Rubber products in Automotive Applications³

D 2240 Test Method for Rubber Property—Durometer Hardness⁴

3. Terminology

3.1 Definitions of Terms Specific to This Standard:

3.1.1 *pad, n*—an unbonded elastomeric pad.

3.1.2 *unbonded cap, n*—a metal retainer and an elastomeric pad.

4. Significance and Use

4.1 This practice provides for using an unbonded capping system in testing hardened concrete cylinders made in accordance with Practices C 31/C 31M or C 192/C 192M in lieu of the capping systems described in Practice C 617.

4.2 The elastomeric pads deform in initial loading to conform to the contour of the ends of the cylinder and are restrained from excessive lateral spreading by plates and metal rings to provide a uniform distribution of load from the bearing blocks of the testing machine to the ends of the concrete or mortar cylinders.

5. Materials and Apparatus

5.1 Materials and equipment necessary to produce ends of the reference cylinders that conform to planeness requirements of Test Method C 39 and the requirements of Practice C 617. This may include grinding equipment or capping materials and equipment to produce neat cement paste, high strength gypsum plaster, or sulfur mortar caps.

5.2 Elastomeric Pads:

5.2.1 Pads shall be $\frac{1}{2} \pm \frac{1}{16}$ in. [13 ± 2 mm] thick and the diameter shall not be more than $\frac{1}{16}$ in. [2 mm] smaller than the inside diameter of the retaining ring.

5.2.2 Pads shall be made from polychloroprene (neoprene) meeting the requirements of Classification D 2000 as follows:

³ Annual Book of ASTM Standards, Vol 09.02.

⁴ Annual Book of ASTM Standards, Vol 09.01.

Shore A Durometer	Classification D 2000 Line Call-Out
50	M2BC514
60	M2BC614
70	M2BC714

The tolerance on Shore A durometer hardness is ± 5 . Table 1 provides requirements for use of caps made from material meeting the requirements of Classification D 2000, above.

5.2.3 Other elastomeric materials that meet the performance requirements of qualification tests in Section 8 are permitted.

5.2.4 Elastomeric pads shall be supplied with the following information:

- 5.2.4.1 The manufacturer's or supplier's name,
- 5.2.4.2 The Shore A hardness, and
- 5.2.4.3 The applicable range of concrete compressive strength from Table 1 or from qualification testing.

5.2.5 The user shall maintain a record indicating the date the pads are placed in service, the pad durometer, and the number of uses to which they have been subjected.

5.3 Retainers, shall be made of metal that will prove durable in repeated use (Note 1). The cavity in the metal retainers shall have a depth at least twice the thickness of the pad. The inside diameter of the retaining rings shall not be less than 102 % or greater than 107 % of the diameter of the cylinder. The surfaces of the metal retainer which contact the bearing blocks of the testing machine shall be plane to within 0.002 in. [0.05 mm]. The bearing surfaces of the retainers shall not have gouges, grooves, or indentations greater than 0.010 in. [0.25 mm] deep or greater than 0.05 in.² [32 mm²] in surface area.

NOTE 1—Retainers made from steel and some aluminum alloys have been found acceptable. Steel retaining rings that have been used successfully with 1/2-in. [13-mm] neoprene pads are shown in Fig. 1. Retainer design and metals used are subject to the performance and acceptance requirements of Section 8.

6. Test Specimens

6.1 The specimens shall be either 6 by 12 in. [150 by 300 mm] or 4 by 8 in. [100 by 200 mm] cylinders made in accordance with Practices C 31/C 31M or C 192/C 192M. Neither end of a cylinder shall depart from perpendicularity to the axis by more than 0.5° (approximately equivalent to 1/8 in. in 12 in. [3 mm in 300 mm]). No individual diameter of a cylinder may differ from any other diameter by more than 2 %.

NOTE 2—One method of measuring the perpendicularity of ends of cylinders is to place a try square across any diameter and measure the departure of the longer blade from an element of the cylindrical surface. An alternative method is to place the end of the cylinder on a plane surface and support the try square on that surface.

TABLE 1 Requirements for Use of Polychloroprene (Neoprene) Pads

Cylinder Compressive Strength, psi [MPa]	Shore A Durometer Hardness	Qualification Tests Required	Maximum Reuses ^A
1 500 to 6 000 [10 to 40]	50	none	100
2 500 to 7 000 [17 to 50]	60	none	100
4 000 to 7 000 [28 to 50]	70	None	100
7 000 to 12 000 [50 to 80]	70	Required	50
Greater than 12,000 [80]		not permitted	

^A Maximum number of reuses. Will be less if pads wear, crack or split. See Note 6.

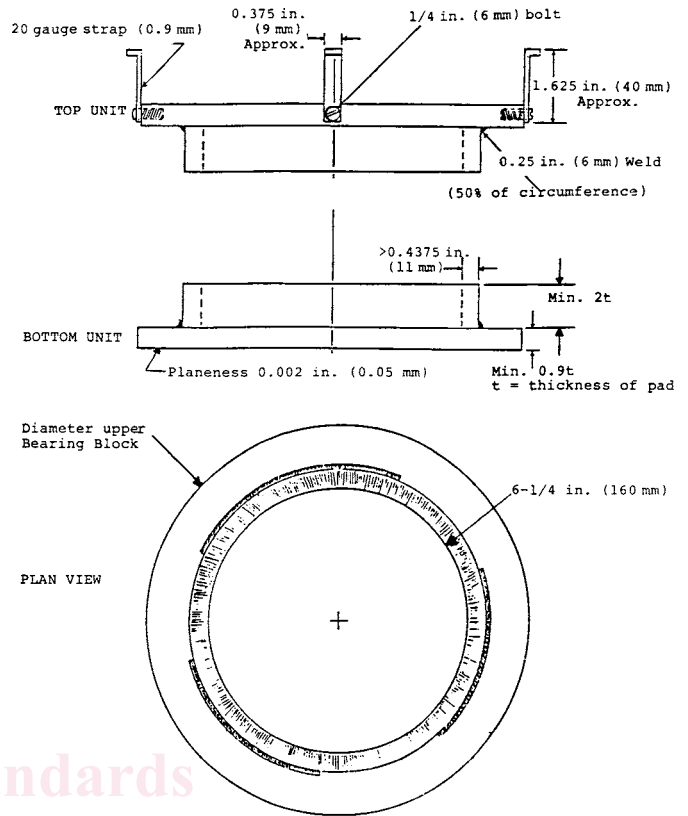

FIG. 1 Example of Steel Retaining Rings for 6 by 12 in. [150 by 300 mm] Cylinders (Nonmandatory)

6.2 Depressions under a straight edge measured with a round wire gage across any diameter shall not exceed 0.20 in. [5 mm]. If cylinder ends do not meet this tolerance, the cylinder shall not be tested unless irregularities are corrected by sawing or grinding.

7. Procedure

7.1 Unbonded caps are permitted to be used on one or both ends of a cylinder in lieu of a cap or caps meeting Practice C 617, provided they meet the requirements of Section 5.

7.2 Examine the pads for excessive wear or damage (Note 6). Replace pads which have cracks or splits exceeding 3/8 in. [10 mm] in length regardless of depth. Insert the pads in the retainers before they are placed on the cylinder (Note 3).

NOTE 3—Some manufacturers recommend dusting the pads and the ends of the cylinders with corn starch or talcum powder prior to testing.

NOTE 4—**Caution:** Concrete cylinders tested with unbonded caps rupture more violently than comparable cylinders tested with bonded caps. As a safety precaution the cylinder testing machine must be equipped with a protective cage. In addition, some users have reported damage to testing machines from the sudden release of energy stored in the elastomeric pads.

7.3 Center the unbonded cap or caps on the cylinder and place the cylinder on the lower bearing block of the testing machine. Carefully align the axis of the cylinder with the center of thrust of the testing machine by centering the upper retaining ring on the spherically seated bearing block. As the spherically seated block is brought to bear on the upper