

---

---

**Connections for hydraulic fluid power  
and general use — Hose fittings —**

**Part 3:**  
Hose fittings with ISO 6162 flange ends

*Raccordements pour transmissions hydrauliques et applications  
générales — Flexibles de raccordement —  
Partie 3: Flexibles avec bride conforme à l'ISO 6162*

ISO 12151-3:1999

<https://standards.iteh.ai/catalog/standards/sist/0bbce1aa-765e-4e23-a2a6-5e57d193c00b/iso-12151-3-1999>



## Foreword

ISO (the International Organization for Standardization) is a worldwide federation of national standards bodies (ISO member bodies). The work of preparing International Standards is normally carried out through ISO technical committees. Each member body interested in a subject for which a technical committee has been established has the right to be represented on that committee. International organizations, governmental and non-governmental, in liaison with ISO, also take part in the work. ISO collaborates closely with the International Electrotechnical Commission (IEC) on all matters of electrotechnical standardization.

International Standards are drafted in accordance with the rules given in the ISO/IEC Directives, Part 3.

Draft International Standards adopted by the technical committees are circulated to the member bodies for voting. Publication as an International Standard requires approval by at least 75 % of the member bodies casting a vote.

International Standard ISO 12151-3 was prepared by Technical Committee ISO/TC 131, *Fluid power systems*, Subcommittee SC 4, *Connectors and similar products and components*.

ISO 12151 consists of the following parts, under the general title *Connections for hydraulic fluid power and general use — Hose fittings*:

- Part 1: Hose fittings with ISO 8434-3 O-ring face seal ends
- Part 2: Hose fittings with ISO 8434-1 and 8434-4 24° cone connector ends with O-rings
- Part 3: Hose fittings with ISO 6162 flange ends
- Part 4: Hose fittings with ISO 6149 metric stud ends
- Part 5: Hose fittings with ISO 8434-2 37° flared ends

© ISO 1999

All rights reserved. Unless otherwise specified, no part of this publication may be reproduced or utilized in any form or by any means, electronic or mechanical, including photocopying and microfilm, without permission in writing from the publisher.

International Organization for Standardization  
Case postale 56 • CH-1211 Genève 20 • Switzerland  
Internet iso@iso.ch

Printed in Switzerland

## Introduction

In hydraulic fluid power systems, power is transmitted and controlled through a liquid under pressure within an enclosed circuit. In general applications, the fluid may be conveyed under pressure.

Components are connected through their ports by stud ends on fluid conductor fittings to tubes/pipes or to hose fittings and hoses.

## iTeh STANDARD PREVIEW (standards.iteh.ai)

[ISO 12151-3:1999](https://standards.iteh.ai/catalog/standards/sist/0bbce1aa-765e-4e23-a2a6-5e57d193c00b/iso-12151-3-1999)

<https://standards.iteh.ai/catalog/standards/sist/0bbce1aa-765e-4e23-a2a6-5e57d193c00b/iso-12151-3-1999>

**iTeh STANDARD PREVIEW**  
**(standards.iteh.ai)**

ISO 12151-3:1999

<https://standards.iteh.ai/catalog/standards/sist/0bbce1aa-765e-4e23-a2a6-5e57d193c00b/iso-12151-3-1999>

# Connections for hydraulic fluid power and general use — Hose fittings —

## Part 3: Hose fittings with ISO 6162 flange ends

### 1 Scope

This part of ISO 12151 specifies the general and dimensional requirements for the design and performance of flange hose fittings, made of carbon steel, for nominal hose inside diameters of 12,5 mm to 51 mm inclusive, in accordance with ISO 4397, for use with ports and clamps in accordance with ISO 6162.

NOTE 1 Materials other than carbon steel may be supplied as agreed between the manufacturer and user.

NOTE 2 For hose fittings used in hydraulic and pneumatic braking systems on road vehicles (as defined in the scope of ISO/TC 22/SC 2), see ISO 4038, ISO 4039-1 and ISO 4039-2.

These hose fittings (see Figure 1 for a typical example) are for use in hydraulic fluid power systems with hose that meets the requirements of the respective hose standards and in general applications with suitable hoses.

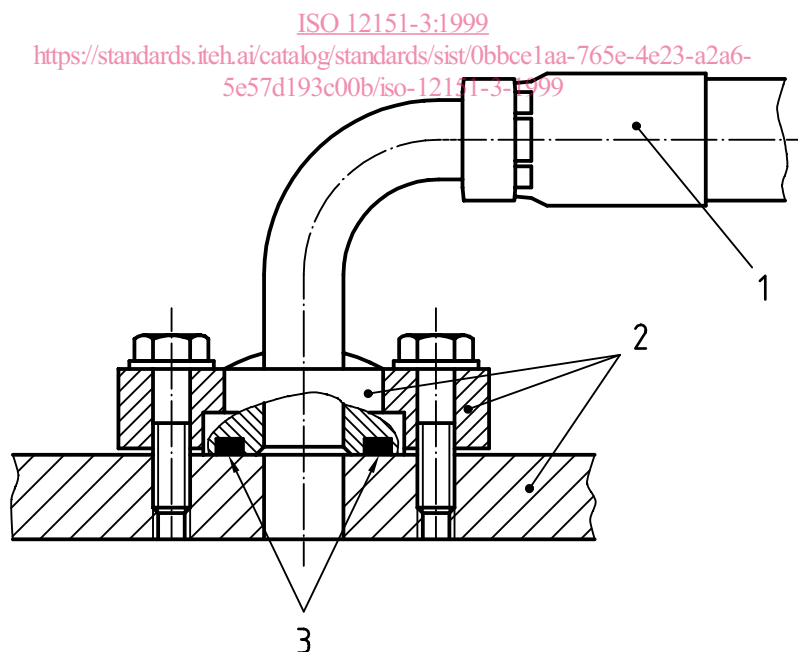

#### Key

- 1 Hose fitting
- 2 Port, flanged head and clamp per ISO 6162
- 3 O-ring seal

Figure 1 — Typical example of hose fitting connection with ISO 6162 flange end

## 2 Normative references

The following normative documents contain provisions which, through reference in this text, constitute provisions of this part of ISO 12151. For dated references, subsequent amendments to, or revisions of, any of these publications do not apply. However, parties to agreements based on this part of ISO 12151 are encouraged to investigate the possibility of applying the most recent editions of the normative documents indicated below. For undated references, the latest edition of the normative document referred to applies. Members of ISO and IEC maintain registers of currently valid International Standards.

ISO 4397:1993, *Fluid power systems and components — Connectors and associated components — Nominal outside diameters of tubes and nominal inside diameters of hoses.*

ISO 5598:1985, *Fluid power systems and components — Vocabulary.*

ISO 6162:1994, *Hydraulic fluid power — Four-screw split-flange connections for use at pressures of 2,5 MPa to 40 MPa (25 bar to 400 bar) — Type I metric series and type II inch series.*

ISO 8434-5:1995, *Metallic tube connections for fluid power and general use — Part 5: Test methods for threaded hydraulic fluid power connections.*

ISO 9227:1990, *Corrosion tests in artificial atmospheres — Salt spray tests.*

## 3 Terms and definitions

For the purposes of this part of ISO 12151, the terms and definitions given in ISO 5598 apply.

## 4 Performance requirements

Hose assemblies shall meet the performance requirements specified in the appropriate hose specification without leakage or failure.

The working pressure of the hose assembly shall be the lower of the pressures given for its flange style (pressure series) and size in ISO 6162, and in the relevant hose specification.

Hose fitting tests shall be conducted in accordance with ISO 8434-5 for the working pressure of the hose assembly. The hose assembly shall undergo a cyclic endurance test and meet or exceed the number of cycles specified in the relevant hose specification.

## 5 Designation of hose fittings

**5.1** Hose fittings shall be designated by an alphanumeric code to facilitate ordering. They shall be designated by ISO 12151-3, followed by a spaced hyphen, then the shape symbol (see Table 1), followed by another spaced hyphen, the style letter L for 2,5 MPa to 35 MPa (25 bar to 350 bar) flanges or the style letter S for 40 MPa (400 bar) flanges in accordance with ISO 6162 followed by the flange size from ISO 6162, a multiplication symbol (×) and the hose size (nominal hose inside diameter in accordance with ISO 4397).

### EXAMPLE

A 45° elbow hose fitting, with a medium drop length (E45) with a 40 MPa (400 bar) flanged head (S) 32 mm nominal flange size and 31,5 nominal ID hose, is designated as follows:

**ISO 12151-3 - E45M - S32 × 31,5**

5.2 The symbols given in Table 1 shall be used.

**Table 1 — Symbols for designation of flange type**

Style	Letter
2,5 to 35 MPa (25 bar to 350 bar)	L
40 MPa (400 bar)	S
Shape	Symbol
Straight	S
45° elbow, short	E45S
45° elbow, medium	E45M
90° elbow, short	ES
90° elbow, medium	EM
The following fitting angles are not preferred:	Symbol
22,5° elbow, medium	E22M
30° elbow, short	E30S
30° elbow, medium	E30M
60° elbow, short	E60S
60° elbow, medium	E60M
67,5° elbow, short	E67S
67,5° elbow, medium	E67M

## 6 Design

6.1 Hose fitting dimensions shown in Figures 2 to 8 shall conform to those given in Tables 2 to 8 and to the relevant dimensions in ISO 6162.

6.2 Angular tolerances on axes of ends of elbows shall be  $\pm 3^\circ$  for all sizes.

6.3 Details of contour shall be as chosen by the manufacturer, provided that the dimensions given in Tables 2 to 8 are maintained.

## 7 Manufacture

### 7.1 Construction

Fittings may be made by forging or cold forming, machined from barstock or manufactured from multiple components.

### 7.2 Workmanship

Workmanship shall conform to the best commercial practice to produce high quality fittings. Fittings shall be free from visual contaminants, all hanging burrs, loose scale and slivers which might be dislodged in use, and any other defects that might affect the function of the parts. All machined surfaces shall have a surface roughness value of  $Ra \leq 6,3 \mu\text{m}$ , except where otherwise specified.

### 7.3 Finish

The external surface and threads of all carbon steel parts shall be plated or coated with a suitable material that passes a 72 h neutral salt spray test in accordance with ISO 9227, unless otherwise agreed upon by the manufacturer and the user. Any appearance of red rust during the salt spray test on any area, except those noted below, shall be considered failure:

- all internal fluid passages;
- edges, such as hex points, serrations and crests of threads, where there may be mechanical deformation of the plating or coating typical of mass-produced parts or shipping effects;
- areas where there is mechanical deformation of the plating or coating caused by crimping, flaring, bending and other post-plate metal forming operations;
- areas where the parts are suspended or affixed in the test chamber where condensate can accumulate.

Internal fluid passages shall be protected from corrosion during storage.

NOTE Cadmium plating is not preferred due to environmental concerns. Changes in plating may affect assembly torques and require requalification, when applicable.

### 7.4 Fitting protection

By a method agreed between the supplier and purchaser, the face of the flange fittings shall be protected by the manufacturer from nicks and scratches that would be detrimental to the function of the fitting. Passages shall be securely covered to prevent the entrance of dirt or other contaminants.

## 8 Procurement information

ISO 12151-3:1999

<https://standards.iteh.ai/catalog/standards/sist/0bbce1aa-765e-4e23-a2a6-5657d9c66649-12151-3-1999>

The following minimum information should be supplied by the purchaser when making an inquiry or placing an order:

- description of fitting (using designation in accordance with clause 5);
- material of fitting (if other than carbon steel);
- hose type and size;
- fluid to be conveyed;
- working pressure;
- working temperature (ambient and of the fluid).

## 9 Marking

Hose fittings shall be permanently marked with the manufacturer's name or trademark.

## 10 Identification statement (Reference to this part of ISO 12151)

Use the following statement in test reports, catalogues and sales literature when electing to comply with ISO 12151-3:

“Flange hose fittings in accordance with ISO 12151-3:1999, *Connections for hydraulic fluid power and general use — Hose fittings — Part 3: Hose fittings with ISO 6162 flange ends.*”



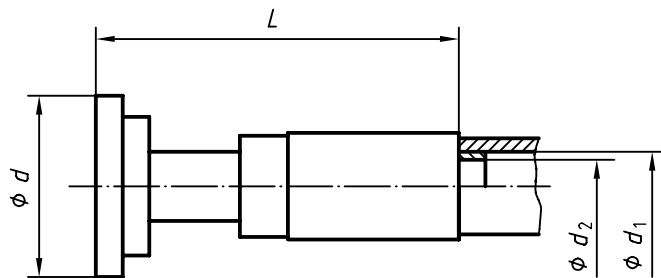

NOTE 1 Connection details and O-rings in accordance with ISO 6162.

NOTE 2 Method of attachment of fitting to hose is optional.

Figure 2 — Straight flange hose fittings (S)

**Table 2 — Dimensions of straight flange hose fittings (S)**  
(standards.iteh.ai)

Dimensions in millimetres

Fitting size	$d$ $\pm 0,25$		Nominal flange size	$d_1$ (nominal inside diameter of hose)	$d_2^a$ min.	$L^b$ max.
	S-L	S-S				
13 × 12,5	30,2	31,8	13	12,5	8	100
19 × 19	38,1	41,3	19	19	14	140
25 × 25	44,45	47,6	25	25	19	150
32 × 31,5	50,8	54	32	31,5	25	175
38 × 38	60,35	63,5	38	38	31	200
51 × 51	71,4	79,4	51	51	42	240

<sup>a</sup> Minimum diameter at any point through the fitting prior to assembly to the hose. The diameter after assembly shall not be less than  $0,9d_2$ .

<sup>b</sup> Dimension  $L$  is measured after assembly.