



SLOVENSKI STANDARD SIST EN 15184:2006

01-december-2006

Df c]nj cX]]b'g]ghYa]'nUnUý]lc]b'dcdfUj]c`VYfcbg_]' _cbgfi _VW^!'DfYg_i gbY
a YfcXY!'GhfjybUUX\ Ynj^UnUý]hYbY[U^Y`UdfcHj`VYfcbi `fbfYg_i g]nj`Y_Uk

Products and systems for the protection and repair of concrete structures - Test methods
- Shear adhesion of coated steel to concrete (pull-out test)

Produkte und Systeme für den Schutz und die Instandsetzung von Betontragwerken -
Prüfverfahren - Haftzugfestigkeit zwischen beschichtetem Stahl und Beton
(Ausziehversuch)

(standards.iteh.ai)

Produits et systemes de protection et de réparation des structures en béton - Méthodes
d'essai - Adhérence par cisaillement d'acier revêtu au béton (essai d'arrachement)

<https://standards.iteh.ai/catalog/standards/sist/db248766-11e-4aa0-9719-b0338486af70/sist-en-15184-2006>

Ta slovenski standard je istoveten z: EN 15184:2006

ICS:

91.080.40 Betonske konstrukcije Concrete structures

SIST EN 15184:2006 en

iTeh STANDARD PREVIEW
(standards.iteh.ai)

SIST EN 15184:2006

<https://standards.iteh.ai/catalog/standards/sist/db248768-ff1c-4aa0-9719-b0338486af70/sist-en-15184-2006>

ICS 91.080.40

English Version

Products and systems for the protection and repair of concrete structures - Test methods - Shear adhesion of coated steel to concrete (pull-out test)

Produits et systèmes pour la protection et la réparation des structures en béton - Méthodes d'essais - Adhérence par cisaillement d'acier revêtu au béton (essai d'arrachement)

Produkte und Systeme für den Schutz und die Instandsetzung von Betontragwerken - Prüfverfahren - Haftzugfestigkeit zwischen beschichtetem Stahl und Beton (Ausziehversuch)

This European Standard was approved by CEN on 1 August 2006.

CEN members are bound to comply with the CEN/CENELEC Internal Regulations which stipulate the conditions for giving this European Standard the status of a national standard without any alteration. Up-to-date lists and bibliographical references concerning such national standards may be obtained on application to the Central Secretariat or to any CEN member.

This European Standard exists in three official versions (English, French, German). A version in any other language made by translation under the responsibility of a CEN member into its own language and notified to the Central Secretariat has the same status as the official versions.

CEN members are the national standards bodies of Austria, Belgium, Cyprus, Czech Republic, Denmark, Estonia, Finland, France, Germany, Greece, Hungary, Iceland, Ireland, Italy, Latvia, Lithuania, Luxembourg, Malta, Netherlands, Norway, Poland, Portugal, Romania, Slovakia, Slovenia, Spain, Sweden, Switzerland and United Kingdom.



EUROPEAN COMMITTEE FOR STANDARDIZATION
COMITÉ EUROPÉEN DE NORMALISATION
EUROPÄISCHES KOMITEE FÜR NORMUNG

Management Centre: rue de Stassart, 36 B-1050 Brussels

Contents

Page

Foreword.....	3
1 Scope	4
2 Normative references	4
3 Terms and definitions	4
4 Test principle.....	4
5 Apparatus	5
6 Preparation of the test specimens	5
7 Execution of the bond test.....	8
8 Test report	10
Bibliography	11

iTeh STANDARD PREVIEW (standards.iteh.ai)

[SIST EN 15184:2006](https://standards.iteh.ai/catalog/standards/sist/db248768-ff1c-4aa0-9719-b0338486af70/sist-en-15184-2006)

<https://standards.iteh.ai/catalog/standards/sist/db248768-ff1c-4aa0-9719-b0338486af70/sist-en-15184-2006>

Foreword

This document (EN 15184:2006) has been prepared by Technical Committee CEN/TC 104 "Concrete and related products", the secretariat of which is held by DIN.

This European Standard shall be given the status of a national standard, either by publication of an identical text or by endorsement, at the latest by February 2007, and conflicting national standards shall be withdrawn at the latest by February 2007.

This European Standard is one of a series of test method standards on products and systems for protection and repair of concrete structures; particularly it describes a method of testing the shear adhesion of products applied to reinforcing bars.

According to the CEN/CENELEC Internal Regulations, the national standards organizations of the following countries are bound to implement this European Standard: Austria, Belgium, Cyprus, Czech Republic, Denmark, Estonia, Finland, France, Germany, Greece, Hungary, Iceland, Ireland, Italy, Latvia, Lithuania, Luxembourg, Malta, Netherlands, Norway, Poland, Portugal, Romania, Slovakia, Slovenia, Spain, Sweden, Switzerland and United Kingdom.

iTeh STANDARD PREVIEW (standards.iteh.ai)

SIST EN 15184:2006

<https://standards.iteh.ai/catalog/standards/sist/db248768-ff1c-4aa0-9719-b0338486af70/sist-en-15184-2006>

1 Scope

This European Standard specifies a method for determining the shear adhesion of steel rebar coated with a corrosion protection product or system and embedded in a standard reference concrete.

The test applies to products based on hydraulic binders or polymers or mixtures of both.

2 Normative references

The following referenced documents are indispensable for the application of this document. For dated references, only the edition cited applies. For undated references, the latest edition of the referenced document (including any amendments) applies.

EN 196-1, *Methods of testing cement — Determination of strength*

EN 1504-1:2005, *Products and systems for the protection and repair of concrete structures — Definitions requirements, quality control and evaluation of conformity — Part 1: Definitions*

EN 1504-7:2006, *Products and systems for the protection and repair of concrete structures — Definitions requirements, quality control and evaluation of conformity — Part 7: Reinforcement corrosion protection*

ENV 1504-9:1997, *Products and systems for the protection and repair of concrete structures — Definitions requirements, quality control and evaluation of conformity — Part 9: General principles for the use of products and systems*

EN 1766, *Products and systems for the protection and repair of concrete structures — Test methods — Reference concretes for testing*

EN 10080, *Steel for the reinforcement of concrete — Weldable reinforcing steel — General*

EN 12390-2, *Testing hardened concrete — Part 2: Making and curing specimens for strength tests*

EN ISO 12944-4, *Paints and varnishes — Corrosion protection of steel structures by protective paint systems — Part 4: Types of surface and surface preparation (ISO 12944-4:1998)*

3 Terms and definitions

For the purposes of this document, the terms and definitions given in EN 1504-1:2005, EN 1504-7:2006 and ENV 1504-9:1997 apply.

4 Test principle

The test compares the shear adhesion of bars coated with a corrosion protection product or system to that of uncoated bars embedded in a standard reference concrete.

The test is carried out using concrete specimens in which coated and uncoated rebars are embedded. A tensile load is applied to one end of the rebar and increased at a controlled rate until failure occurs. The applied force and resulting displacement are measured for each of the coated and uncoated rebars and the results compared.

5 Apparatus

- 5.1 Concrete mixer** in accordance with EN 196-1, or a forced action pan mixer.
- 5.2 Compaction tools** and equipment in accordance with EN 196-1.
- 5.3 Stirrer and brush** to mix and apply the coating product.
- 5.4 Moulds** for the preparation of cubes of dimensions 200 mm × 200 mm × 200 mm (see Figure 1).
- 5.5 Thermometer** accurate to within 1 °C.
- 5.6 Tensile testing apparatus** of adequate capacity, capable of measuring load to an accuracy of ± 2 %, and fitted with a load pacer to control the rate of load increase.
- 5.7 A measuring device**, interlocked with the rebar and one or more displacement sensors, capable of measuring relative movement between the anchored bar and a fixed reference point on the cube to an accuracy of ± 0,01 mm.

6 Preparation of the test specimens

6.1 Description of the test specimens

For each coating product, three coated bars and three uncoated bars, taken from the same batch of reinforcement, shall be tested. The test specimen shall be a concrete cube with the bar incorporated in its central axis (Figure 1).

The effective bond length of the bar shall be 5 times the diameter of the bar ($5 d_s$). The remainder of the bar shall be enclosed within a plastic sleeve so that the end of the bar is unrestrained. The bar extends from two opposite faces of the specimen. The tensile load shall be applied to the longer end, and the device for measuring the displacement between steel and concrete shall be set on the shorter end. The plastic sleeve shall fit around the bar with a 1 mm tolerance and the thickness shall not exceed 2 mm. The annulus between the sleeve and the steel bar shall be sealed at the end with a suitable non-setting sealant. (Care shall be taken not to contaminate the surface of the bar which shall be bonded in the concrete).

Test specimens shall be produced in a room or chamber maintained at the standard laboratory climate, (21 ± 2) °C and (60 ± 10) % RH.

6.2 Surface preparation of bars to be tested

For each coating product to be tested, six 16 mm diameter ribbed bars in accordance with EN 10080, (type S235) shall be tested, three uncoated and three coated. The bars shall be free from grease, and shall be blast cleaned to Sa 2 ½ according to EN ISO 12944-4, (or according to the manufacturer's instructions if different). The length of the bars is typically 550 mm, but may be varied if the apparatus requires.

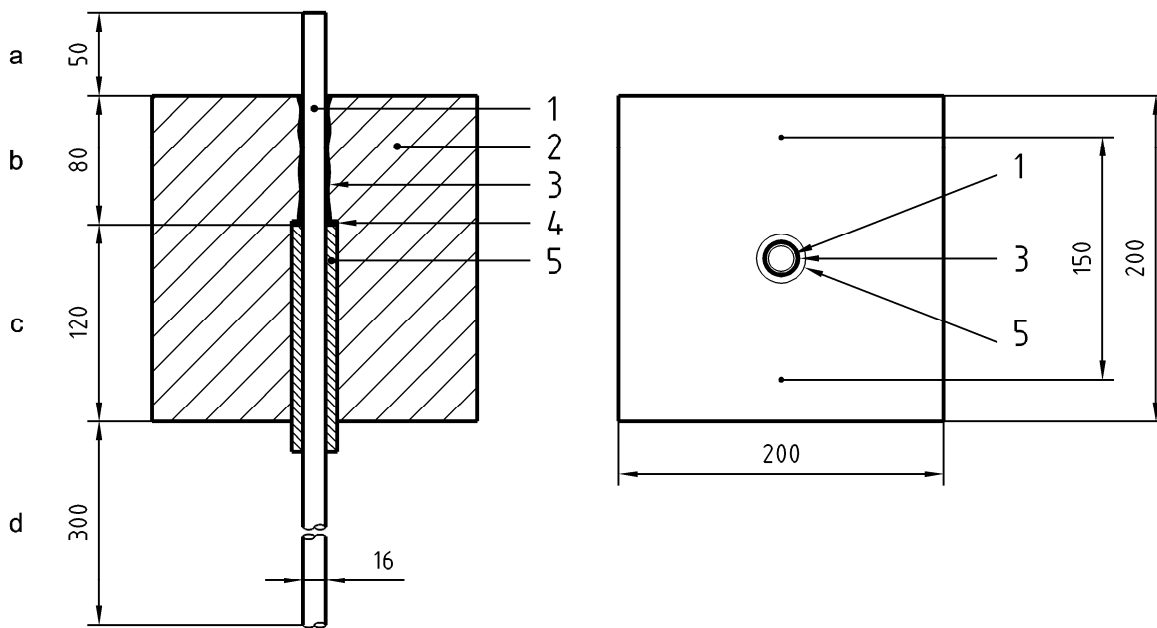

Key

- 1 – reinforcing bar (rebar)
- 2 – concrete
- 3 – steel coating
- 4 – seal between sleeve and bar
- 5 – plastic sleeve
- a – part of the bar up to the point of application of the displacement measuring device (50 mm)
- b – bond length (80 mm)
- c – free length (120 mm)
- d – part of the bar up to the point of application of the tension force (300 mm)

iTeh STANDARD PREVIEW
(standards.iteh.ai)

SIST EN 15184:2006

<https://standards.iteh.ai/catalog/standards/sist/db248768-f1c-4aa0-9719-b0338486af70/sist-en-15184-2006>

Figure 1 — Description and dimension of specimens (section and view from below)

6.3 Coating of bars

All materials shall be conditioned at the standard laboratory climate for a period of not less than 24 h prior to mixing.

The test bars shall be cleaned as specified in 6.2 immediately prior to coating. The coating product shall be mixed and applied at the standard laboratory climate in accordance with the manufacturer’s instructions. The coating shall be applied at the maximum thickness recommended by the manufacturer. After application the specimens shall be cured for 7 days (or as required by the manufacturer) under the standard laboratory climate.

The test bars shall be located in the mould as shown in Figure 2, with the plastic sleeve applied to the bar. The bars shall typically extend from the mould by 50 mm on one side and by 300 mm on the other side, sufficient to permit measurement and the application of tensile load (see Figure 1). The bar shall be located and supported along the centre line of the hole. The assembled mould containing the bar shall be placed in a room or chamber maintained at the standard laboratory climate prior to casting of the concrete specimens.

6.4 Casting of specimens

6.4.1 Composition of the concrete

The specimens shall be cast using type C (0,70) concrete in accordance with EN 1766.

6.4.2 Placing and compacting

The assembled moulds, equipment and tools required for mixing and placing shall be stored for at least 24 hours in a room or chamber maintained at laboratory standard climate.

The bar shall be kept in a horizontal position along the axis of the mould during placing and compaction of fresh concrete (Figure 2). Compaction shall be carried out as specified in EN 12390-2 to the same degree as for the cubes or cylinders used to determine the strength of concrete.

The concrete shall be placed in two layers of equal thickness and vibrated using a 25 mm diameter concrete vibrator. Each specimen shall be vibrated at four points, each position being equidistant from the two adjacent faces.

6.4.3 Storage of cast test specimens

The specimens shall be removed from the moulds 3 days after casting, during which time they shall be covered with wet cloths. After removal of the moulds, the specimens shall be stored at laboratory standard climate for 25 days.

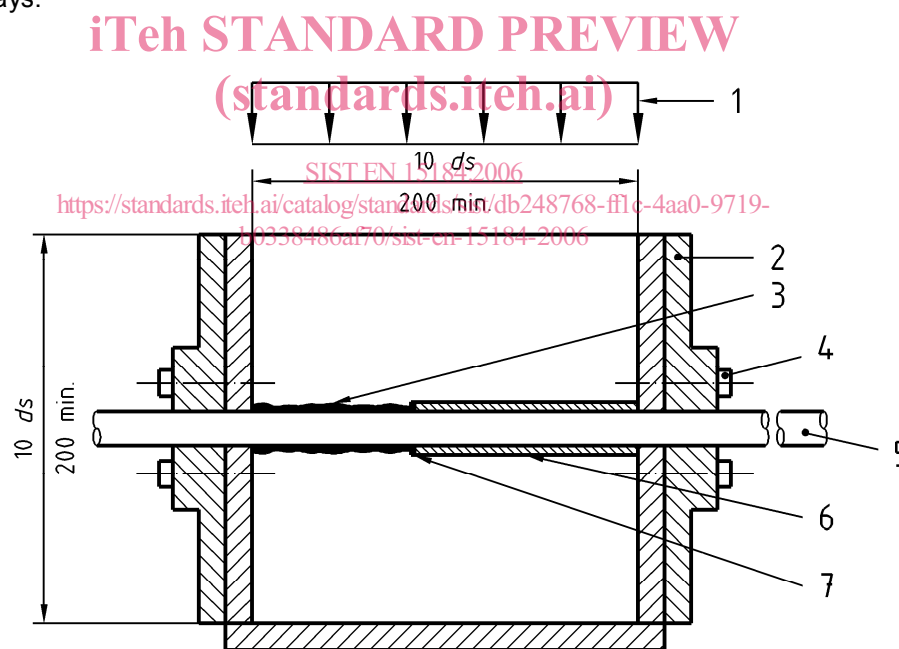

Key

- | | | | |
|---|-------------------------|---|------------------|
| 1 | direction of concreting | 5 | rebar |
| 2 | mould | 6 | plastic sleeve |
| 3 | steel coating | 7 | coating on steel |
| 4 | fixing element | | |

Figure 2 — Sketch of the mould (longitudinal section)