

---

---

**Road vehicles — Round, unscreened 60 V  
and 600 V multicore sheathed cables —  
Test methods and requirements for basic  
and high performance cables**

*Véhicules routiers — Câbles multiconducteurs sous gaine, ronds, non  
blindés de 60 V et 600 V — Méthodes d'essai et exigences pour les câbles  
à performances de base et à hautes performances*

**(standards.iteh.ai)**

[ISO 14572:2001](https://standards.iteh.ai/catalog/standards/sist/f6b724e4-0686-43f7-a6e3-20363f59ce49/iso-14572-2001)

[https://standards.iteh.ai/catalog/standards/sist/f6b724e4-0686-43f7-a6e3-  
20363f59ce49/iso-14572-2001](https://standards.iteh.ai/catalog/standards/sist/f6b724e4-0686-43f7-a6e3-20363f59ce49/iso-14572-2001)



**PDF disclaimer**

This PDF file may contain embedded typefaces. In accordance with Adobe's licensing policy, this file may be printed or viewed but shall not be edited unless the typefaces which are embedded are licensed to and installed on the computer performing the editing. In downloading this file, parties accept therein the responsibility of not infringing Adobe's licensing policy. The ISO Central Secretariat accepts no liability in this area.

Adobe is a trademark of Adobe Systems Incorporated.

Details of the software products used to create this PDF file can be found in the General Info relative to the file; the PDF-creation parameters were optimized for printing. Every care has been taken to ensure that the file is suitable for use by ISO member bodies. In the unlikely event that a problem relating to it is found, please inform the Central Secretariat at the address given below.

**iTeh STANDARD PREVIEW**  
**(standards.iteh.ai)**

ISO 14572:2001

<https://standards.iteh.ai/catalog/standards/sist/f6b724e4-0686-43f7-a6e3-20363f59ce49/iso-14572-2001>

© ISO 2001

All rights reserved. Unless otherwise specified, no part of this publication may be reproduced or utilized in any form or by any means, electronic or mechanical, including photocopying and microfilm, without permission in writing from either ISO at the address below or ISO's member body in the country of the requester.

ISO copyright office  
Case postale 56 • CH-1211 Geneva 20  
Tel. + 41 22 749 01 11  
Fax + 41 22 749 09 47  
E-mail [copyright@iso.ch](mailto:copyright@iso.ch)  
Web [www.iso.ch](http://www.iso.ch)

Printed in Switzerland

## Contents

	Page
Foreword.....	iv
1 Scope .....	1
2 Normative references .....	1
3 Terms and definitions .....	1
4 General.....	2
5 Dimensions .....	4
6 Electrical characteristics .....	5
7 Mechanical characteristics .....	5
8 Low temperature characteristics .....	8
9 Resistance to abrasion .....	9
10 Heat ageing .....	11
11 Chemical resistance .....	13
12 Resistance to flame propagation .....	14
13 Artificial weathering .....	14
Bibliography.....	15

[ISO 14572:2001](https://standards.iteh.ai/catalog/standards/sist/f6b724e4-0686-43f7-a6e3-20363f59ce49/iso-14572-2001)

<https://standards.iteh.ai/catalog/standards/sist/f6b724e4-0686-43f7-a6e3-20363f59ce49/iso-14572-2001>

## Foreword

ISO (the International Organization for Standardization) is a worldwide federation of national standards bodies (ISO member bodies). The work of preparing International Standards is normally carried out through ISO technical committees. Each member body interested in a subject for which a technical committee has been established has the right to be represented on that committee. International organizations, governmental and non-governmental, in liaison with ISO, also take part in the work. ISO collaborates closely with the International Electrotechnical Commission (IEC) on all matters of electrotechnical standardization.

International Standards are drafted in accordance with the rules given in the ISO/IEC Directives, Part 3.

The main task of technical committees is to prepare International Standards. Draft International Standards adopted by the technical committees are circulated to the member bodies for voting. Publication as an International Standard requires approval by at least 75 % of the member bodies casting a vote.

Attention is drawn to the possibility that some of the elements of this International Standard may be the subject of patent rights. ISO shall not be held responsible for identifying any or all such patent rights.

ISO 14572 was prepared by Technical Committee ISO/TC 22, *Road vehicles*, Subcommittee SC 3, *Electrical and electronic equipment*.

## iTeh STANDARD PREVIEW (standards.iteh.ai)

[ISO 14572:2001](https://standards.iteh.ai/catalog/standards/sist/f6b724e4-0686-43f7-a6e3-20363f59ce49/iso-14572-2001)

<https://standards.iteh.ai/catalog/standards/sist/f6b724e4-0686-43f7-a6e3-20363f59ce49/iso-14572-2001>

# Road vehicles — Round, unscreened 60 V and 600 V multicore sheathed cables — Test methods and requirements for basic and high performance cables

## 1 Scope

This International Standard specifies test methods and requirements for basic and high performance round, unscreened 60 V and 600 V multicore sheathed cables intended for use in road vehicle applications.

For the unscreened single-core cables used in the multicore cable, see ISO 6722. Other cores may be used, but with the construction and tests required to ensure functionality of these cores agreed between the customer and supplier.

For temperature classes, see ISO 6722.

## 2 Normative references

The following normative documents contain provisions which, through reference in this text, constitute provisions of this International Standard. For dated references, subsequent amendments to, or revisions of, any of these publications do not apply. However, parties to agreements based on this International Standard are encouraged to investigate the possibility of applying the most recent editions of the normative documents indicated below. For undated references, the latest edition of the normative document referred to applies. Members of ISO and IEC maintain registers of currently valid International Standards.

ISO 4892-2, *Plastics — Methods of exposure to laboratory light sources — Part 2: Xenon-arc sources*

ISO 6722<sup>1)</sup>, *Road vehicles — 60 V and 600 V single-core cables — Dimensions, test methods and requirements*

IEC 60811-1-1, *Common test methods for insulating and sheathing materials of electric cables — Part 1: Methods for general application — Section 1: Measurement of thickness and overall dimensions — Tests for determining the mechanical properties*

IEC 60811-1-2, *Common test methods for insulating and sheathing materials of electric cables — Part 1: Methods for general application — Section 2: Thermal ageing methods*

## 3 Terms and definitions

For the purposes of this International Standard, the terms and definitions given in ISO 6722 and the following apply.

### 3.1

#### **basic performance cable**

cable meeting basic requirements for general automotive applications

---

1) To be published.

**3.2**

**high performance cable**

cable meeting all basic requirements plus those of enhanced mechanical and/or environmental performance (as defined by the customer)

**3.3**

**screen**

conductive material intended to reduce the penetration and/or radiation of a varying electromagnetic field into an assigned region

**3.4**

**unscreened**

absence of a screen

**4 General**

**4.1 Voltage rating of cables**

The voltage rating is established by the rating of the cores. 60 V and 600 V cores shall not be mixed in the same multicore cable.

**4.2 600 V cables**

Special care shall be taken with cables used for voltages above 60 V DC in order to protect them from mechanical stress and avoid shock hazard.

The 600 V cable sheath shall be visually identified by permanent orange colouring.

**4.3 Tests**

ISO 14572:2001  
<https://standards.iteh.ai/catalog/standards/sist/f6b724e4-0686-43f7-a6e3-20363f59ce49/iso-14572-2001>

The cables shall be submitted to the tests specified in Table 1.

**4.4 General test conditions**

See ISO 6722.

**4.5 Ovens**

See ISO 6722.

**4.6 Visual appearance**

On visual examination, the sheath shall be smooth, even and free from surface imperfections such as lumps, voids, particles or other imperfections.

Table 1 — Tests

Clause	Test	In process test <sup>a</sup>	Certification		If required <sup>c</sup>	
			Initial	Periodic <sup>b</sup>	Initial	Periodic <sup>b</sup>
<b>4</b>	<b>General</b>					
4.6	Visual appearance		X	X		
<b>5</b>	<b>Dimensions</b>					
5.1	Outside cable diameter and ovality		X	X		
5.2	Thickness of sheath		X	X		
<b>6</b>	<b>Electrical characteristics</b>					
6.1	Continuity	X	X	X		
6.2	Withstand voltage	X	X	X		
<b>7</b>	<b>Mechanical characteristics</b>					
7.1	Pressure test at high temperature		X	X		
7.2	Adhesion of sheath				X	X
7.3	Cyclic bending				X	
<b>8</b>	<b>Low temperature characteristics</b>					
8.1	Winding		X	X		
8.2	Impact				X	X
<b>9</b>	<b>Resistance to abrasion</b>				X	X
<b>10</b>	<b>Heat ageing</b>					
10.1	Short-term ageing, 240 h		X	X		
10.2	Long-term ageing, 3 000 h		X	X		
10.3	Thermal overload				X	X
10.4	Shrinkage by heat of sheath		X	X		
<b>11</b>	<b>Chemical resistance</b>					
11.1	Fluid compatibility of sheath		d		d	
11.2	Durability of sheath marking				X	X
11.3	Resistance to ozone				X	
<b>12</b>	<b>Resistance to flame propagation</b>		X	X		
<b>13</b>	<b>Artificial weathering</b>				X	

<sup>a</sup> This is a test made of all cable during or after manufacture to check if it complies with the requirements of the standard concerned or the criteria specified.

<sup>b</sup> The frequency of periodic testing will be established by agreement between the customer and the supplier.

<sup>c</sup> The usage of "If required" tests will be established by agreement between customer and supplier.

<sup>d</sup> Some fluids are for "Certification" and others are "If required". See 11.1 for details.

## 5 Dimensions

### 5.1 Outside cable diameter and ovality

#### 5.1.1 Test sample

See ISO 6722.

#### 5.1.2 Apparatus

See ISO 6722.

#### 5.1.3 Procedure

See ISO 6722.

Determine for this test both the maximum ( $d_{\max}$ ) and the minimum ( $d_{\min}$ ) outside cable diameter. Then calculate the ovality, expressed as a percentage, as follows:

$$\text{ovality} = \frac{d_{\max} - d_{\min}}{0,5 (d_{\max} + d_{\min})} \times 100$$

#### 5.1.4 Requirement

Diameter and ovality shall be within the limits established by agreement between the customer and supplier.

iTeh STANDARD PREVIEW  
(standards.iteh.ai)

### 5.2 Thickness of sheath<sup>2)</sup>

ISO 14572:2001

#### 5.2.1 Test samples

<https://standards.iteh.ai/catalog/standards/sist/f6b724e4-0686-43f7-a6e3-20363f59ce49/iso-14572-2001>

See ISO 6722.

#### 5.2.2 Apparatus

See ISO 6722.

#### 5.2.3 Procedure

See ISO 6722.

#### 5.2.4 Requirement

The thickness of the sheath shall be within the limits established by agreement between the customer and supplier.

---

2) See ISO 6722, insulation thickness.



## 6 Electrical characteristics

### 6.1 Continuity

#### 6.1.1 Test sample

Remove 100 mm of sheath from each end of a complete cable and 25 mm of insulation from each end of the cores.

#### 6.1.2 Apparatus

Use an appropriate voltage source connected in series with an indicator such as an ohmmeter, light or buzzer.

#### 6.1.3 Procedure

Connect the apparatus to one of the cores. Repeat the procedure until all cores have been tested. As an alternative, all of the cores may be tested at once by connecting them in series. Take care to select a current which will not damage the individual conductors.

#### 6.1.4 Requirement

The indicator shall show continuity.

### 6.2 Withstand voltage

#### 6.2.1 Test sample

Remove 100 mm of sheath from one end of the cable and 25 mm of insulation from each core. For the test, connect the conductors of all the cores together at one end, except for the core being tested.

<https://standards.iteh.ai/catalog/standards/sist/f6b724e4-0686-43f7-a6e3-20363f59ce49/iso-14572-2001>

#### 6.2.2 Apparatus

Use a 50 Hz or 60 Hz voltage source capable of applying 1 kV (rms) for a minimum of 3 s.

#### 6.2.3 Procedure

Apply 1 kV (rms) between a core and the remaining cores for a minimum of 3 s. Repeat the procedure until all cores have been tested.

#### 6.2.4 Requirement

Breakdown shall not occur between cores.

## 7 Mechanical characteristics

### 7.1 Pressure test at high temperature

#### 7.1.1 Test samples

See ISO 6722.

**iTeh STANDARD PREVIEW**  
**(standards.iteh.ai)**

### 7.1.2 Apparatus

See ISO 6722. Apply the force  $F$  by the blade to the test sample as given by the formula:

$$F = 0,8\sqrt{i(2D - i)}$$

where

$F$  is the total vertical force exerted on the test sample, expressed in newtons;

0,8 is the coefficient that carries the dimension, expressed in newtons per millimetre;

$D$  is the maximum value of the outside diameter, expressed in millimetres (see 5.1);

$i$  is the specified minimum value of the sheath thickness, expressed in millimetres (see 5.2).

The calculated force may be rounded off at the lower digit, but not beyond 3 %.

### 7.1.3 Procedure

See ISO 6722. Measure the thickness of the sheath immediately, at the point of impression and at points 10 mm to both sides of the impression, by means of a measuring device that does not cause deformation. Omit the withstand voltage test.

### 7.1.4 Requirement

For basic performance cables, the thickness within the area of the impression shall be not less than 40 % of the mean of the other two values.

For high performance cables, the thickness within the area of the impression shall be not less than 60 % of the mean of the other two values.

## 7.2 Adhesion of sheath<sup>3)</sup>

### 7.2.1 General

The usage of this test will be established by agreement between customer and supplier.

### 7.2.2 Test sample

See ISO 6722. Prepare three test samples of 150 mm from a cable sample 3 m in length. The undisturbed length of sheath shall be 100 mm.

### 7.2.3 Apparatus

See ISO 6722. A metal plate is provided with a round hole equal to the approximate inside diameter of the sheath.

### 7.2.4 Procedure

See ISO 6722. If the 100 mm section of sheath buckles when sliding, prepare new test samples with the undisturbed length of sheath equal to 50 mm and repeat the procedure.

---

3) See ISO 6722, strip force.

### 7.2.5 Requirement

The undisturbed section of sheath shall be able to be removed without damage to the interior cores. The strip force shall be within the limits established by agreement between the customer and supplier.

## 7.3 Cyclic bending

### 7.3.1 General

The usage of this test will be established by agreement between customer and supplier.

### 7.3.2 Test samples

Take two test samples of 600 mm length from points of a cable separated by at least 1 m.

### 7.3.3 Apparatus

Use an apparatus that is in accordance with Figure 1, or equivalent.

The radius  $R$  shall be six ( ${}_{-20}^0\%$ ) times the outside cable diameter. A guide may be applied to stop the mass from swinging.

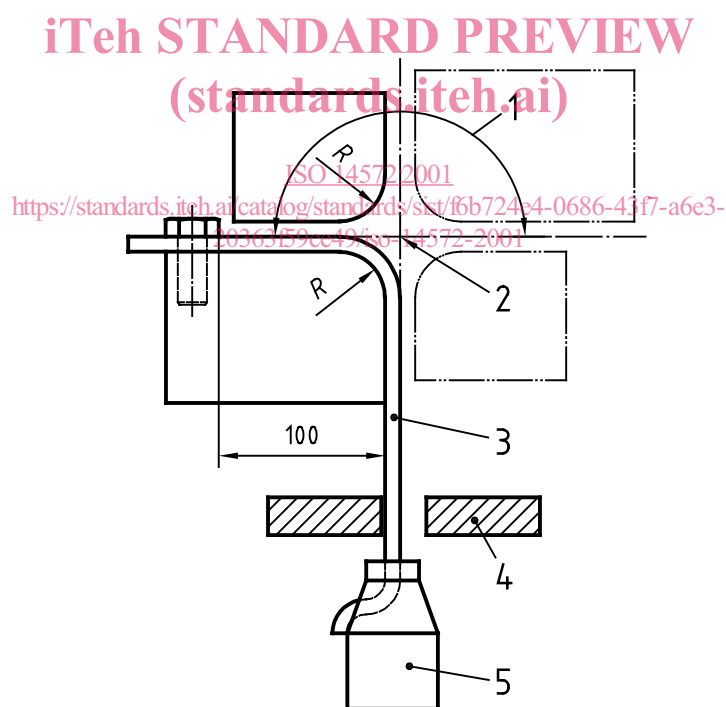

#### Key

- 1 1 cycle (90° to each side)
- 2 Pivot
- 3 Cable
- 4 Fixed guide (optional)
- 5 Mass

**Figure 1 — Apparatus for cyclic bending test**