



Designation: C 1275 – 00

# Standard Test Method for Monotonic Tensile Behavior of Continuous Fiber-Reinforced Advanced Ceramics with Solid Rectangular Cross-Section Test Specimens at Ambient Temperature<sup>1</sup>

This standard is issued under the fixed designation C 1275; the number immediately following the designation indicates the year of original adoption or, in the case of revision, the year of last revision. A number in parentheses indicates the year of last reapproval. A superscript epsilon ( $\epsilon$ ) indicates an editorial change since the last revision or reapproval.

## 1. Scope

1.1 This test method covers the determination of tensile behavior including tensile strength and stress-strain response under monotonic uniaxial loading of continuous fiber-reinforced advanced ceramics at ambient temperature. This test method addresses, but is not restricted to, various suggested test specimen geometries as listed in the appendix. In addition, specimen fabrication methods, testing modes (force, displacement, or strain control), testing rates (force rate, stress rate, displacement rate, or strain rate), allowable bending, and data collection and reporting procedures are addressed. Note that tensile strength as used in this test method refers to the tensile strength obtained under monotonic uniaxial loading where monotonic refers to a continuous nonstop test rate with no reversals from test initiation to final fracture.

1.2 This test method applies primarily to all advanced ceramic matrix composites with continuous fiber reinforcement: uni-directional (1-D), bi-directional (2-D), and tri-directional (3-D). In addition, this test method may also be used with glass (amorphous) matrix composites with 1-D, 2-D, and 3-D continuous fiber reinforcement. This test method does not address directly discontinuous fiber-reinforced, whisker-reinforced or particulate-reinforced ceramics, although the test methods detailed here may be equally applicable to these composites.

1.3 Values expressed in this test method are in accordance with the International System of Units (SI) and Practice E 380.

1.4 *This standard does not purport to address all of the safety concerns, if any, associated with its use. It is the responsibility of the user of this standard to establish appropriate safety and health practices and determine the applicability of regulatory limitations prior to use.* Specific hazard statements are given in Section 7 and Note 1.

<sup>1</sup> This practice is under the jurisdiction of ASTM Committee C-28 on Advanced Ceramics and is the direct responsibility of Subcommittee C28.07 on Ceramic Matrix Composites.

Current edition approved June 10, 2000. Published August 2000. Originally published as C 1275 – 94. Last previous edition C 1275 – 95.

## 2. Referenced Documents

### 2.1 *ASTM Standards:*

- C 1145 Terminology of Advanced Ceramics<sup>2</sup>
- C 1239 Practice for Reporting Uniaxial Strength Data and Estimating Weibull Distribution Parameters for Advanced Ceramics<sup>2</sup>
- D 3039/D3039M Test Method for Tensile Properties of Polymer Matrix Composite Materials<sup>3</sup>
- D 3379 Test Method for Tensile Strength and Young's Modulus for High-Modulus Single-Filament Materials<sup>3</sup>
- D 3878 Terminology of High-Modulus Reinforcing Fibers and Their Composites<sup>3</sup>
- E 4 Practices for Force Verification of Testing Machines<sup>4</sup>
- E 6 Terminology Relating to Methods of Mechanical Testing<sup>4</sup>
- E 83 Practice for Verification and Classification of Extensometers<sup>4</sup>
- E 177 Practice for Use of the Terms Precision and Bias in ASTM Test Methods<sup>5</sup>
- E 337 Test Method for Measuring Humidity with Psychrometer (the Measurement of Wet- and Dry-Bulb Temperatures)<sup>6</sup>
- E 380 Practice for Use of International System of Units (SI) (the Modernized Metric System)<sup>7</sup>
- E 691 Practice for Conducting an Interlaboratory Study to Determine the Precision of a Test Method<sup>5</sup>
- E 1012 Practice for Verification of Specimen Alignment Under Tensile Loading<sup>4</sup>

## 3. Terminology

3.1 *Definitions*—The definitions of terms relating to tensile testing appearing in Terminology E 6 apply to the terms used in this test method. The definitions of terms relating to advanced

<sup>2</sup> *Annual Book of ASTM Standards*, Vol 15.01.

<sup>3</sup> *Annual Book of ASTM Standards*, Vol 15.03.

<sup>4</sup> *Annual Book of ASTM Standards*, Vol 03.01.

<sup>5</sup> *Annual Book of ASTM Standards*, Vol 14.02.

<sup>6</sup> *Annual Book of ASTM Standards*, Vol 11.03.

<sup>7</sup> Discontinued 1997—Replaced by IEEE/ASTM SI-10.

ceramics appearing in Terminology C 1145 apply to the terms used in this test method. The definitions of terms relating to fiber reinforced composites appearing in Terminology D 3878 apply to the terms used in this test method. Pertinent definitions as listed in Practice E 1012, Terminology C 1145, Terminology D 3878, and Terminology E 6 are shown in the following with the appropriate source given in parentheses. Additional terms used in conjunction with this test method are defined in the following:

3.1.1 *advanced ceramic, n*—a highly engineered, high performance predominantly nonmetallic, inorganic, ceramic material having specific functional attributes. (See Terminology C 1145.)

3.1.2 *axial strain*—the average longitudinal strains measured at the surface on opposite sides of the longitudinal axis of symmetry of the specimen by two strain-sensing devices located at the mid length of the reduced section. (See Practice E 1012.)

3.1.3 *bending strain*—the difference between the strain at the surface and the axial strain. In general, the bending strain varies from point to point around and along the reduced section of the specimen. (See Practice E 1012.)

3.1.4 *breaking force*—the force at which fracture occurs. (See Terminology E 6.)

3.1.5 *ceramic matrix composite*—a material consisting of two or more materials (insoluble in one another), in which the major, continuous component (matrix component) is a ceramic, while the secondary component/s (reinforcing component) may be ceramic, glass-ceramic, glass, metal or organic in nature. These components are combined on a macroscale to form a useful engineering material possessing certain properties or behavior not possessed by the individual constituents.

3.1.6 *continuous fiber-reinforced ceramic matrix composite (CFCC)*—a ceramic matrix composite in which the reinforcing phase consists of a continuous fiber, continuous yarn, or a woven fabric.

3.1.7 *gage length*—the original length of that portion of the specimen over which strain or change of length is determined. (See Terminology E 6.)

3.1.8 *matrix-cracking stress*—the applied tensile stress at which the matrix cracks into a series of roughly parallel blocks normal to the tensile stress.

3.1.9 *Discussion*—In some cases, the matrix cracking stress may be indicated on the stress-strain curve by deviation from linearity (proportional limit) or incremental drops in the stress with increasing strain. In other cases, especially with materials which do not possess a linear portion of the stress-strain curve, the matrix cracking stress may be indicated as the first stress at which a permanent offset strain is detected in the unloading stress-strain (elastic limit).

3.1.10 *modulus of elasticity*—the ratio of stress to corresponding strain below the proportional limit. (See Terminology E 6.)

3.1.11 *modulus of resilience*—strain energy per unit volume required to elastically stress the material from zero to the proportional limit indicating the ability of the material to absorb energy when deformed elastically and return it when unloaded.

3.1.12 *modulus of toughness*—strain energy per unit volume required to stress the material from zero to final fracture indicating the ability of the material to absorb energy beyond the elastic range (that is, damage tolerance of the material).

3.1.13 *Discussion*—The modulus of toughness can also be referred to as the cumulative damage energy and as such is regarded as an indication of the ability of the material to sustain damage rather than as a material property. Fracture mechanics methods for the characterization of CFCCs have not been developed. The determination of the modulus of toughness as provided in this test method for the characterization of the cumulative damage process in CFCCs may become obsolete when fracture mechanics methods for CFCCs become available.

3.1.14 *proportional limit stress*—the greatest stress that a material is capable of sustaining without any deviation from proportionality of stress to strain (Hooke's law).

3.1.15 *Discussion*—Many experiments have shown that values observed for the proportional limit vary greatly with the sensitivity and accuracy of the testing equipment, eccentricity of loading, the scale to which the stress-strain diagram is plotted, and other factors. When determination of proportional limit is required, the procedure and sensitivity of the test equipment should be specified. (See Terminology E 6.)

3.1.16 *percent bending*—The bending strain times 100 divided by the axial strain. (See Practice E 1012.)

3.1.17 *slow crack growth*—subcritical crack growth (extension) which may result from, but is not restricted to, such mechanisms as environmentally-assisted stress corrosion or diffusive crack growth.

3.1.18 *tensile strength*—the maximum tensile stress which a material is capable of sustaining. Tensile strength is calculated from the maximum load during a tension test carried to rupture and the original cross-sectional area of the specimen. (See Terminology E 6.)

#### 4. Significance and Use

4.1 This test method may be used for material development, material comparison, quality assurance, characterization, and design data generation.

4.2 Continuous fiber-reinforced ceramic matrix composites generally characterized by fine grain sized (<50 μm) matrices and ceramic fiber reinforcements are candidate materials for structural applications requiring high degrees of wear and corrosion resistance, and high-temperature inherent damage tolerance (that is, toughness). In addition, continuous fiber-reinforced glass (amorphous) matrix composites are candidate materials for similar but possibly less-demanding applications. Although flexural test methods are commonly used to evaluate strengths of monolithic advanced ceramics, the non-uniform stress distribution of the flexure specimen in addition to dissimilar mechanical behavior in tension and compression for CFCCs lead to ambiguity of interpretation of strength results obtained from flexure tests for CFCCs. Uniaxial-loaded tensile strength tests provide information on mechanical behavior and strength for a uniformly-stressed material.

4.3 Unlike monolithic advanced ceramics which fracture catastrophically from a single dominant flaw, CFCCs generally experience “graceful” fracture from a cumulative damage

process. Therefore, the volume of material subjected to a uniform tensile stress for a single uniaxially-loaded tensile test may not be as significant a factor in determining the ultimate strengths of CFCCs. However, the need to test a statistically significant number of tensile specimens is not obviated. Therefore, because of the probabilistic nature of the strength distributions of the brittle matrices of CFCCs, a sufficient number of specimens at each testing condition is required for statistical analysis and design. Studies to determine the exact influence of specimen volume on strength distributions for CFCCs have not been completed. It should be noted that tensile strengths obtained using different recommended tensile specimens with different volumes of material in the gage sections may be different due to these volume differences.

4.4 Tensile tests provide information on the strength and deformation of materials under uniaxial tensile stresses. Uniform stress states are required to effectively evaluate any non-linear stress-strain behavior which may develop as the result of cumulative damage processes (for example, matrix cracking, matrix/fiber debonding, fiber fracture, delamination, etc.) which may be influenced by testing mode, testing rate, processing or alloying effects, or environmental influences. Some of these effects may be consequences of stress corrosion or subcritical (slow) crack growth that can be minimized by testing at sufficiently rapid rates as outlined in this test method.

4.5 The results of tensile tests of test specimens fabricated to standardized dimensions from a particular material or selected portions of a part, or both, may not totally represent the strength and deformation properties of the entire, full-size end product or its in-service behavior in different environments.

4.6 For quality control purposes, results derived from standardized tensile test specimens may be considered indicative of the response of the material from which they were taken for, given primary processing conditions and post-processing heat treatments.

4.7 The tensile behavior and strength of a CFCC are dependent on its inherent resistance to fracture, the presence of flaws, or damage accumulation processes, or both. Analysis of fracture surfaces and fractography, though beyond the scope of this test method, is highly recommended.

## 5. Interferences

5.1 Test environment (vacuum, inert gas, ambient air, etc.) including moisture content (for example, relative humidity) may have an influence on the measured tensile strength. In particular, the behavior of materials susceptible to slow crack growth fracture will be strongly influenced by test environment and testing rate. Testing to evaluate the maximum strength potential of a material should be conducted in inert environments or at sufficiently rapid testing rates, or both, so as to minimize slow crack growth effects. Conversely, testing can be conducted in environments and testing modes and rates representative of service conditions to evaluate material performance under use conditions. When testing is conducted in uncontrolled ambient air with the intent of evaluating maximum strength potential, relative humidity and temperature must be monitored and reported. Testing at humidity levels

>65 % relative humidity (RH) is not recommended and any deviations from this recommendation must be reported.

5.2 Surface preparation of test specimens, although normally not considered a major concern in CFCCs, can introduce fabrication flaws that may have pronounced effects on tensile mechanical properties and behavior (for example, shape and level of the resulting stress-strain curve, tensile strength and strain, proportional limit stress and strain, etc.). Machining damage introduced during specimen preparation can be either a random interfering factor in the determination of ultimate strength of pristine material (that is, increased frequency of surface initiated fractures compared to volume initiated fractures), or an inherent part of the strength characteristics to be measured. Surface preparation can also lead to the introduction of residual stresses. Universal or standardized test methods of surface preparation do not exist. It should be understood that final machining steps may, or may not negate machining damage introduced during the initial machining. Thus, specimen fabrication history may play an important role in the measured strength distributions and should be reported. In addition, the nature of fabrication used for certain composites (for example, chemical vapor infiltration or hot pressing) may require the testing of test specimens in the as-processed condition (that is, it may not be possible to machine the specimen faces).

5.3 Bending in uniaxial tensile tests can cause or promote non-uniform stress distributions with maximum stresses occurring at the specimen surface leading to non-representative fractures originating at surfaces or near geometrical transitions. In addition, if deformations or strains are measured at surfaces where maximum or minimum stresses occur, bending may introduce over or under measurement of strains depending on the location of the strain-measuring device on the specimen. Similarly, fracture from surface flaws may be accentuated or suppressed by the presence of the non-uniform stresses caused by bending.

5.4 Fractures that initiate outside the uniformly-stressed gage section of a test specimen may be due to factors such as stress concentrations or geometrical transitions, extraneous stresses introduced by gripping, or strength-limiting features in the microstructure of the specimen. Such non-gage section fractures will normally constitute invalid tests. In addition, for face-loaded geometries, gripping pressure is a key variable in the initiation of fracture. Insufficient pressure can shear the outer plies in laminated CFCCs; while too much pressure can cause local crushing of the CFCC and fracture in the vicinity of the grips.

## 6. Apparatus

6.1 *Testing Machines*—Machines used for tensile testing shall conform to the requirements of Practice E 4. The force used in determining tensile strength shall be accurate within  $\pm 1\%$  at any force within the selected force range of the testing machine as defined in Practice E 4. A schematic showing pertinent features of the tensile testing apparatus is shown in Fig. 1.

### 6.2 *Gripping Devices*:

6.2.1 *General*—Various types of gripping devices may be used to transmit the measured load applied by the testing



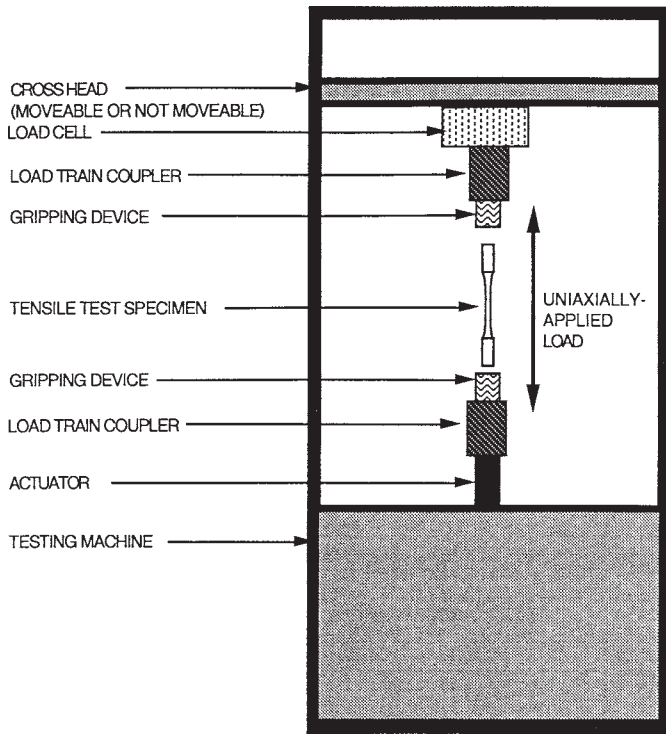

FIG. 1 Schematic Diagram of One Possible Apparatus for Conducting a Uniaxially-Loaded Tensile Test

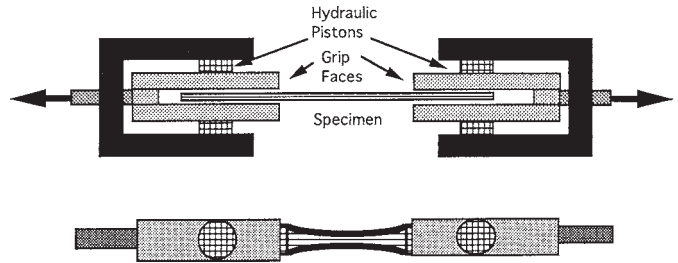

FIG. 2 Example of a Direct Lateral Pressure Grip Face for a Face-Loaded Grip Interface

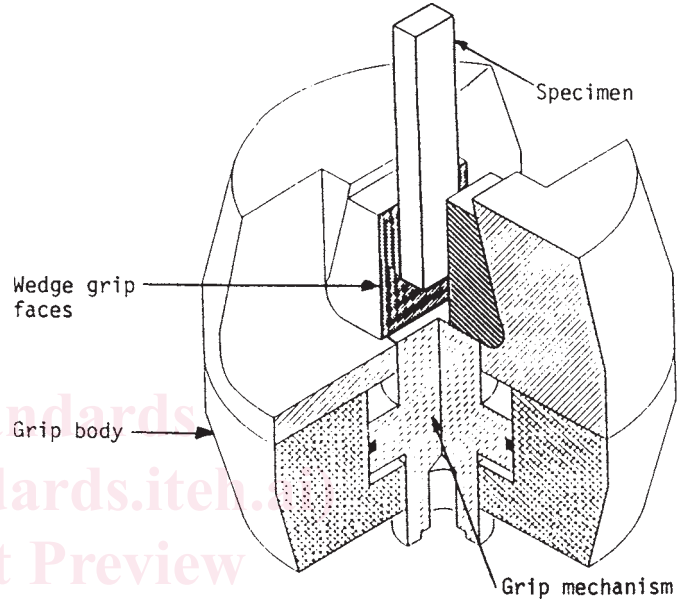

FIG. 3 Example of Indirect Wedge-Type Grip Faces for a Face-Loaded Grip Interface

machine to the test specimens. The brittle nature of the matrices of CFCCs requires a uniform interface between the grip components and the gripped section of the specimen. Line or point contacts and non-uniform pressure can produce Hertzian-type stresses leading to crack initiation and fracture of the test specimen in the gripped section. Gripping devices can be classed generally as those employing active and those employing passive grip interfaces as discussed in the following sections.

**6.2.2 Active Grip Interfaces**—Active grip interfaces require a continuous application of a mechanical, hydraulic, or pneumatic force to transmit the load applied by the test machine to the test specimen. Generally, these types of grip interfaces cause a force to be applied normal to the surface of the gripped section of the specimen. Transmission of the uniaxial force applied by the test machine is then accomplished by friction between the test specimen and the grip faces. Thus, important aspects of active grip interfaces are uniform contact between the gripped section of the test specimen and the grip faces and constant coefficient of friction over the grip/specimen interface.

**6.2.2.1** For flat test specimens, face-loaded grips, either by direct lateral pressure grip faces (1)<sup>8</sup> or by indirect wedge-type grip faces, act as the grip interface (2) as illustrated in Fig. 2 and Fig. 3, respectively. Generally, close tolerances are required for the flatness and parallelism as well as for the wedge angle of the wedge grip faces. In addition, the thickness, flatness, and parallelism of the gripped section of the specimen

must be within similarly close tolerances to promote uniform contact at the test specimen/grip interface. Tolerances will vary depending on the exact configuration as shown in the appropriate test specimen drawings.

**6.2.2.2** Sufficient lateral pressure must be applied to prevent slippage between the grip face and the specimen. Grip surfaces that are scored or serrated with a pattern similar to that of a single-cut file have been found satisfactory. A fine serration appears to be the most satisfactory. The serrations should be kept clean and well defined but not overly sharp. The length and width of the grip faces should be equal to or greater than the respective length and width of the gripped sections of the test specimen.

**6.2.3 Passive Grip Interfaces**—Passive grip interfaces transmit the force applied by the test machine to the test specimen through a direct mechanical link. Generally, these mechanical links transmit the test forces to the specimen via geometrical features of the test specimens such as shank shoulders or holes in the gripped head. Thus, the important aspect of passive grip interfaces is uniform contact between the gripped section of the test specimen and the grip faces.

**6.2.3.1** For flat test specimens, passive grips may act either through edge-loading via grip interfaces at the shoulders of the specimen shank (3) or by combinations of face-loading and pin

<sup>8</sup> The boldface numbers given in parentheses refer to a list of references at the end of the text.

loading via pins at holes in the gripped specimen head (4, 5). Generally, close tolerances of linear and angular dimensions of shoulder and grip interfaces are required to promote uniform contact along the entire test specimen/grip interface as well as to provide for non-eccentric loading as shown in Fig. 4. In addition, moderately close tolerances are required for center line coincidence and diameters of the pins and hole as indicated in Fig. 5.

6.2.3.2 When using edge-loaded specimen, lateral centering of the test specimen within the grip attachments is accomplished by use of wedge type inserts machined to fit within the grip cavity. In addition, wear of the grip cavity can be reduced by use of the thin brass sheets between the grip and test specimen without adversely affecting specimen alignment.

6.2.3.3 The pins in the face/pin loaded grip are primarily for alignment purposes with a secondary role of force transmission. Primary load transmission is through face-loading via mechanically actuated wedge grip faces. Proper tightening of the wedge grip faces against the test specimen to prevent slipping but avoid compressive fracture of the test specimen gripped section must be determined for each material and test specimen type.

6.2.3.4 Note that passive grips employing single pins in each gripped section of the test specimen as the primary force transfer mechanism are not recommended. Relatively low interfacial shear strengths compared to longitudinal tensile strengths in CFCCs (particularly for 1-D reinforced materials loaded along the fiber direction) may promote non-gage section fractures along interfaces particularly at geometric transitions or at discontinuities such as holes.

6.3 Load Train Couplers:

6.3.1 General—Various types of devices (load train couplers) may be used to attach the active or passive grip interface assemblies to the testing machine. The load train couplers in conjunction with the type of gripping device play major roles in the alignment of the load train and thus subsequent bending imposed in the specimen. Load train couplers can be classified generally as fixed and non-fixed as discussed in the following sections. Note that use of well-aligned fixed or self-aligning non-fixed couplers does not automatically guarantee low bending in the gage section of the tensile specimen. Generally, well-aligned fixed or self-aligning non-fixed couplers provide for well aligned load trains, but the type and operation of grip

interfaces as well as the as-fabricated dimensions of the tensile specimen can add significantly to the final bending imposed in the gage section of the specimen.

6.3.1.1 Regardless of which type of coupler is used, alignment of the testing system shall be verified at a minimum at the beginning and end of a test series unless the conditions for verifying alignment as detailed in X1.1 are otherwise met. A test series is interpreted to mean a discrete group of tests on individual specimens conducted within a discrete period of time on a particular material configuration, test specimen geometry, test conditions, or other uniquely definable qualifier (for example, a test series composed of material A comprising ten specimens of geometry B tested at a fixed rate in strain control to final fracture in ambient air). An additional verification of alignment is recommended, although not required, at the middle of the test series. Either a dummy or actual test specimen and the alignment verification procedures detailed in the appendix must be used. Allowable bending requirements are discussed in 6.5. Tensile specimens used for alignment verification should be equipped with a recommended eight separate longitudinal strain gages to determine bending contributions from both eccentric and angular misalignment of the grip heads. Ideally the verification specimen should be of identical material to that being tested. However, in the case of CFCCs, the type of reinforcement or degree of residual porosity may complicate the consistent and accurate measurement of strain. Therefore, an alternate material (isotropic, homogeneous, continuous) with elastic modulus, elastic strain capability, and hardness similar to the test material is recommended. In addition, dummy test specimens used for alignment verification, should have the same geometry and dimensions of the actual test specimens as well as similar mechanical properties as the test material to ensure similar axial and bending stiffness characteristics as the actual test specimen and material.

6.3.2 Fixed Load Train Couplers—Fixed couplers may incorporate devices that require either a one-time, pre-test alignment adjustment of the load train which remains constant for all subsequent tests or an in-situ, pre-test alignment of the load train that is conducted separately for each specimen and each test. Such devices (6, 7) usually employ angularity and concentricity adjusters to accommodate inherent load train misalignments. Regardless of which method is used, alignment verification must be performed as discussed in 6.3.1.1.

6.3.2.1 Fixed load train couplers are preferred in monotonic testing CFCCs because of the “graceful” fracture process in these materials. During this “graceful” fracture process, the fixed coupler tends to hold the test specimen in an aligned position, and thus, provides a continuous uniform stress across the remaining ligament of the gage section.

6.3.3 Non-Fixed Load Train Couplers—Non-fixed couplers may incorporate devices that promote self-alignment of the load train during the movement of the crosshead or actuator. Generally such devices rely upon freely moving linkages to eliminate applied moments as the load train components are loaded. Knife edges, universal joints, hydraulic couplers or air bearings are examples (4, 8, 9) of such devices. Examples of two such devices are shown in Fig. 6. Although non-fixed load

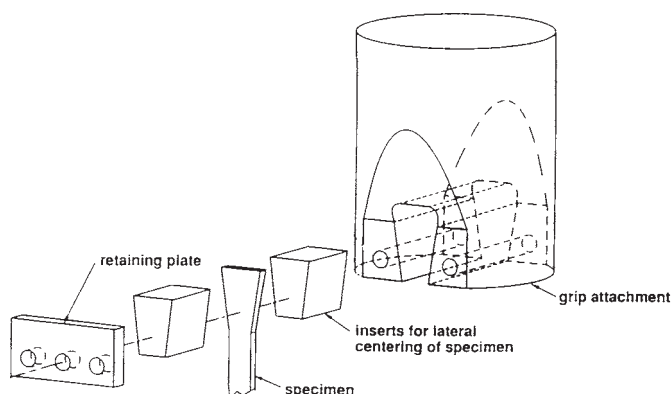

FIG. 4 Example of an Edge-Loaded, Passive Grip Interface (3)

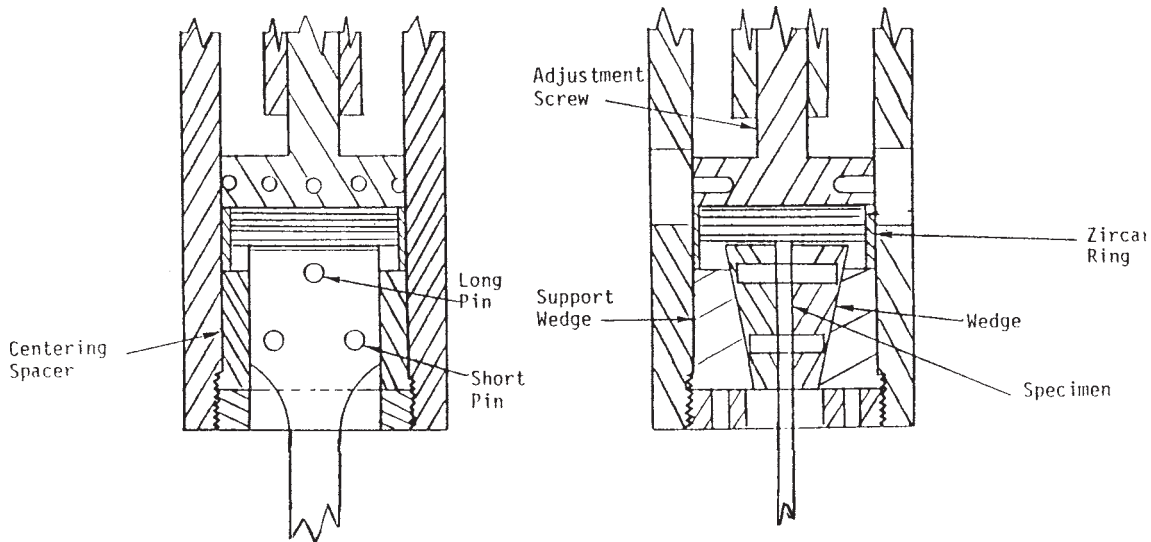

FIG. 5 Example of Pin/Face-Loaded Passive Grip Interface (4)

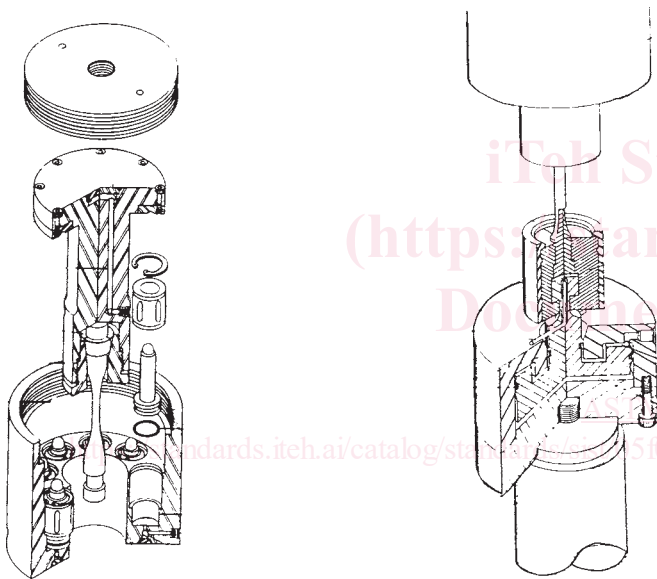

FIG. 6 Examples of Hydraulic, Self-Aligning, Non Fixed Load Train Couplers (8, 9)

train couplers are intended to be self-aligning and thus eliminate the need to evaluate the bending in the specimen for each test, the operation of the couplers must be verified as discussed in 6.3.1.1.

6.3.3.1 Non fixed load train couplers are useful in rapid test rate or constant load testing of CFCCs where the “graceful” fracture process is not as apparent. If the material exhibits “graceful” fracture the self aligning feature of the non-fixed coupler will allow rotation of the gripped section of the specimen thus promoting a non-uniform stress in the remaining ligament of the gage section.

6.4 *Strain Measurement*—Strain should be determined by means of either a suitable extensometer or strain gages. If Poisson’s ratio is to be determined, the test specimen must be instrumented to measure strain in both longitudinal and lateral directions.

6.4.1 Extensometers used for tensile testing of CFCC test specimens shall satisfy Test Method E 83, Class B-1 requirements and are recommended to be used in place of strain gages for test specimens with gage lengths of  $\geq 25$  mm and shall be used for high-performance tests beyond the range of strain gage applications. Extensometers shall be calibrated periodically in accordance with Test Method E 83. For extensometers mechanically attached to the specimen, the attachment should be such as to cause no damage to the specimen surface. In addition, the weight of the extensometer should be supported so as not to introduce bending greater than that allowed in 6.5.

6.4.2 Although not recommended for the actual testing, strain can also be determined directly from strain gages. If Poisson’s ratio is to be determined, the test specimen must be instrumented to measure strain in both longitudinal and lateral directions. Unless it can be shown that strain gage readings are not unduly influenced by localized strain events such as fiber crossovers, strain gages should not be less than 9 to 12 mm in length for the longitudinal direction and not less than 6 mm in length for the transverse direction. Note that larger strain gages than those recommended here may be required for fabric reinforcements to average the localized strain effects of the fiber crossovers. The strain gages, surface preparation, and bonding agents should be chosen to provide adequate performance on the subject materials and suitable strain recording equipment should be employed. Note that many CFCCs may exhibit high degrees of porosity and surface roughness and therefore require surface preparation including surface filling before the strain gages can be applied.

6.5 *Allowable Bending*—Analytical and empirical studies (10) have concluded that for negligible effects on the estimates of the strength distribution parameters (for example, Weibull modulus,  $\hat{m}$ , and characteristic strength,  $\hat{\sigma}_0$ ) of monolithic advanced ceramics, allowable percent bending as defined in Practice E 1012 should not exceed five. These conclusions (10) assume that tensile strength fractures are due to single fracture origins in the volume of the material, all tensile test specimens



experienced the same level of bending, and that Weibull modulus,  $\hat{m}$ , was constant.

6.5.1 Similar studies of the effect of bending on the tensile strength distributions of CFCCs do not exist. Until such information is forthcoming for CFCCs, this test method adopts the recommendations for tensile testing of monolithic advanced ceramics. Therefore, the recommended maximum allowable percent bending at the onset of the cumulative fracture process (for example, matrix cracking stress) for test specimens tested under this test method is five. However, it should be noted that unless all specimens are properly strain gaged and percent bending monitored until the onset of the cumulative fracture process, there will be no record of percent bending at the onset of fracture for each specimen. Therefore, the testing system shall be verified using the procedure detailed in the appendix such that percent bending does not exceed five at a mean strain equal to either one half the anticipated strain at the onset of the cumulative fracture process (for example, matrix cracking stress) or a strain of 0.0005 (that is, 500 microstrain) whichever is greater. This verification shall be conducted at a minimum at the beginning and end of each test series as recommended in 6.3.1.1. An additional verification of alignment is recommended, although not required, at the middle of the test series.

6.6 *Data Acquisition*—At the minimum, autographic record of applied load and gage section elongation or strain versus time should be obtained. Either analog chart recorders or digital data acquisition systems can be used for this purpose although a digital record is recommended for ease of later data analysis. Ideally, an analog chart recorder or plotter should be used in conjunction with the digital data acquisition system to provide an immediate record of the test as a supplement to the digital record. Recording devices shall be accurate to within  $\pm 0.1\%$  for the entire testing system including readout unit as specified in Practices E 4 and shall have a minimum data acquisition rate of 10 Hz with a response of 50 Hz deemed more than sufficient.

6.6.1 Strain or elongation of the gage section, or both, should be recorded either similarly to the force or as independent variables of force. Cross-head displacement of the test machine may also be recorded but should not be used to define displacement or strain in the gage section especially when self-aligning couplers are used in the load train.

6.7 *Dimension-Measuring Devices*—Micrometers and other devices used for measuring linear dimensions should be accurate and precise to at least one half the smallest unit to which the individual dimension is required to be measured. For the purposes of this test method, cross-sectional dimensions should be measured to within 0.02 mm requiring dimension measuring devices with accuracies of 0.01 mm.

## 7. Hazards

7.1 During the conduct of this test method, the possibility of flying fragments of broken test material is high. The brittle nature of advanced ceramics and the release of strain energy contribute to the potential release of uncontrolled fragments upon fracture. Means for containment and retention of these fragments for later fractographic reconstruction and analysis is highly recommended.

7.2 Exposed fibers at the edges of CFCC test specimens present a hazard due to the sharpness and brittleness of the ceramic fiber. All those required to handle these materials should be well informed of such conditions and the proper handling techniques.

## 8. Test Specimens

### 8.1 *Test Specimen Geometry*:

8.1.1 *General*—The geometry of tensile test specimen is dependent on the ultimate use of the tensile strength data. For example, if the tensile strength of an as-fabricated component is required, the dimensions of the resulting tensile specimen may reflect the thickness, width, and length restrictions of the component. If it is desired to evaluate the effects of interactions of various constituent materials for a particular CFCC manufactured via a particular processing route, then the size of the test specimen and resulting gage section will reflect the desired volume to be sampled. In addition, grip interfaces and load train couplers as discussed in Section will influence the final design of the test specimen geometry.

8.1.1.1 The following sections discuss the more common, and thus proven, of these tensile test specimen geometries although any geometry is acceptable if it meets the gripping, fracture location, and bending requirements of this test method. Deviations from the recommended geometries may be necessary depending upon the particular CFCC being evaluated. Stress analyses of untried test specimens should be conducted to ensure that stress concentrations that can lead to undesired fractures outside the gage sections do not exist. It should be noted that contoured specimens by their nature contain inherent stress concentrations due to geometric transitions. Stress analyses can indicate the magnitude of such stress concentrations while revealing the success of producing a uniform tensile stress state in the gage section of the test specimen.

8.1.1.2 Generally, specimens with contoured gage sections (transition radiuses of  $>50$  mm) are preferred to promote the tensile stresses with the greatest values in the uniformly-stressed gage section (II) while minimizing the stress concentration due to the geometrical transition of the radius. However, in certain instances, (for example, 1-D CFCCs tested along the direction of the fibers) low interfacial shear strength relative to the tensile strength in the fiber direction will cause splitting of the test specimen initiating at the transition region between the gage section and the gripped section of the test specimen with the split propagating along the fiber direction leading to fracture of the specimen. In these cases, straight-sided (that is, non-contoured) specimens as shown in Fig. 7, may be required for determining the tensile strength behavior of the CFCC. In other instances, a particular fiber weave or processing route will preclude fabrication of test specimens with reduced gage sections, thus requiring implementation of straight-sided specimens. Straight-sided test specimens may be gripped in any of the methods discussed here although active gripping systems are recommended for minimizing non-gage section fractures.

8.1.2 *Edge-Loaded Flat Tensile Test Specimens*—Fig. 8 and Fig. 9 show examples of edge-loaded test specimens which utilize the lateral compressive stresses developed at the test specimen/grip interface at the gripped section as the test specimen is pulled into the wedge of the grip. This type of

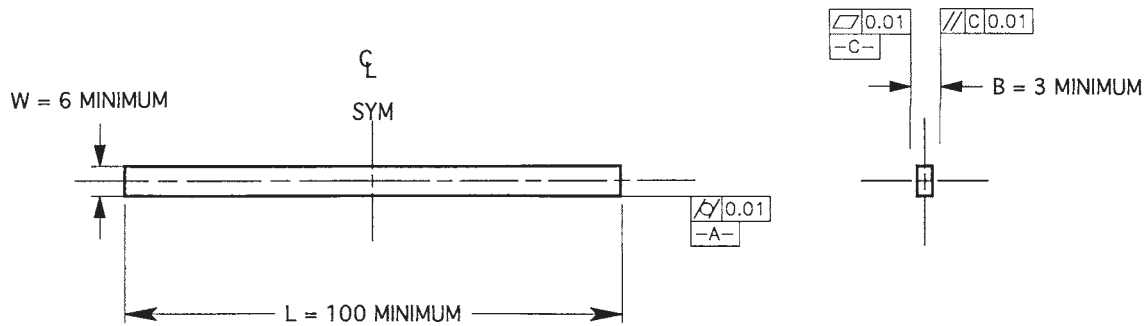

NOTE: 1) MINIMUM L = 100 mm WITH 25 mm GAGE SECTION. MINIMUM W = 6 mm.  
 2) SURFACE FINISH 0.5- 1.0  $\mu\text{m}$  ALL OVER EXCEPT END FACES WHICH MAY BE 1.0-2.0  $\mu\text{m}$ .  
 3) FINAL GRIND OF GAGE SECTION TO BE LONGITUDINAL

Tensile Specimen for CFCCs
mm X.X = 0.1, X.XX = 0.01, X.XXX = 0.001
SCALE: NTS

FIG. 7 Example of Straight-Sided Test Specimen Geometry

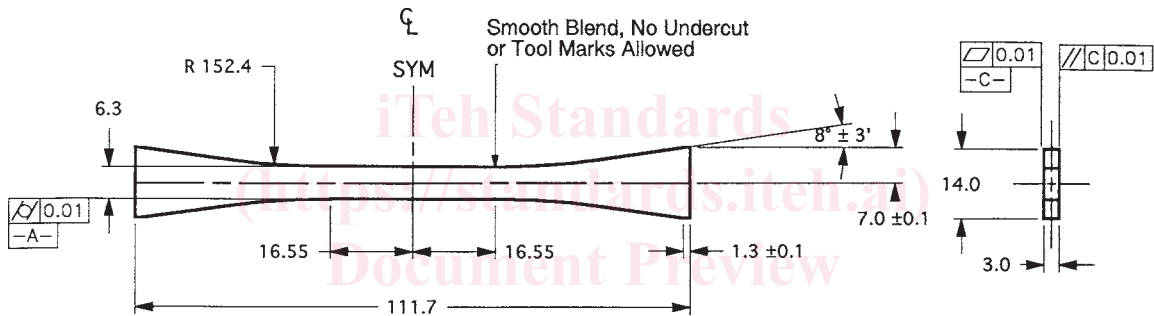

NOTE: 1) FINAL GRIND OF GAGE SECTION TO BE LONGITUDINAL

Tensile Specimen for CFCCs
mm X.X = 0.1, X.XX = 0.01, X.XXX = 0.001
SCALE: NTS

FIG. 8 Example of a Contoured, Edge-Loaded Test Specimen Geometry (3)

geometry has been successfully employed for the evaluation of 1-D, 2-D, and 3-D CFCCs. Of particular concern with this geometry is the proper and consistent angle of the edge loaded shank as shown in Fig. 8 and Fig. 9. Thus, the edge-loaded geometry may require somewhat intensive fabrication and inspection procedures.

8.1.3 *Face-Loaded Flat Tensile Test Specimens*—Fig. 10, Fig. 11, and Fig. 12 show examples of face-loaded specimens that exploit the friction at the test specimen/grip interface to transmit the uniaxial force applied by the test machine. Important tolerances for the face-loaded geometry include parallelism and flatness of faces all of which will vary depending on the exact configuration as shown in the appropriate specimen drawings.

8.1.3.1 For face-loaded specimens, especially for straight sided (that is, non-contoured) specimens, end tabs may be required to provide a compliant layer for gripping. Balanced 0/90° cross-ply tabs made from unidirectional non-woven E-glass have proven to be satisfactory for certain fiber-reinforced polymers (see Test Method D 3039). For CFCCs, fiber-glass reinforced epoxy, PMR, and carbon fiber-reinforced resin tab materials have been used successfully (11). However metallic tabs (for example, aluminum alloys) may be satisfactory as long as the tabs are strain compatible (having a similar elastic modulus as the CFCC) with the CFCC material being tested. Each beveled tab (bevel angle <15°) should be a minimum of 30 mm long, the same width of the specimen, and have the total thickness of the tabs on the order of the thickness



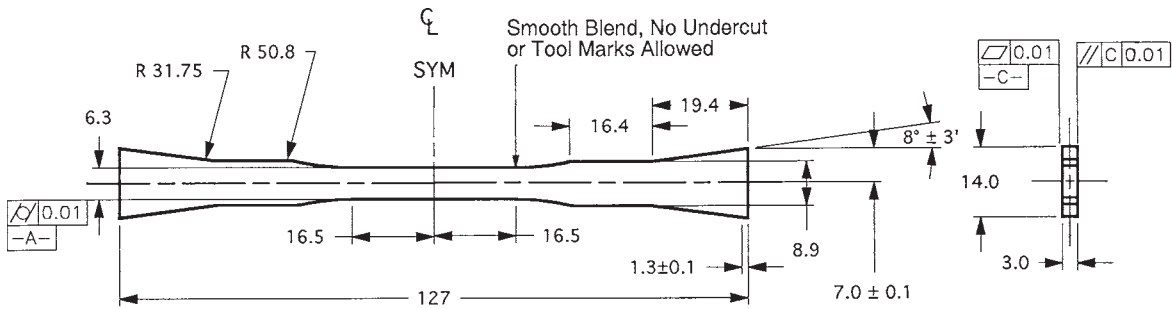

NOTE: 1) FINAL GRIND OF GAGE SECTION TO BE LONGITUDINAL

Tensile Specimen for CFCCs
mm X.X = 0.1, X.XX = 0.01, X.XXX = 0.001
SCALE: NTS

FIG. 9 Example of a Contoured, Edge-Loaded Test Specimen Geometry (3)

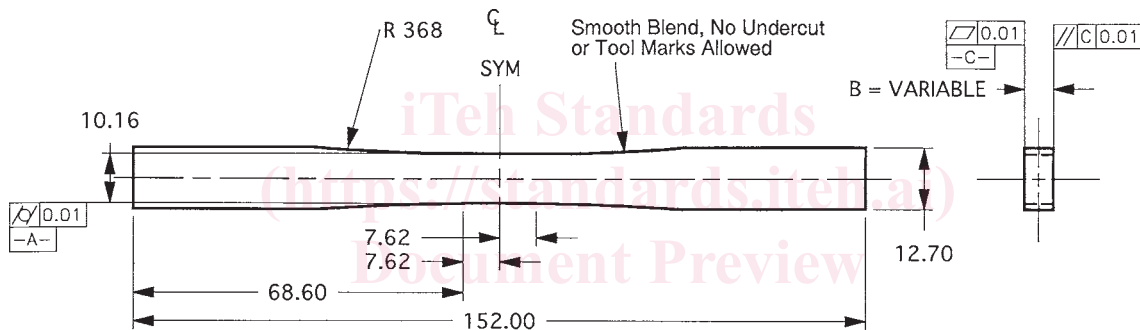

NOTE: 1) SURFACE FINISH 0.5- 1.0 μm ALL OVER EXCEPT END FACES WHICH MAY BE 1.0-2.0 μm.  
2) FINAL GRIND OF GAGE SECTION TO BE LONGITUDINAL

Tensile Specimen for CFCCs
mm X.X = 0.1, X.XX = 0.01, X.XXX = 0.001
SCALE: NTS

FIG. 10 Example of Contoured, Face-Loaded Test Specimen Geometry (11)

of the test specimen. Any high-elongation (tough) adhesive system may be used with the length of the tabs determined by the shear strength of the adhesive, size of the specimen, and estimated strength of the composite. In any case, a significant fraction ( $\geq 20\%$ ) of fractures within one test specimen width of the tab shall be cause to re-examine the tab materials and configuration, gripping method and adhesive, and to make necessary adjustments to promote fracture within the gage section. Fig. 13 shows an example of tab design which has been used successfully with CFCCs (11).

8.1.4 *Pin/Face-Loaded Flat Tensile Specimens*—The specimens shown in Figs. 14-16 employ combinations of pin and face loading to transmit the uniaxial force of the test machine to the specimen. Close tolerances of hole/pin diameters and center lines are required to ensure proper specimen alignment in the grips and transmission of the forces. The face-loaded part

of the geometry provides the primary load transmission mechanisms in these test specimens. Important tolerances for the face-loaded part of the geometry include parallelism and flatness of faces both of which will vary depending on the exact configuration as shown in the appropriate test specimen drawings. Thus the pin/face loaded geometry may require somewhat intensive fabrication procedures.

8.1.4.1 Note that test specimens requiring single pins in each gripped section of the specimen as the primary force transfer mechanism are not recommended. Relatively low interfacial shear strengths compared to longitudinal tensile strengths in CFCCs (particularly for 1-D reinforced materials loaded along the fiber direction) may promote non-gage section fractures along interfaces particularly at geometric transitions or at discontinuities such as holes.

8.2 *Specimen Preparation:*

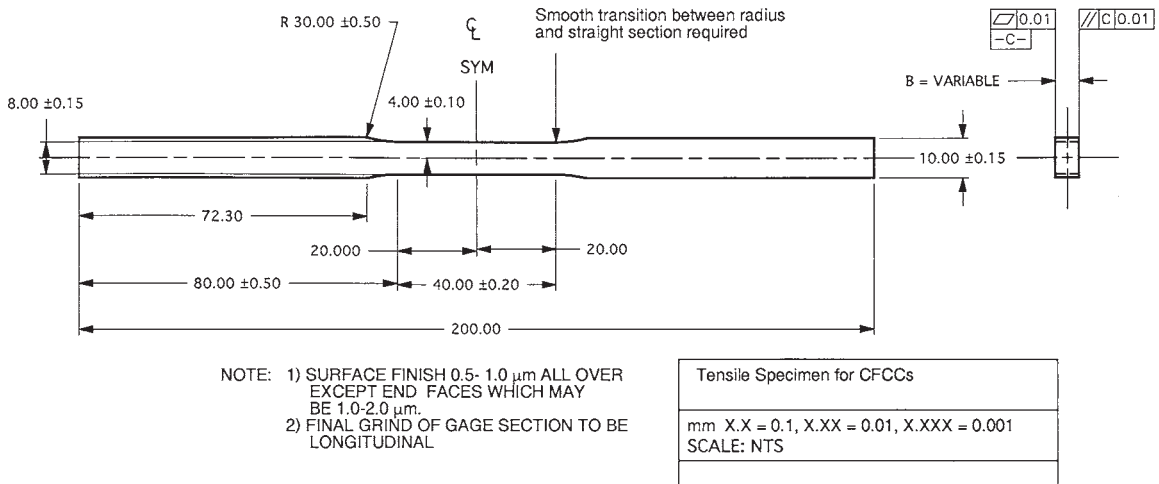

FIG. 11 Example of a Contoured, Face-Loaded Test Specimen Geometry

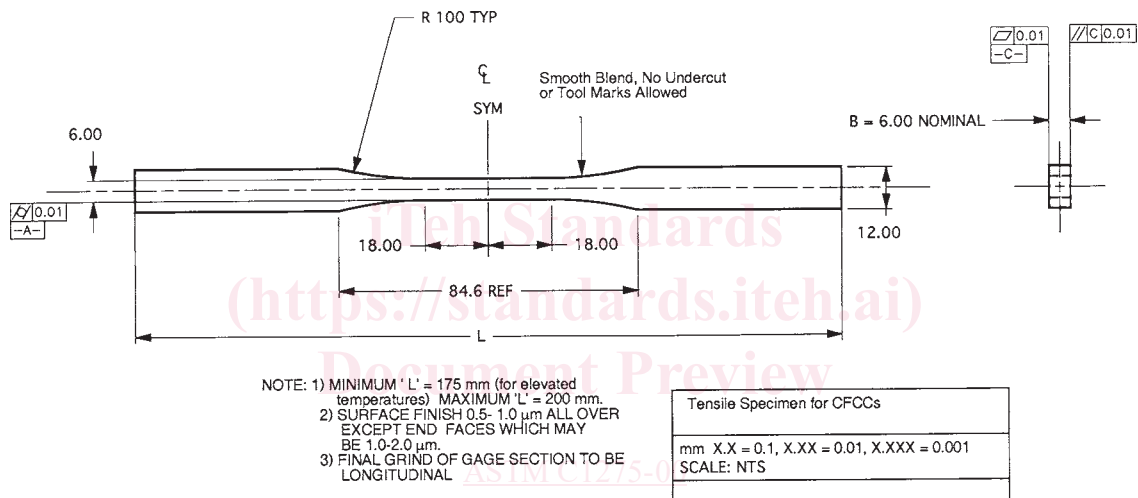

FIG. 12 Example of a Contoured, Face-Loaded Test Specimen Geometry

8.2.1 Depending upon the intended application of the tensile strength data, use one of the following specimen preparation procedures. Regardless of the preparation procedure used, sufficient details regarding the procedure must be reported to allow replication.

8.2.2 *As-Fabricated*—The tensile test specimen should simulate the surface/edge conditions and processing route of an application where no machining is used; for example, as-cast, sintered, or injection molded part. No additional machining specifications are relevant. As-processed test specimens might possess rough surface textures and nonparallel edges and as such may cause excessive misalignment or be prone to nongage section fractures, or both.

8.2.3 *Application-Matched Machining*— The tensile test specimen should have the same surface/edge preparation as that given to the component. Unless the process is proprietary, the report should be specific about the stages of material removal, wheel grits, wheel bonding, amount of material removed per pass, and type of coolant used.

8.2.4 *Customary Practices*—In instances where customary machining procedure has been developed that is completely satisfactory for a class of materials (that is, it induces no

unwanted surface/subsurface damage or residual stresses), this procedure should be used.

8.2.5 *Standard Procedure*—In instances where 8.2.2 through 8.2.4 are not appropriate, 8.2.5 should apply. Studies to evaluate the machinability of CFCCs have not been completed. Therefore, the standard procedure of 8.2.5 can be viewed as starting-point guidelines and a more stringent procedure may be necessary.

8.2.5.1 All grinding or cutting should be done with ample supply of appropriate filtered coolant to keep the workpiece and grinding wheel constantly flooded and particles flushed. Grinding can be done in at least two stages, ranging from coarse to fine rate of material removal. All cutting can be done in one stage appropriate for the depth of cut.

8.2.5.2 Stock removal rate should be on the order of 0.03 mm per pass using diamond tools that have between 320 and 600 grit. Remove equal stock from each face where applicable.

NOTE 1—**Caution:** Care should be exercised in storage and handling of finished test specimens to avoid the introduction of random and severe flaws. In addition, attention should be given to pre-test storage of test specimens in controlled environments or desiccators to avoid unquantifiable environmental degradation of specimens prior to testing.