**Plastics — Phenolic resins —
Determination of the gel time of resols
under specific conditions using automatic
apparatus**

*Plastiques — Résines phénoliques — Détermination du temps
de gélification des résols dans des conditions spécifiques sur appareils
automatiques*
(standards.iteh.ai)

[ISO 9396:1997](https://standards.iteh.ai/catalog/standards/sist/c618312d-6f15-4eca-adfd-697f2aaf0b4f/iso-9396-1997)

<https://standards.iteh.ai/catalog/standards/sist/c618312d-6f15-4eca-adfd-697f2aaf0b4f/iso-9396-1997>



Foreword

ISO (the International Organization for Standardization) is a worldwide federation of national standards bodies (ISO member bodies). The work of preparing International Standards is normally carried out through ISO technical committees. Each member body interested in a subject for which a technical committee has been established has the right to be represented on that committee. International organizations, governmental and non-governmental, in liaison with ISO, also take part in the work. ISO collaborates closely with the International Electrotechnical Commission (IEC) on all matters of electrotechnical standardization.

Draft International Standards adopted by the technical committees are circulated to the member bodies for voting. Publication as an International Standard requires approval by at least 75 % of the member bodies casting a vote.

International Standard ISO 9396 was prepared by Technical Committee ISO/TC 61, *Plastics*, Subcommittee SC 12, *Thermosetting materials*.

This second edition cancels and replaces the first edition (ISO 9396:1989), in which method A (which used a rotary stirrer) has been deleted and a precision clause added.

© ISO 1997

All rights reserved. Unless otherwise specified, no part of this publication may be reproduced or utilized in any form or by any means, electronic or mechanical, including photocopying and microfilm, without permission in writing from the publisher.

International Organization for Standardization
Case postale 56 • CH-1211 Genève 20 • Switzerland
Internet central@iso.ch
X.400 c=ch; a=400net; p=iso; o=isocs; s=central

Printed in Switzerland

Plastics — Phenolic resins — Determination of the gel time of resols under specific conditions using automatic apparatus

1. Scope

This International Standard specifies a method for determining the gel time of phenolic resins at a given temperature, using automatic apparatus under specified conditions. The test temperatures are 100 °C, 130 °C and 150 °C.

The method specified employs a plunger driven to carry out a reciprocating vertical motion.

This method applies to the following types of phenolic resin:

- liquid resols
- solid resols with low melting points

Powdered resins with a short gel time, such as mixtures of novolak and hexamethylenetetramine, do not lend themselves to this type of determination. Such resins crosslink as soon as fusion starts and become too viscous in the test tube to give meaningful results. Resins containing large amounts of a solvent with a low boiling point are especially unsuitable for this type of determination. With such resins, a boiling and distillation process takes place as the resin hardens.

It might be of interest to determine the time taken for the resin to gel in the presence of a catalyst. The catalyst shall be added in well defined proportions. The type of catalyst used and its treatment shall be stated in the test report.

2. Preparation of test portions

2.1 Test liquid resols as produced.

2.2 Test solid resols as produced.

3. Principle

A plunger placed in a test tube containing the substance to be examined is driven to carry out a reciprocating motion. The gel time is reached when the viscosity of the specimen is such that the tube is lifted with the plunger, thus stopping a timer.

4. Apparatus

- 4.1 **Automatic apparatus for measuring gel time** (see figure 1): The cycle time of the plunger shall be 10 s or as otherwise agreed between the parties concerned. The frequency shall be mentioned in the test report.
- 4.2 **Thermostatically controlled bath**, maximum temperature 200 °C, tolerance $\pm 0,5$ °C for the temperature chosen for the test (see 5). The density of the bath liquid, e.g. silicone oil, shall be $1 \text{ g/cm}^3 \pm 0,1 \text{ g/cm}^3$.
- 4.3 **Plunger**: metal wire with helix, length approx. 23 cm, diameter approx. 1 mm; helix at the end of the wire, height approx. 5 mm, diameter 5 mm to 6 mm.
- 4.4 **Test tube**, with a mass of $10 \text{ g} \pm 1 \text{ g}$ and the following dimensions: inside diameter $16 \text{ mm} \pm 0,2 \text{ mm}$, length $160 \text{ mm} \pm 4 \text{ mm}$.
- 4.5 **Metal ring**, weighing 10 g or 20 g, to hold down the test tube (4.4) in the bath (4.2).
- 4.6 **Balance**, accurate to 0,1 g.

iteh STANDARD PREVIEW
(standards.iteh.ai)

5. Procedure

Perform the test in duplicate, or on a greater number of test portions as agreed between the parties concerned.

Weigh $5 \text{ g} \pm 0,1 \text{ g}$ of resin into the test tube (4.4). Place the metal ring (4.5) round the top of the tube to hold it down in the bath (4.2) and to prevent it being lifted prematurely as the viscosity rises before the gel point is reached. The mass of the ring shall be

10 g for liquid resols

or

20 g for solid or powdered resols.

The test temperature shall be 100 °C, 130 °C or 150 °C, as agreed between the parties concerned.

Start up the apparatus (4.1) as soon as the test tube containing the resin to be tested is in its holder. In the case of liquid resins, connect up the plunger immediately. For solid resins, it will be necessary to wait until the resin has melted. During the test, the test tube shall remain immersed to a depth of 11 cm in the liquid in the thermostatically controlled bath, with part of the test tube holder also being immersed.

The gel time is reached, when the test tube follows the to-and-fro motion of the plunger, i.e. when the test tube starts to move in its holder. The apparatus will stop automatically when the gel time is reached.

6. Precision (test error)

6.1 Repeatability (r)

The value below which the absolute difference between two single test results, each the mean of duplicates, obtained on identical material by one operator in one laboratory within a short interval of time using the standardized test method, may be expected to lie with a 95 % probability is

2-8 % (depending on resin type)

6.2 Reproducibility (R)

The value below which the absolute difference between two test results, each the mean of duplicates, obtained on identical materials by operators in different laboratories using the standardized test method, may be expected to lie with a 95 % probability is

20 %

[ISO 9396:1997](https://standards.iteh.ai/catalog/standards/sist/c618312d-6f15-4eca-adfd-697f2aa10b4f/iso-9396-1997)

<https://standards.iteh.ai/catalog/standards/sist/c618312d-6f15-4eca-adfd-697f2aa10b4f/iso-9396-1997>

7. Test report

The test report shall contain the following information:

- a) a reference to this International Standard;
- b) all details necessary for the complete identification of the sample of resin tested;
- c) the arithmetic mean of the individual values measured for the gel time, expressed in minutes to the nearest 0,1 min.
- d) the temperature at which the test was performed;
- e) the frequency of the plunger motion.

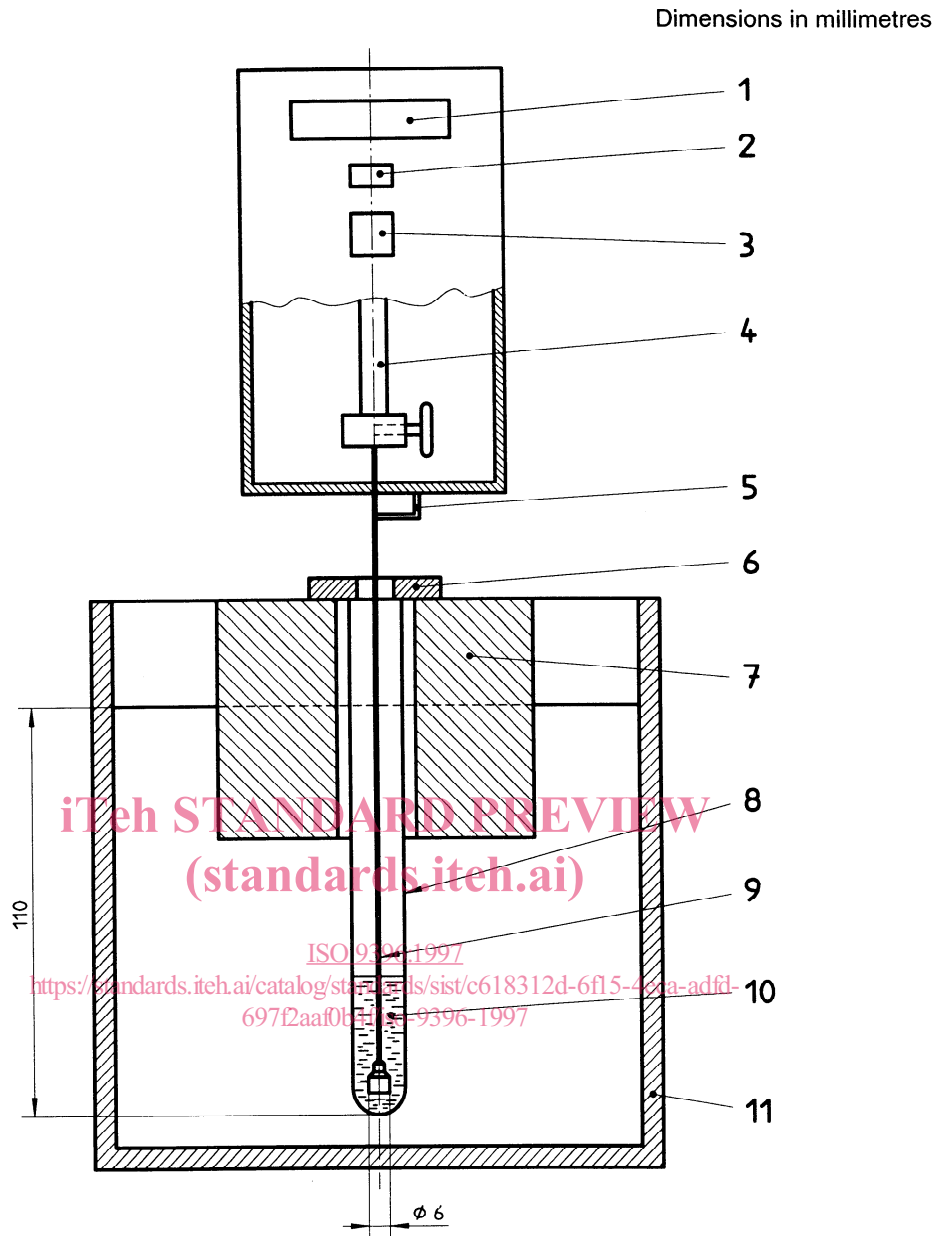

Key

- 1 Electric timer
- 2 Timer setting button
- 3 Start button for plunger and timer
- 4 Plunger drive motor
- 5 Stop lever for plunger and timer
- 6 Metal ring
- 7 Test tube holder
- 8 Test tube
- 9 Plunger (of material other than aluminium)
- 10 Phenolic resin
- 11 Thermostatically controlled bath containing a liquid suitable for use at the highest temperature employed

Figure 1 — Reciprocating-plunger apparatus for determining gel time

iTeh STANDARD PREVIEW
This page intentionally left blank
(standards.iteh.ai)

ISO 9396:1997

<https://standards.iteh.ai/catalog/standards/sist/c618312d-6f15-4eca-adfd-697f2aaf0b4f/iso-9396-1997>

iTeh STANDARD PREVIEW
(standards.iteh.ai)

ISO 9396:1997

<https://standards.iteh.ai/catalog/standards/sist/c618312d-6f15-4eca-adfd-697f2aaf0b4f/iso-9396-1997>

ICS 83.080.10

Descriptors: plastics, thermosetting resins, phenoplasts, tests, determination, gelation, time, test equipment.

Price based on 4 pages
