

INTERNATIONAL  
STANDARD

**ISO**  
**294-1**

First edition  
1996-12-15

---

---

**Plastics — Injection moulding of test  
specimens of thermoplastic materials —**

**Part 1:**  
General principles, and moulding of  
multipurpose and bar test specimens

[ISO 294-1:1996](https://standards.iteh.ai/catalog/standards/sist/58974be9-8d4c-4dbe-b998-520c06ff0ce9/iso-294-1-1996)

[https://standards.iteh.ai/catalog/standards/sist/58974be9-8d4c-4dbe-b998-](https://standards.iteh.ai/catalog/standards/sist/58974be9-8d4c-4dbe-b998-520c06ff0ce9/iso-294-1-1996)

[520c06ff0ce9/iso-294-1-1996](https://standards.iteh.ai/catalog/standards/sist/58974be9-8d4c-4dbe-b998-520c06ff0ce9/iso-294-1-1996)

*Plastiques — Moulage par injection des éprouvettes de matériaux  
thermoplastiques —*

*Partie 1: Principes généraux, et moulage des éprouvettes à usages  
multiples et des barreaux*



Reference number  
ISO 294-1:1996(E)

## Foreword

ISO (the International Organization for Standardization) is a worldwide federation of national standards bodies (ISO member bodies). The work of preparing International Standards is normally carried out through ISO technical committees. Each member body interested in a subject for which a technical committee has been established has the right to be represented on that committee. International organizations, governmental and non-governmental, in liaison with ISO, also take part in the work. ISO collaborates closely with the International Electrotechnical Commission (IEC) on all matters of electrotechnical standardization.

Draft International Standards adopted by the technical committees are circulated to the member bodies for voting. Publication as an International Standard requires approval by at least 75 % of the member bodies casting a vote.

International Standard ISO 294-1 was prepared by Technical Committee ISO/TC 61, *Plastics*, Subcommittee SC 9, *Thermoplastic materials*.

Together with the other parts, this part of ISO 294 cancels and replaces the second edition of ISO 294 (ISO 294:1995) which has been revised to improve the definition of the injection-moulding parameters and has been restructured to specify four types of ISO mould for the production of the basic specimen types required for the acquisition of comparable test data.

Care has been taken to ensure that the ISO moulds described can all be fitted in existing injection-moulding equipment and have interchangeable cavity plates.

ISO 294 consists of the following parts, under the general title *Plastics — Injection moulding of test specimens of thermoplastic materials*:

- *Part 1: General principles, and moulding of multipurpose and bar test specimens*
- *Part 2: Small tensile bars*
- *Part 3: Small plates*
- *Part 4: Determination of moulding shrinkage*

Annexes A to C of this part of ISO 294 are for information only.

© ISO 1996

All rights reserved. Unless otherwise specified, no part of this publication may be reproduced or utilized in any form or by any means, electronic or mechanical, including photocopying and microfilm, without permission in writing from the publisher.

International Organization for Standardization  
Case Postale 56 • CH-1211 Genève 20 • Switzerland

Printed in Switzerland

## Introduction

Many factors in the injection-moulding process may influence the properties of moulded test specimens and hence the measured values obtained when the specimens are used in a test method. The mechanical properties of such specimens are in fact strongly dependent on the conditions of the moulding process used to prepare the specimens. Exact definition of each of the main parameters of the moulding process is a basic requirement for reproducible and comparable operating conditions.

It is important in defining moulding conditions to consider any influence the conditions may have on the properties to be determined. Thermoplastics may show differences in molecular orientation (important mainly with amorphous polymers), in crystallization morphology (for crystalline and semicrystalline polymers), in phase morphology (for heterogeneous thermoplastics) as well as in the orientation of anisotropic fillers such as short fibres. Residual ("frozen-in") stresses in the moulded test specimens and thermal degradation of the polymer during moulding may also influence properties. Each of these phenomena must be controlled to avoid fluctuation of the numerical values of the properties measured.

<https://standards.iteh.ai/catalog/standards/sist/58974be9-8d4c-4dbe-b998-520c06ff0ce9/iso-294-1-1996>

**iTeh STANDARD PREVIEW**  
This page intentionally left blank  
**(standards.iteh.ai)**

ISO 294-1:1996

<https://standards.iteh.ai/catalog/standards/sist/58974be9-8d4c-4dbe-b998-520c06ff0ce9/iso-294-1-1996>

# Plastics — Injection moulding of test specimens of thermoplastic materials —

## Part 1:

General principles, and moulding of multipurpose and bar test specimens

### 1 Scope

This part of ISO 294 specifies the general principles to be followed when injection moulding test specimens of thermoplastic materials and gives details of mould designs for preparing two types of specimen for use in acquiring reference data, i.e. multipurpose test specimens as specified in ISO 3167 and 80 mm × 10 mm × 4 mm bars. It provides a basis for establishing reproducible moulding conditions. Its purpose is to promote uniformity in describing the main parameters of the moulding process and also to establish uniform practice in reporting moulding conditions. The particular conditions required for the reproducible preparation of test specimens which will give comparable results will vary for each material used. These conditions are given in the International Standard for the relevant material or are to be agreed upon between the interested parties.

NOTE — ISO round-robin tests with acrylonitrile/butadiene/styrene (ABS), styrene/butadiene (SB) and poly(methyl methacrylate) (PMMA) have shown that mould design is an important factor in the reproducible preparation of test specimens.

### 2 Normative references

The following standards contain provisions which, through reference in this text, constitute provisions of this part of ISO 294. At the time of publication, the editions indicated were valid. All standards are subject to revision, and parties to agreements based on this part of ISO 294 are encouraged to investigate the possibility of applying the most recent editions of the standards indicated below. Members of IEC and ISO maintain registers of currently valid International Standards.

ISO 179:1993, *Plastics — Determination of Charpy impact strength.*

ISO 294-2:1996, *Plastics — Injection moulding of test specimens of thermoplastic materials — Part 2: Small tensile bars.*

ISO 294-3:1996, *Plastics — Injection moulding of test specimens of thermoplastic materials — Part 3: Small plates.*

ISO 294-4:—<sup>1)</sup>, *Plastics — Injection moulding of test specimens of thermoplastic materials — Part 4: Determination of moulding shrinkage.*

1) To be published. (Revision in part of ISO 294:1995)

ISO 3167:1993, *Plastics — Multipurpose test specimens*.

ISO 10350:1993, *Plastics — Acquisition and presentation of comparable single-point data*.

ISO 11403-1:1994, *Plastics — Acquisition and presentation of comparable multipoint data — Part 1: Mechanical properties*.

ISO 11403-2:1995, *Plastics — Acquisition and presentation of comparable multipoint data — Part 2: Thermal and processing properties*.

ISO 11403-3:—<sup>2)</sup>, *Plastics — Acquisition and presentation of comparable multipoint data — Part 3: Environmental influences on properties*.

### 3 Definitions

For the purposes of the various parts of ISO 294, the following definitions apply.

**3.1 mould temperature,  $T_C$ :** The average temperature of the mould cavity surfaces measured after the system has attained thermal equilibrium and immediately after opening the mould (see 4.2.5 and 5.3).

It is expressed in degrees Celsius (°C).

**3.2 melt temperature,  $T_M$ :** The temperature of the molten plastic in a free shot (see 4.2.5 and 5.4).

It is expressed in degrees Celsius (°C).

**3.3 melt pressure,  $p$ :** The pressure of the plastic material in front of the screw at any time during the moulding process (see figure 1).

It is expressed in megapascals (MPa).

The melt pressure, which is generated hydraulically for instance, can be calculated from the force  $F_S$  acting longitudinally on the screw using equation (1):

$$p = \frac{4 \times 10^3 F_S}{\pi D^2} \quad \dots (1)$$

where

$p$  is the melt pressure, in megapascals;

$F_S$  is the longitudinal force, in kilonewtons, acting upon the screw;

$D$  is the screw diameter, in millimetres.

**3.4 hold pressure,  $p_H$ :** The melt pressure (see 3.3) during the hold time (see figure 1).

It is expressed in megapascals (MPa).

**3.5 moulding cycle:** The complete sequence of operations in the moulding process required for the production of one set of test specimens (see figure 1).

<sup>2)</sup> To be published.

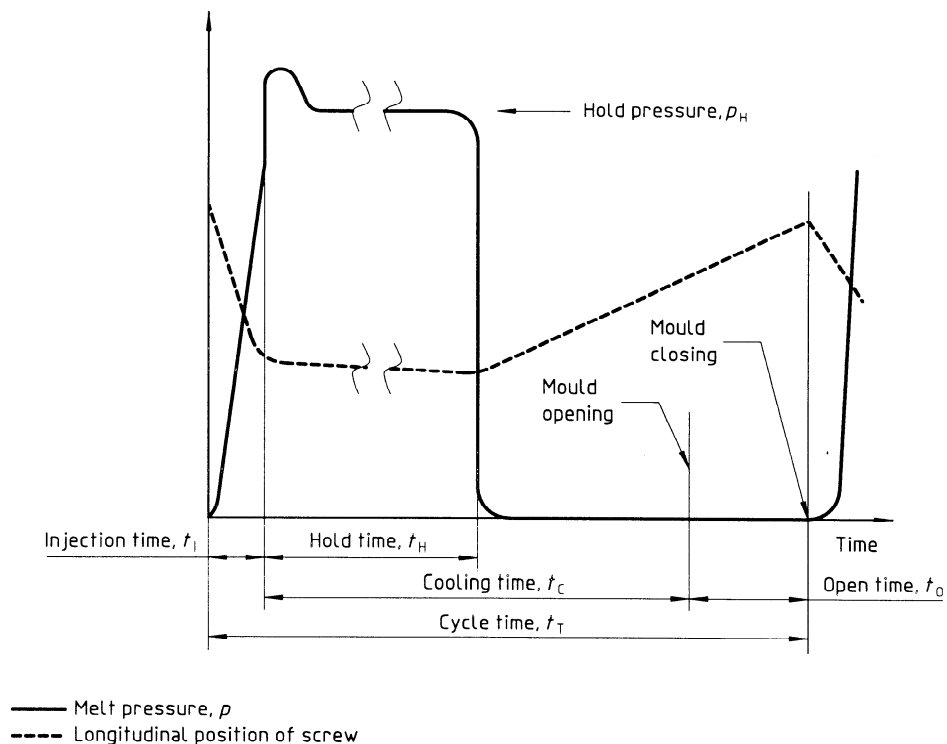

**Figure 1** — Schematic diagram of an injection-moulding cycle, showing the melt pressure (full line) and the longitudinal position of the screw (dashed line) as a function of time

**3.6 cycle time,  $t_T$ :** The time required to carry out a complete moulding cycle (see 3.5).

It is expressed in seconds (s).

The cycle time is the sum of the injection time  $t_i$ , the cooling time  $t_C$  and the mould-open time  $t_o$  (see 3.7, 3.8 and 3.10).

**3.7 injection time,  $t_i$ :** The time from the instant the screw starts to move forward until the switchover point between the injection period and the hold period.

It is expressed in seconds (s).

**3.8 cooling time,  $t_C$ :** The time from the end of the injection period until the mould starts to open.

It is expressed in seconds (s).

**3.9 hold time,  $t_H$ :** The time during which the pressure is maintained at the hold pressure (see 3.4).

It is expressed in seconds (s).

**3.10 mould-open time,  $t_o$ :** The time from the instant the mould starts to open until the mould is closed and exerts the full locking force.

It is expressed in seconds (s).

It includes the time required to remove the mouldings from the mould.

**3.11 cavity:** That part of the hollow space in a mould that produces one specimen.

**3.12 single-cavity mould:** A mould with one cavity only (see figure 4).

**3.13 multi-cavity mould:** A mould that has two or more identical cavities in a parallel-flow arrangement (see figures 2 and 3).

Identical flow-path geometries and symmetrical positioning of the cavities in the mould ensure that all test specimens from one shot are equivalent in their properties.

**3.14 family mould:** A mould that contains more than one cavity which have different geometries (see figure 5).

**3.15 ISO mould:** Any one of several standard moulds (designated type A, B, C, D1 and D2) intended for the reproducible preparation of test specimens with comparable properties. The moulds have a fixed plate with a central sprue, plus a multi-cavity cavity plate as described in 3.13.

Additional details are given in 4.1.1.4. An example of a complete mould is shown in annex C.

**3.16 critical cross-sectional area,  $A_C$ :** The cross-sectional area of the cavity in a single- or multi-cavity mould at the position where the critical portion of the test specimen, i.e. that part on which the measurement will be made, is moulded.

It is expressed in square millimetres ( $\text{mm}^2$ ).

For tensile-bar test specimens, for instance, the critical portion of the test specimen is the narrow section which is subjected to the greatest stress during testing.

**3.17 moulding volume,  $V_M$ :** The ratio of the mass of the moulding to the density of the solid plastic.

It is expressed in cubic millimetres ( $\text{mm}^3$ ).

**3.18 projected area,  $A_P$ :** The overall profile of the moulding projected on to the parting plane.

It is expressed in square millimetres ( $\text{mm}^2$ ).

**3.19 Locking force,  $F_M$ :** The force holding the plates of the mould closed.

It is expressed in kilonewtons (kN).

The minimum locking force necessary may be calculated from the inequality:

$$F_M \geq A_P \cdot p_{\max} \times 10^{-3} \quad \dots (2)$$

where

$F_M$  is the locking force, in kilonewtons;

$A_P$  is the projected area (see 3.18), in square millimetres;

$p_{\max}$  is the maximum value of the melt pressure (see 3.3), in megapascals.

**3.20 injection velocity,  $v_i$ :** The average velocity of the melt as it passes through the critical cross-sectional area  $A_C$  (see 3.16).

It is expressed in millimetres per second (mm/s).



It is applicable to single- and multi-cavity moulds only, and may be calculated from equation (3):

$$v_1 = \frac{V_M}{t_1 \cdot A_C \cdot n} \quad \dots (3)$$

where

- $v_1$  is the injection velocity, in millimetres per second;
- $n$  is the number of cavities;
- $A_C$  is the critical cross-sectional area (see 3.16), in square millimetres;
- $V_M$  is the moulding volume (see 3.17), in cubic millimetres;
- $t_1$  is the injection time (see 3.7), in seconds.

**3.21 shot capacity,  $V_S$ :** The product of the maximum metering stroke of the injection-moulding machine and the cross-sectional area of the screw.

It is expressed in cubic millimetres (mm<sup>3</sup>).

## 4 Apparatus

iTeh STANDARD PREVIEW  
(standards.iteh.ai)

### 4.1 Moulds

#### 4.1.1 ISO (multi-cavity) moulds

ISO 294-1:1996

**4.1.1.1** ISO moulds (see 3.15) are strongly recommended for producing test specimens for the acquisition of data which is intended to be comparable (see ISO 10350, ISO 11403-1, ISO 11403-2 and ISO 11403-3), as well as for use in the case of disputes involving International Standards.

**4.1.1.2** Multipurpose test specimens as specified in ISO 3167 shall be moulded in a two-cavity type A ISO mould using a Z- or T-runner (see annex A). The mould shall be as shown in figure 2 and meet the requirements specified in 4.1.1.4. Of the two types of runner, the Z-runner is preferred owing to the more symmetrical closure force obtained. The bar mouldings produced shall have the dimensions of the type A specimen specified in ISO 3167.

**4.1.1.3** Rectangular 80 mm × 10 mm × 4 mm bars shall be moulded in a four-cavity type B ISO mould with a double-T runner. The mould shall be as shown in figure 3 and meet the requirements specified in 4.1.1.4. The bars produced shall have the same cross-sectional dimensions along their central section as multipurpose test specimens (see ISO 3167) and a length of 80 mm ± 2 mm.

**4.1.1.4** The main constructional details of type A and B ISO moulds shall be as shown in figures 2 and 3 and shall meet the following requirements:

- a) The sprue diameter on the nozzle side shall be at least 4 mm.
- b) The width and height (or the diameter) of the runner system shall be at least 5 mm.
- c) The cavities shall be one-end gated as shown in figures 2 and 3.
- d) The height of the gate shall be at least two-thirds the height of the cavity, and the width of the gate shall be equal to that of the cavity at the point where the gate enters the cavity.
- e) The gate shall be as short as possible, in any case not exceeding 3 mm.

Dimensions in millimetres

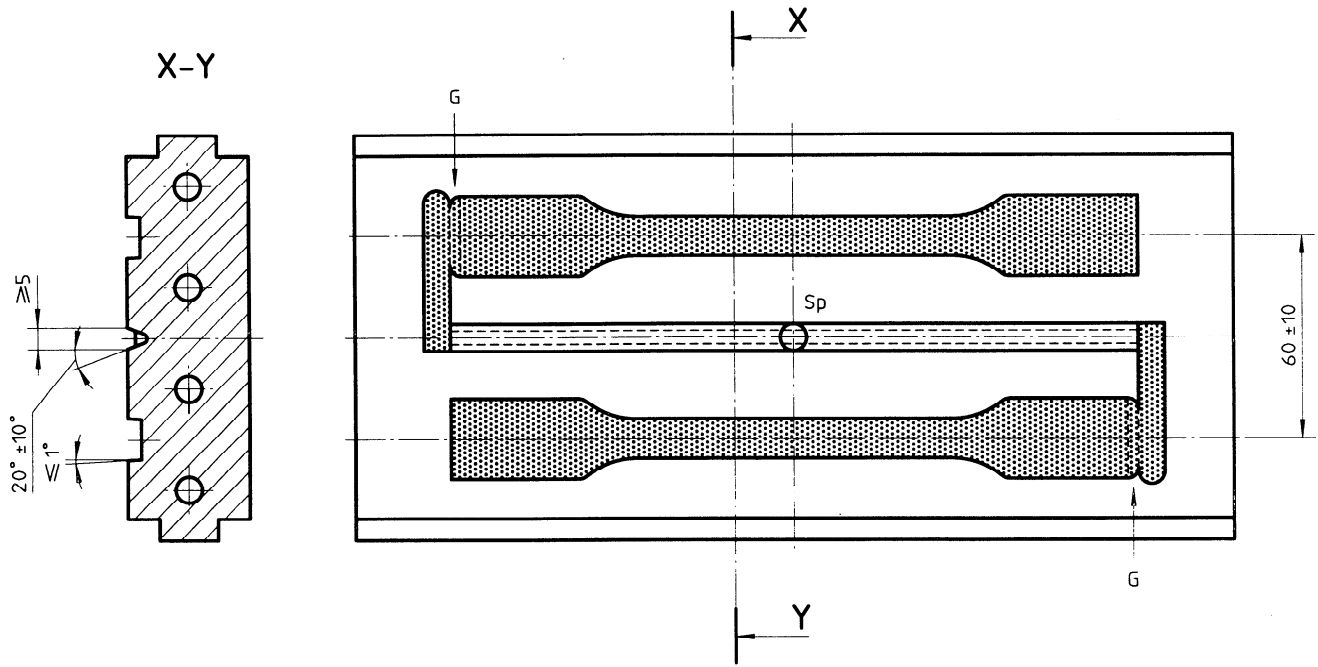

**Key**

Sp Sprue Moulding volume  $V_M \approx 30\,000\text{ mm}^3$   
 G Gates Projected area  $A_P \approx 6\,300\text{ mm}^2$

**Figure 2 — Cavity plate for a type A ISO mould**

ISO 294-1:1996  
<https://standards.iteh.ai/catalog/standards/sist/58974be9-8d4c-4dbe-b998-520c06ff0ce9/iso-294-1-1996>

Dimensions in millimetres

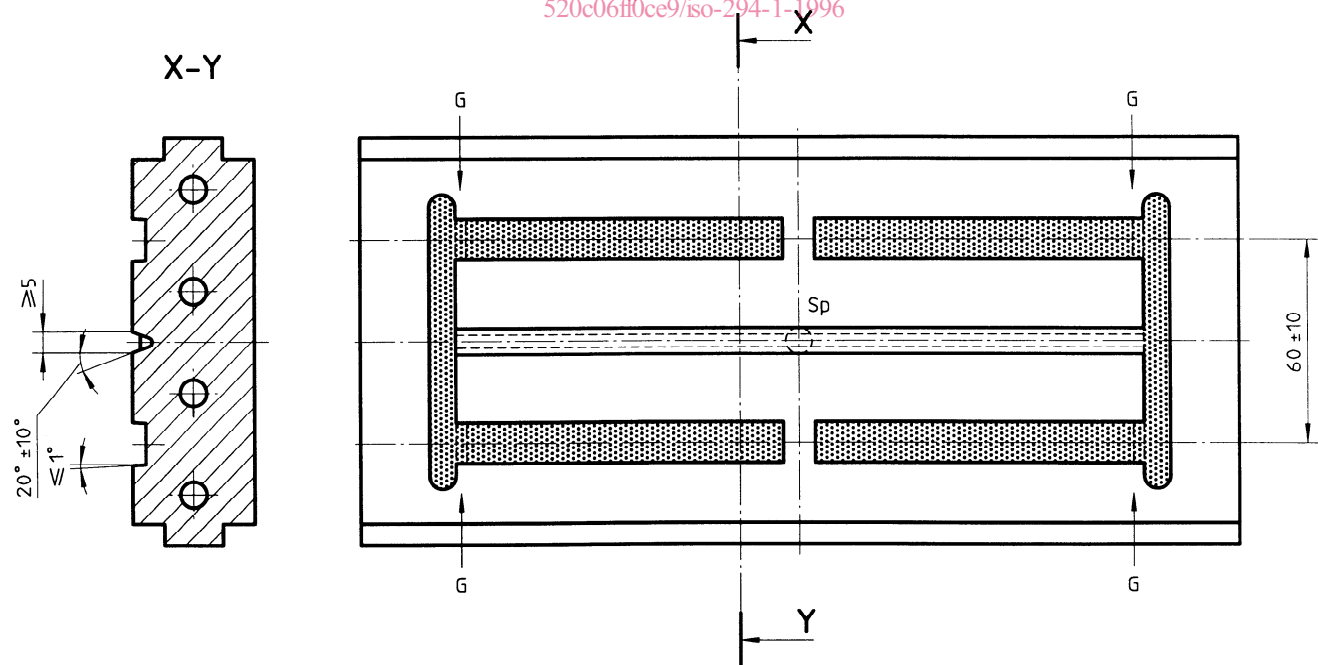

**Key**

Sp Sprue Moulding volume  $V_M \approx 30\,000\text{ mm}^3$   
 G Gates Projected area  $A_P \approx 6\,500\text{ mm}^2$

**Figure 3 — Cavity plate for a type B ISO mould**

- f) The draft angle of the runners shall be at least 10°, but not more than 30°. The cavity shall have a draft angle not greater than 1°, except in the area of tensile-specimen shoulders where the draft angle shall not be greater than 2°.
- g) The dimensions of the cavities shall be such that the dimensions of the test specimens produced conform to the requirements given in the relevant test standard. To allow for different degrees of moulding shrinkage, the dimensions of the cavities shall be chosen so that they are between the nominal value and the upper limit of the dimensions specified for the specimen concerned. In the case of type A and B ISO moulds, the main cavity dimensions, in millimetres, shall be as follows (see ISO 3167):
- depth: 4,0 to 4,2;
  - width of central section: 10,0 to 10,2;
  - length (type B mould): 80 to 82.
- h) Ejector pins, if used, shall be located outside the test area of the specimen, i.e. at the shoulders of dumbbell specimens produced from type A and type C ISO moulds (for type C, see ISO 294-2), outside the central 20 mm section of bar specimens from type B ISO moulds and outside the 60-mm-square section of plate specimens from type D ISO moulds (see ISO 294-3).
- i) The heating/cooling system for the mould plates shall be designed so that, under operating conditions, the difference in temperature between any point on the surface of a cavity and either plate is less than 5 °C.
- j) Interchangeable cavity plates and gate inserts are recommended to permit rapid changes in production from one type of test specimen to another. Such changes are facilitated by using shot capacities  $V_S$  which are as similar as possible. An example is shown in annex A.
- k) It is recommended that a pressure sensor be fitted in the central runner, to give proper control of the injection period (the sensor is mandatory for ISO 294-4). A sensor position suitable for the various types of ISO mould is given in subclause 4.1, item k) and in figure 2 of ISO 294-3:1996.
- l) To ensure that cavity plates are interchangeable between different ISO moulds, it is important to note the following constructional details in addition to those shown in figures 2 and 3 and those given in ISO 294-2 and ISO 294-3:
- 1) It is recommended that a cavity length of 170 mm be used for multipurpose test specimens moulded in the type A ISO mould. This gives a maximum length of 180 mm for the space between the cavity plates.
  - 2) The width of the mould plates may be affected by the minimum distance required between the connection points for the heating/cooling channels. In addition, space may need to be provided in type B ISO moulds for the fitting of a special insert enabling notched bars for use in ISO 179 to be moulded.
  - 3) Lines along which the test specimens can be cut from the runners may be defined e.g. 170 mm apart for type A, B and C ISO moulds (for type C, see ISO 294-2). A second pair of lines 80 mm apart may be defined for cutting bars from multipurpose test specimens from a type A mould and may be used as well for cutting off small-plate mouldings (see ISO 294-3).
- m) To make it easier to check that all the specimens from a mould are identical, it is recommended that the individual cavities be marked, but outside the test area of the specimen [see item h) above]. This can be done very simply by engraving suitable symbols on the heads of the ejector pins, thus avoiding any damage to the surface of the cavity plate.
- n) Surface imperfections can influence the results, especially those of mechanical tests. Where appropriate, the surfaces of the mould cavities shall be highly polished therefore, the direction of polishing corresponding to the direction in which the test specimen will be placed under load when it is tested.

**4.1.1.5** For more information on those mould components described in other International Standards, the reader is referred to annex B.