



SLOVENSKI STANDARD
SIST ISO 294-3:1997

01-april-1997

Polimerni materiali - Preskušanci plastomerov, oblikovani z injekcijskim vbrizgavanjem - 3. del: Ploščice

Plastics -- Injection moulding of test specimens of thermoplastic materials -- Part 3: Small plates

iTeh STANDARD PREVIEW

Plastiques -- Moulage par injection des éprouvettes de matériaux thermoplastiques --
Partie 3: Plaques de petites dimensions

[SIST ISO 294-3:1997](https://standards.iteh.ai/catalog/standards/sist/7a0ee082-9424-48f3-a250-61e1d4f53631/sist-iso-294-3-1997)

Ta slovenski standard je istoveten z: ISO 294-3:1996

ICS:

83.080.20 Plastomeri Thermoplastic materials

SIST ISO 294-3:1997 **en**

iTeh STANDARD PREVIEW
(standards.iteh.ai)

[SIST ISO 294-3:1997](#)

<https://standards.iteh.ai/catalog/standards/sist/7a0ee082-9424-48f3-a250-b1e1d4453631/sist-iso-294-3-1997>

INTERNATIONAL
STANDARD

ISO
294-3

First edition
1996-12-15

**Plastics — Injection moulding of test
specimens of thermoplastic materials —**

Part 3:
Small plates
(standards.iteh.ai)

<https://standards.iteh.ai/standards/iso-294-3-1997>
*Plastiques — Moulage par injection des éprouvettes de matériaux
thermoplastiques — 294-3-1997*

Partie 3: Plaques de petites dimensions



Reference number
ISO 294-3:1996(E)

ISO 294-3:1996(E)**Foreword**

ISO (the International Organization for Standardization) is a worldwide federation of national standards bodies (ISO member bodies). The work of preparing International Standards is normally carried out through ISO technical committees. Each member body interested in a subject for which a technical committee has been established has the right to be represented on that committee. International organizations, governmental and non-governmental, in liaison with ISO, also take part in the work. ISO collaborates closely with the International Electrotechnical Commission (IEC) on all matters of electrotechnical standardization.

Draft International Standards adopted by the technical committees are circulated to the member bodies for voting. Publication as an International Standard requires approval by at least 75 % of the member bodies casting a vote.

International Standard ISO 294-3 was prepared by Technical Committee ISO/TC 61, *Plastics*, Subcommittee SC 9, *Thermoplastic materials*.

Together with the other parts, this part of ISO 294 cancels and replaces the second edition of ISO 294 (ISO 294:1995) which has been revised to improve the definition of the injection-moulding parameters and has been restructured to specify four types of ISO mould for the production of the basic specimen types required for the acquisition of comparable test data.

Care has been taken to ensure that the ISO moulds described can all be fitted in existing injection-moulding equipment and have interchangeable cavity plates.

ISO 294 consists of the following parts, under the general title *Plastics — Injection moulding of test specimens of thermoplastic materials*:

- *Part 1: General principles, and moulding of multipurpose and bar test specimens*
- *Part 2: Small tensile bars*
- *Part 3: Small plates*
- *Part 4: Determination of moulding shrinkage*

Annexes A to C of this part of ISO 294 are for information only.

© ISO 1996

All rights reserved. Unless otherwise specified, no part of this publication may be reproduced or utilized in any form or by any means, electronic or mechanical, including photocopying and microfilm, without permission in writing from the publisher.

International Organization for Standardization
Case Postale 56 • CH-1211 Genève 20 • Switzerland

Printed in Switzerland

Plastics — Injection moulding of test specimens of thermoplastic materials —

Part 3: Small plates

1 Scope

This part of ISO 294 specifies two two-cavity moulds, the type D1 and D2 ISO moulds, for the injection moulding of small plates measuring 60 mm × 60 mm with a preferred thickness of 1 mm (type D1) or 2 mm (type D2) which can be used for a variety of tests (see annex A). The moulds may additionally be fitted with inserts for studying the effects of weld lines on the mechanical properties (see annex B).

2 Normative references

[SIST ISO 294-3:1997](https://standards.iteh.ai/catalog/standards/sist/7a0ee082-9424-48f3-a250-b1e1d4453631/sist-iso-294-3-1997)

<https://standards.iteh.ai/catalog/standards/sist/7a0ee082-9424-48f3-a250-b1e1d4453631/sist-iso-294-3-1997>

The following standards contain provisions which, through reference in this text, constitute provisions of this part of ISO 294. At the time of publication, the editions indicated were valid. All standards are subject to revision, and parties to agreements based on this part of ISO 294 are encouraged to investigate the possibility of applying the most recent editions of the standards indicated below. Members of IEC and ISO maintain registers of currently valid International Standards.

ISO 294-1:1996, *Plastics — Injection moulding of test specimens of thermoplastic materials — Part 1: General principles, and moulding of multipurpose and bar test specimens.*

ISO 294-4:—¹⁾, *Plastics — Injection moulding of test specimens of thermoplastic materials — Part 4: Determination of moulding shrinkage.*

ISO 6603-1:1985, *Plastics — Determination of multiaxial impact behaviour of rigid plastics — Part 1: Falling dart method.*

ISO 6603-2:1989, *Plastics — Determination of multiaxial impact behaviour of rigid plastics — Part 2: Instrumented puncture test.*

3 Definitions

See ISO 294-1:1996, clause 3.

1) To be published. (Revision in part of ISO 294:1995)

4 Apparatus

4.1 Type D1 and D2 ISO moulds

Type D1 and D2 ISO moulds are two-cavity moulds (see figure 1) intended for the preparation of plates measuring 60 mm × 60 mm. The plates produced using these moulds shall have the dimensions given in figure 2.

The main constructional details of type D1 and D2 ISO moulds shall be as shown in figures 1 and 2 and shall meet the following requirements:

- See ISO 294-1:1996, subclause 4.1.1.4, item a).
- Not applicable.
- See ISO 294-1:1996, subclause 4.1.1.4, item c).
- d) and e) Not applicable.
- See ISO 294-1:1996, subclause 4.1.1.4, item f).
- See ISO 294-1:1996, subclause 4.1.1.4, item g), but with reference to ISO 6603.

The main dimensions, in millimetres, of the cavities shall be as follows (see also figure 2):

- length: 60 to 62;
- width: 60 to 62;
- depth: type D2 mould 2,0 to 2,1
type D1 mould 1,0 to 1,1

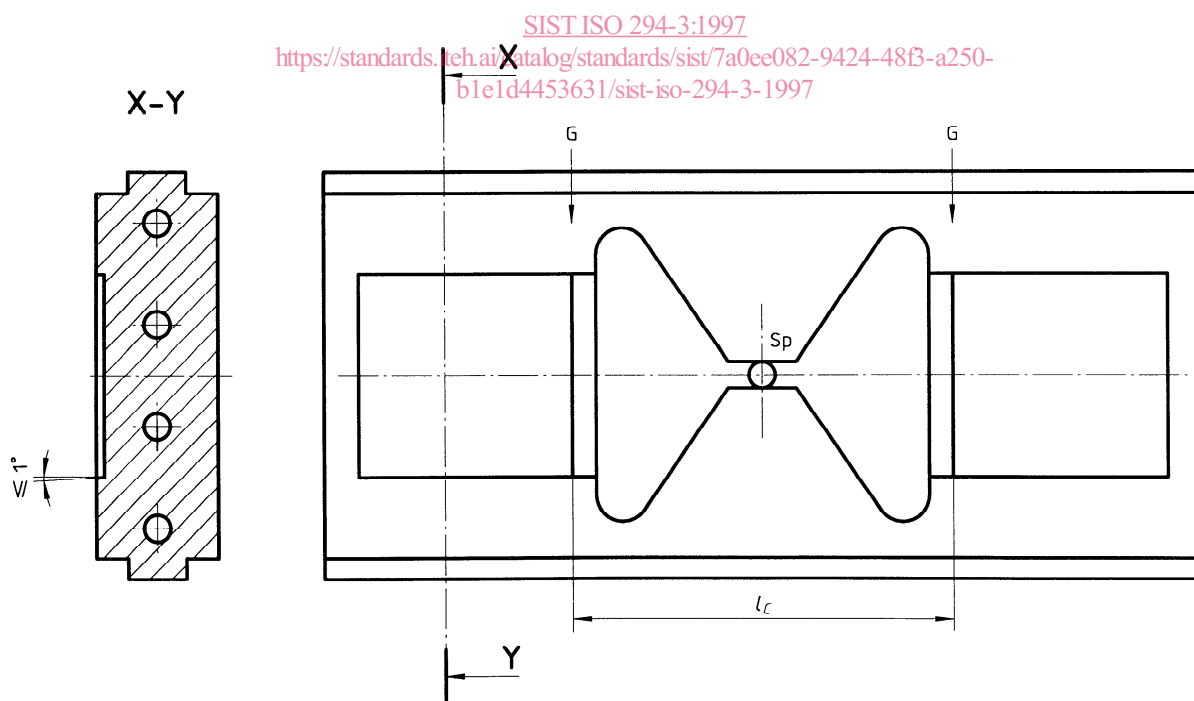

Key

- | | | |
|-------|--|---|
| Sp | Sprue | Moulding volume $V_M \approx 30\,000\text{ mm}^3$ (at 2 mm thickness) |
| G | Gate | Projected area $A_P \approx 11\,000\text{ mm}^2$ |
| l_C | is the distance between the lines along which the test specimens are cut from the runners (see notes 3 and 4 in subclause 4.1) | |

Figure 1 — Cavity plate for type D1 and D2 ISO moulds

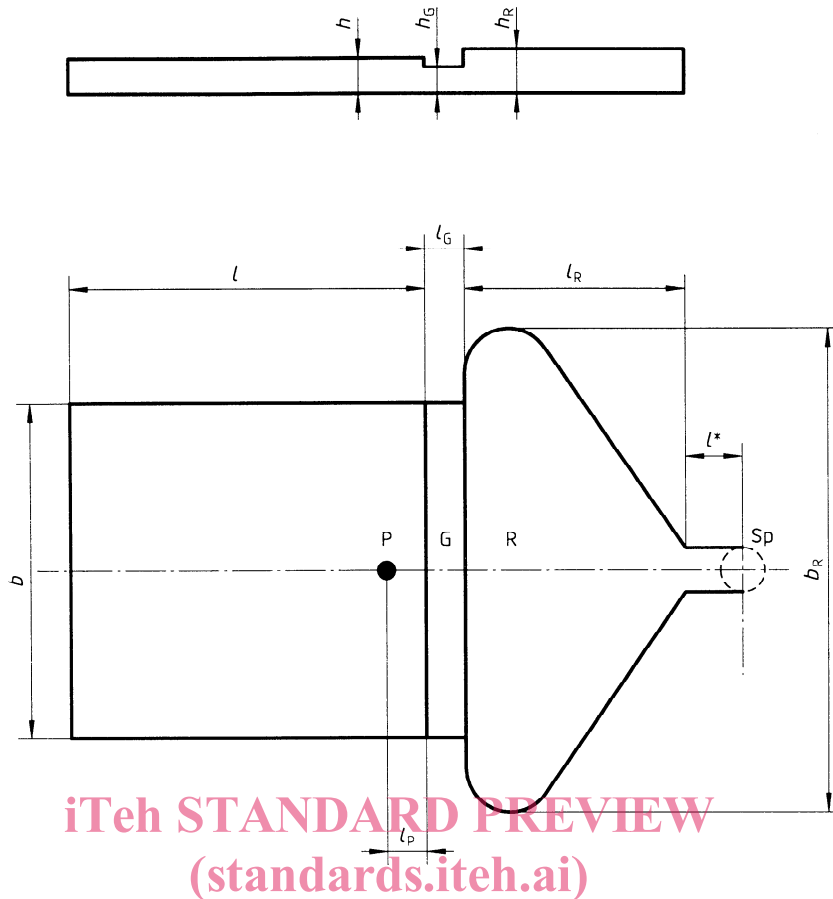
**Key**

Sp	Sprue	SIST ISO 294-3:1997
G	Gate	http://standards.iteh.ai/catalog/standards/sist/7a0ee082-9424-48f3-a250-b1e1d4453631/sist-iso-294-3-1997
R	Runner	
P	Pressure sensor	

		Dimensions in mm
l	Length of plate	$60 \pm 2^1)$
b	Width of plate	$60 \pm 2^1)$
h	Thickness of plate: type D1 mould type D2 mould	$1,0 \pm 0,1$ $2,0 \pm 0,1^1)$
l_G	Length of gate	$4,0 \pm 0,1^2)$
h_G	Height of gate	$(0,75 \pm 0,05) \times h^3)$
l_R	Length of runner	25 to 30 ⁴⁾
b_R	Width of runner at gate	$\geq (b + 6)$
h_R	Depth of runner at gate	$h + (1,5 \pm 0,5)$
l^*	Unspecified distance	—
l_P	Distance of pressure sensor from gate	$5 \pm 2^5)$

- 1) These dimensions are for the preferred test specimen used in ISO 6603.
- 2) See notes 2 and 3 in subclause 4.1.
- 3) See notes 1 and 2 in subclause 4.1.
- 4) See note 4 in subclause 4.1.
- 5) The position of the pressure sensor shall be further limited by the following conditions:

$$l_P + r_P \leq 10$$

$$l_P - r_P \geq 0$$

where r_P is the radius of the sensor.

Figure 2 — Details of type D1 and D2 ISO moulds

- h) to j) See ISO 294-1:1996, subclause 4.1.1.4, items h) to j).
- k) Figure 2 shows the position of a pressure sensor P within the cavity, which is mandatory for the measurement of moulding shrinkage only (see ISO 294-4). It may be useful, however, in controlling the injection period with any ISO mould [see ISO 294-1:1996, subclause 4.1.1.4, item k)]. The pressure sensor shall be flush with the cavity surface in order to avoid interference of the melt flow.
- l) to n) See ISO 294-1:1996, subclause 4.1.1.4, items l) to n).

NOTES

- 1 Gates which are severely limited in height have a great influence on the orientation of the material within the cavity, even at large distances from the gate. The change in height at the gate has therefore been fixed at a value which facilitates subsequent measurement of the moulding shrinkage (see ISO 294-4).
- 2 The height and length of the gate strongly influence the process of solidification of the melt as it flows into the cavity, and hence the moulding shrinkage (see ISO 294-4). The dimensions of the gate are therefore defined with tight tolerances.
- 3 The value specified for the gate length l_G allows the two test specimens to be cut from the runners with a fixed distance l_C between the cuts (see figure 1), even when the moulding shrinkage varies from one material to another.
- 4 The distance l_C between the lines along which the test specimens are cut from the runners (see figure 1) is given by $l_C = 2(l_G + l_R + l^*)$ (see figure 2). Taking this distance as 80 mm gives the advantage that the same cutting machine can be used to cut 80 mm × 10 mm × 4 mm bars from the central sections of multipurpose test specimens [see ISO 294-1:1996, subclause 4.1.1.4, item l)].

4.2 Injection-moulding machine

See ISO 294-1:1996, subclause 4.2, with the following exception:

In subclause 4.2.4, the recommended minimum locking force F_M for type D1 and D2 ISO moulds is given by $F_M \geq 11\,000 \times p_{\max} \times 10^{-3}$, i.e. 880 kN for a maximum melt pressure of 80 MPa.

5 Procedure

5.1 Conditioning of material

See ISO 294-1:1996, subclause 5.1.

5.2 Injection moulding

See ISO 294-1:1996, subclause 5.2, but with the following new text for subclause 5.2.2.

For type D1 and D2 ISO moulds, it is recommended that the injection velocity v_i be chosen such that the injection time t_i is comparable to that used for the type A ISO mould.

6 Report on test-specimen preparation

The report shall include the following information:

- a) a reference to this part of ISO 294;
- b) to h): see ISO 294-1:1996, clause 6, items b) to h).

Annex A (informative)

Recommended applications for small-plate test specimens or parts thereof

The type D2 ISO mould is recommended for the preparation of test specimens for use in determining multi-axial impact properties as described in ISO 6603 (see note 1), moulding shrinkage as described in ISO 294-4 and optical properties (see note 2), in preparing specimens of coloured plastics (see note 3), in studying the anisotropy of mechanical properties (see note 4) and, with the mould fitted with gate inserts, in studying the effects of weld lines (see annex B).

The type D1 ISO mould is especially suitable for producing test specimens for use in determining electrical properties (see note 5), water absorption (see note 6) and dynamic mechanical properties (see note 7).

NOTES

- 1 It is proposed that multi-axial impact strength be included with the mechanical properties in ISO 10350^[8] and ISO 11403-1^[9]. The recommended specimen thickness is 2 mm.
- 2 Plate specimens produced from natural or essentially colourless materials are suitable for determining the refractive index (see reference [2] in annex C) and luminous transmittance (see references [10] and [11] in annex C).
- 3 Plate specimens produced from coloured or natural materials are suitable for use in determining optical and mechanical properties in order to study the influence of weathering in accordance with e.g. ISO 4892-2^[5].
- 4 Type 4 tensile test specimens as specified in ISO 8256^[7], taken at different positions and oriented in different directions from plate mouldings by machining in accordance with ISO 2818^[4], are suitable for use in studying the anisotropy of mechanical properties by tensile and tensile-impact testing as described in ISO 527-1^[3] and ISO 8256^[7], respectively.
- 5 ISO 10350^[8] recommends the measurement of the following electrical properties: relative permittivity and dissipation factor, volume resistivity, surface resistivity and electric strength using plate specimens 1 mm thick and ≥ 80 mm square (which will be changed to ≥ 60 mm square at the next revision of ISO 10350).
- 6 ISO 10350^[8] recommends the measurement of water absorption as described in ISO 62^[11] using a test specimen ≤ 1 mm thick in order to be able to determine the saturation value within a reasonable test time.
- 7 ISO 6721-2^[6] describes the determination of the complex shear modulus using a torsion pendulum and specimens preferably with a thickness of 1 mm. These can be taken from mouldings produced by a type D1 ISO mould.