**Information technology — Remote
Operations: OSI realizations — Remote
Operations Service Element (ROSE)
protocol specification**

iTeh STANDARD PREVIEW

**AMENDMENT 1: Mapping to A-UNIT-DATA
and built-in operations**

[ISO/IEC 13712-3:1995/Amd 1:1996](https://standards.iso.org/iso/iec/13712-3/1995/amd-1/1996)

[https://standards.iteh.ai/catalog/standards/sist/071912ec-471b-4790-b82b-](https://standards.iteh.ai/catalog/standards/sist/071912ec-471b-4790-b82b-2b5e728750cc/iso-iec-13712-3-1995-amd-1-1996)

[2b5e728750cc/iso-iec-13712-3-1995-amd-1-1996](https://standards.iteh.ai/catalog/standards/sist/071912ec-471b-4790-b82b-2b5e728750cc/iso-iec-13712-3-1995-amd-1-1996)

*Technologies de l'information — Opérations à distance: Réalisations
OSI — Spécification du protocole pour l'élément de service des opérations
à distance (ROSE)*

*AMENDEMENT 1: Correspondance avec A-Unit-Data et opérations
intégrées*



Contents

Page

1) Clause 1	1
2) Subclause 2.1.....	1
3) Subclause 6.2.....	1
4) Subclause 6.3.....	2
5) Clause 8.....	2
8 Built-in operations.....	2
6) Clause 9.....	3
7) Subclause 9.3.2.....	3
8) Clause 10.....	3
9) Clause 10.....	4
10) Clause 11.....	4
11) Subclause A.1.....	4
12) Subclause A.4.....	5
13) Subclause A.5.....	5
14) Annex C.....	6
15) Annex D.....	6

iTeh STANDARD PREVIEW
(standards.iteh.ai)

ISO/IEC 13712-3:1995/Amd.1:1996
<https://standards.iteh.ai/catalog/standards/sist/071912ec-471b-4790-b82b-2b5e83dba5c/iso-iec-13712-3-1995-amd-1-1996>

© ISO/IEC 1996

All rights reserved. Unless otherwise specified, no part of this publication may be reproduced or utilized in any form or by any means, electronic or mechanical, including photocopying and microfilm, without permission in writing from the publisher.

ISO/IEC Copyright Office • Case postale 56 • CH-1211 Genève 20 • Switzerland

Printed in Switzerland

Foreword

ISO (the International Organization for Standardization) and IEC (the International Electrotechnical Commission) form the specialized system for worldwide standardization. National bodies that are members of ISO or IEC participate in the development of International Standards through technical committees established by the respective organization to deal with particular fields of technical activity. ISO and IEC technical committees collaborate in fields of mutual interest. Other international organizations, governmental and non-governmental, in liaison with ISO and IEC, also take part in the work.

In the field of information technology, ISO and IEC have established a joint technical committee, ISO/IEC JTC 1. Draft International Standards adopted by the joint technical committee are circulated to national bodies for voting. Publication as an International Standard requires approval by at least 75 % of the national bodies casting a vote.

iTeh STANDARD PREVIEW
(standards.iteh.ai)

Amendment 1 to International Standard ISO/IEC 13712-3:1995 was prepared by Joint Technical Committee ISO/IEC JTC 1, *Information technology*, Subcommittee SC 21, *Open systems interconnection, data management and open distributed processing*, in collaboration with ITU-T. The identical text is published as ITU-T Rec. X.882/Amd.1.

<https://standards.iteh.ai/catalog/standards/sist/071912ec-471b-4790-b82b-2f35e83dba5c/iso-iec-13712-3-1995-amd-1-1996>

Introduction

This amendment to Rec. X.882 | ISO/IEC 13712-3 provides the protocol procedures for the mapping of ROSE APDUs onto the A-UNIT-DATA service, and the inclusion of three built-in operations – Probe, Acknowledge and Cancel – which are of general utility to designers of ROSE-based applications.

iTeh STANDARD PREVIEW (standards.iteh.ai)

[ISO/IEC 13712-3:1995/Amd 1:1996](https://standards.iteh.ai/catalog/standards/sist/071912ec-471b-4790-b82b-2f35e83dba5c/iso-iec-13712-3-1995-amd-1-1996)

<https://standards.iteh.ai/catalog/standards/sist/071912ec-471b-4790-b82b-2f35e83dba5c/iso-iec-13712-3-1995-amd-1-1996>

INTERNATIONAL STANDARD

ITU-T RECOMMENDATION

INFORMATION TECHNOLOGY – REMOTE OPERATIONS: OSI REALIZATIONS –
REMOTE OPERATIONS SERVICE ELEMENT (ROSE) PROTOCOL SPECIFICATIONAMENDMENT 1
Mapping to A-UNIT-DATA and built-in operations

1) Clause 1

Rewrite the third sentence of the first paragraph as follows (with the changes underlined):

The ROSE services, defined in ITU-T Rec. X.881 | ISO/IEC 13712-2, are provided in conjunction with the Association Control Service Element (ACSE) services (ITU-T Rec. X.217 | ISO/IEC 8649) and the ACSE protocol (ITU-T Rec. X.227 | ISO/IEC 8650-1 and ITU-T Rec. X.237 | ISO/IEC 10035-1), optionally the Reliable Transfer Service Element (RTSE) services (ITU-T Rec. X.218 | ISO/IEC 9066-1) and the RTSE protocol (ITU-T Rec. X.228 | ISO/IEC 9066-2), and the Presentation service (ITU-T Rec. X.216 | ISO/IEC 8822).

2) Subclause 2.1

Add the following references:

- ITU-T Recommendation X.237 (1995) | ISO/IEC 10035-1:1995, *Information technology – Open Systems Interconnection – Connectionless protocol for the Association Control Service Element: Protocol specification.*
- ITU-T Recommendation X.880 (1994)/Amd.1 (1995) | ISO/IEC 13712-1:1995/Amd.1:1996, *Information technology – Remote Operations: Concepts, model and notation – Amendment 1: Built-in operations.*
- ITU-T Recommendation X.881 (1994)/Amd.1 (1995) | ISO/IEC 13712-2:1995/Amd.1:1996, *Information technology – Remote Operations: OSI realizations – Remote Operations Service Element (ROSE) service definition – Amendment 1: Mapping to A-UNIT-DATA and built-in operations.*

3) Subclause 6.2

Rewrite the last paragraph as follows (with additions underlined and deletions struckthrough):

Two specific association realizations are included, one based upon ACSE and one on RTSE. ~~Two~~Three specific transfer realizations are included, based respectively on the use of P-DATA, A-UNIT-DATA and RT-DATA to transfer the APDUs.

4) Subclause 6.3

Replace the existing Figure 1 with the following figure:

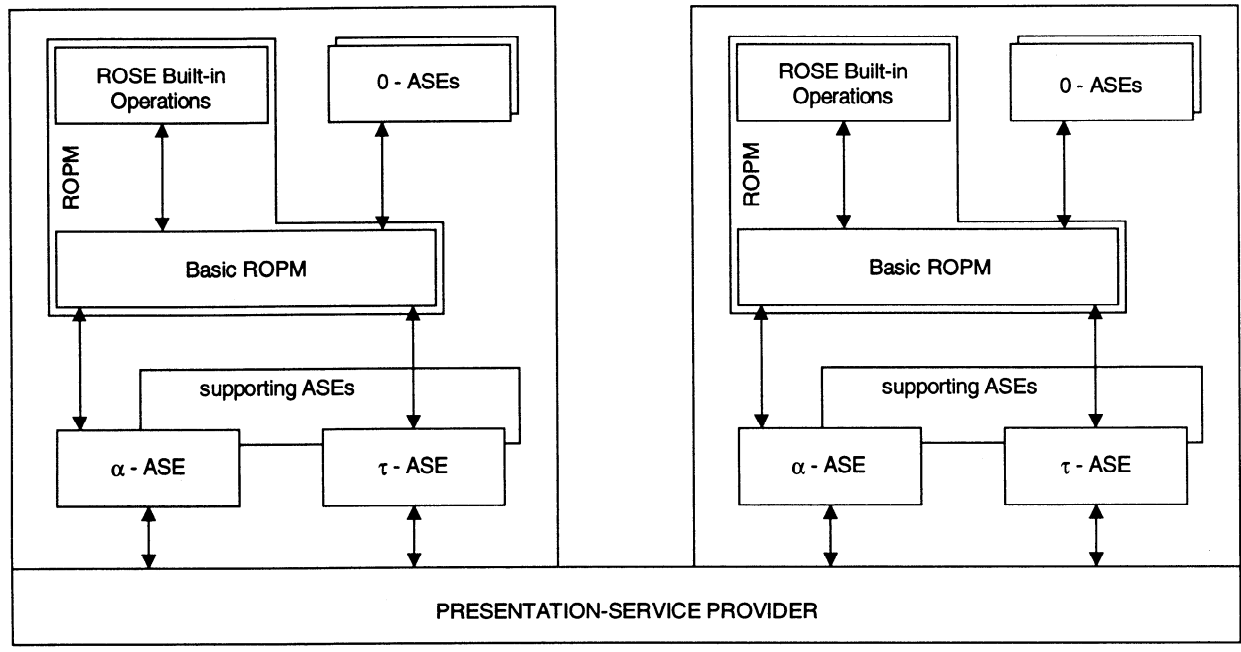

TIS07000-96/d01

- α - ASE ASE providing association establishment and release
- τ - ASE ASE providing information transfer
- ROPM Remote Operations protocol machine
- O - ASEs Operation-specific ASEs

PREVIEW
(standards.iteh.ai)
 ISO/IEC 13712-3:1995/Amd 1:1996
<https://standards.iteh.ai/catalog/standards/sis/071101ec-471b-4790-b82b-2f35e83dba5c/iso-iec-13712-3-1995-amd-1-1996>
Figure 1 – Protocol model

5) Clause 8

Change clause 8 to 9, and similarly for all subclauses contained therein.

Add the following new clause 8:

8 Built-in operations

8.1 Probe and acknowledge

If the probe or acknowledge operation is included in the application context, then a ROPM, having sent a ReturnResult or ReturnError APDU for a non-idempotent operation retains that APDU until it has been acknowledged. While retained, that APDU is re-sent if a probe takes place during that period. As a local matter, the APDU may also be re-sent periodically.

A retained ReturnResult or ReturnError APDU is considered acknowledged, and can be deleted, if:

- a) the operation to which the retained APDU was a reply is synchronous, and a synchronous operation is subsequently invoked by the same invoker; or
- b) the acknowledge operation is invoked by the same invoker, citing the operation invocation to which the operation invocation to which the retained APDU was the return; or
- c) having re-sent the APDU, a Reject APDU is received, citing the operation invocation to which the retained APDU was the return, and indicating, if the retained APDU was a ReturnResult, returnResult : resultResponseUnexpected or, if the retained APDU was a ReturnError, returnError : errorResponseUnexpected.

If probe or acknowledge is included in the application context, then an ROPM having received a ReturnResult or ReturnError APDU for a non-idempotent operation shall acknowledge such receipt either:

- a) if the operation to which the received APDU was a reply is synchronous, by subsequently invoking a synchronous operation; or
- b) by invoking the acknowledge operation, citing the operation invocation to which the received APDU was a return. The acknowledge operation, which is idempotent, can be invoked repeatedly until it produces a result.

6) Clause 9

Renumber clause 9 as 10, and similarly for all subclauses contained therein.

Renumber subclause 9.1 as 10.1 and modify the first paragraph as shown below (with additions underlined and deletions struckthrough):

A transfer realization may require the inclusion in the application context of an ASE which provides services for the transfer of information. Alternatively, the realization may involve direct use of the presentation service. The realization may require a number of supporting ASEs to be present. ~~Two~~Three transfer realizations are specified in this clause. The P-DATA realization is specified in ~~9.2~~10.2, and uses the connection-oriented services of the Presentation service directly. The A-UNIT-DATA realization uses the connectionless-mode OSI upper layer services and is specified in 10.3. The RT-TRANSFER realization is specified in ~~9.3~~10.4.

Renumber 9.2 as 10.2.

Renumber 9.3 as 10.4.

iTeh STANDARD PREVIEW
(standards.iteh.ai)

7) Subclause 9.3.2

Renumber the existing Table 18 as Table 19 [SO/IEC 13712-3:1995/Amd 1:1996](https://standards.iteh.ai/catalog/standards/sist/071912ec-471b-4790-b82b-2f35e83dba5c/iso-iec-13712-3-1995-amd-1-1996)
<https://standards.iteh.ai/catalog/standards/sist/071912ec-471b-4790-b82b-2f35e83dba5c/iso-iec-13712-3-1995-amd-1-1996>

8) Clause 10

Add a new subclause 10.3 as shown below:

10.3 A-UNIT-DATA

10.3.1 This subclause specifies a transfer realization employing the A-UNIT-DATA service of ACSE.

10.3.2 The *TRANSFER* service assumed by ROSE is provided as shown in Table 18.

Table 18 – Actual transfer primitives for the A-UNIT-DATA realization

Pseudo-primitive	Actual primitive(s)
<i>TRANSFER</i>	A-UNIT-DATA
user-data	User information

10.3.3 This realization imposes a maximum size of the APDU which can be transferred.

NOTE – The value of this maximum size is for further study.

10.3.4 This realization permits several *TRANSFER* requests arising close to one another in time to be combined into a single A-UNIT-DATA request. Each *TRANSFER* request conveys a single ROSE APDU, a presentation data value (PDV). The A-UNIT-DATA carries all the concatenated PDVs.

10.3.5 The realization specified in this subclause can be included as the **&transferRealization** field of an APPLICATION-CONTEXT by referencing the definition **aUnitData**:

```

aUnitData REALIZATION ::=
{RealizationParameter (WITH COMPONENT {realization-type(transfer-service)})
IDENTIFIED BY (joint-iso-ccitt association-control(2) abstract-syntax(1) apdus(1) version(1))
}
    
```

9) Clause 10

Renumber clause 10 as clause 11 and similarly for all its subclauses.

10) Clause 11

Renumber clause 11 as clause 12.

Renumber 11.1 as subclause 12.1, and modify as follows (with additions underlined and deletions struckthrough):

An implementor shall state the following:

- a) the application context for which conformance is claimed, including whether the system supports the mapping of ROSE onto RTSE, onto the Presentation service, or A-UNIT-DATA or ~~both combinations of these mappings.~~

Renumber 11.2 and 11.3 as 12.2 and 12.3 respectively.

11) Subclause A.1 **iTeh STANDARD PREVIEW**

Replace Figure A.1 with the following figure: <https://standards.iteh.ai/catalog/standards/sist/071912ec-471b-4790-8e22-2f35e83dba51/iso-iec-13712-3-1995-amd-1-1996> (standards.iteh.ai)

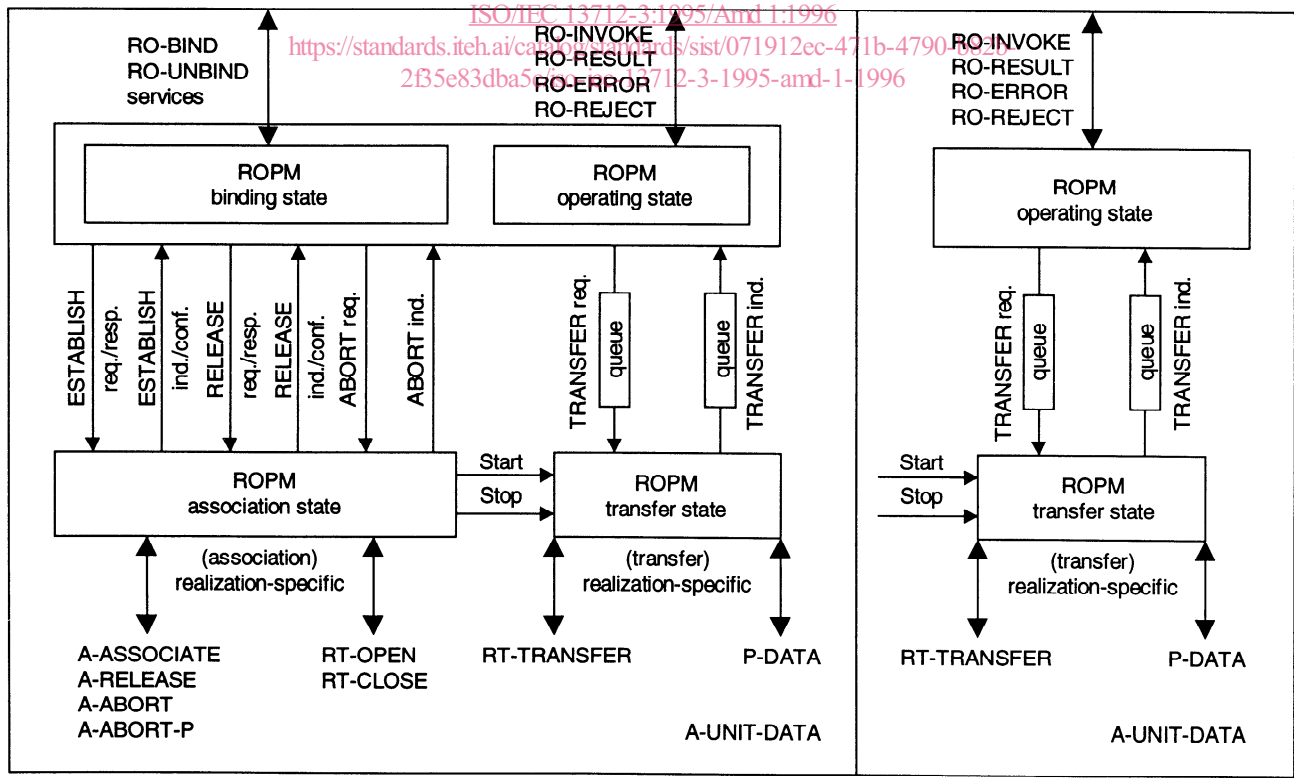

a) Connection package involved

b) No Connection package involved

Figure A.1 – Components of the ROPM state

12) Subclause A.4

Modify the itemized list of tables at the end of A.4 as follows (with additions underlined, and deletions struckthrough):

A.5 Transfer state table – A-UNIT-DATA realization

~~A.5~~A.6 Transfer state table – RT-TRANSFER realization

13) Subclause A.5

Add the following new tables numbered A.5 and renumber existing Table A.5 as A.6:

Table A.5(IN) – Transfer state – A-UNIT-DATA realization

Abbreviated name	Source	Name and description
TRANSreq	primary	<i>TRANSFER</i> request
PDV	ACSE	PDV carried within an A-UNIT-DATA indication.
start	association	start the transfer state machine
stop	association	stop the transfer state machine

Table A.5(ST) – Transfer state – A-UNIT-DATA realization

Abbreviated name	Name and description
TAU01	inactive https://standards.iteh.ai/catalog/standards/sist/071912ec-471b-4790-b82b-2f35856a3c/iso-iec-13712-3-1995-amd-1-1996
TAU02	active

Table A.5(OUT) – Transfer state – A-UNIT-DATA realization

Abbreviated name	Target	Name and description
TRANSind	primary	<i>TRANSFER</i> indication
PDV	ACSE	PDV carried on an A-UNIT-DATA request

Table A.5(TABLE) – Transfer state – A-UNIT-DATA realization

	TAU01	TAU02
TRANSreq		PDV TAU02
PDV		TRANSind TAU02
start	TAU02	
stop		TAU01