**Photography — Projection in indoor
rooms —**

Part 3:

Classification of transmitting projection screens
and measurement of their transmitted
luminance levels

iTeh STANDARD PREVIEW
(standards.iteh.ai)

Photographie — Projection en salles —

*Partie 3: Classification des écrans de projection par transmission et
mesurage de leurs niveaux de luminance transmise*

<https://standards.iteh.ai/catalog/standards/sist/218fa502-290f-4e7d-b0de-2a1da94ea2ac/iso-11315-3-1999>



Foreword

ISO (the International Organization for Standardization) is a worldwide federation of national standards bodies (ISO member bodies). The work of preparing International Standards is normally carried out through ISO technical committees. Each member body interested in a subject for which a technical committee has been established has the right to be represented on that committee. International organizations, governmental and non-governmental, in liaison with ISO, also take part in the work. ISO collaborates closely with the International Electrotechnical Commission (IEC) on all matters of electrotechnical standardization.

Draft International Standards adopted by the technical committees are circulated to the member bodies for voting. Publication as an International Standard requires approval by at least 75 % of the member bodies casting a vote.

International Standard ISO 11315-3 was prepared by Technical Committee ISO/TC 42, *Photography*.

ISO 11315 consists of the following parts, under the general title *Photography — Projection in indoor rooms*:

- *Part 1: Screen illumination test for still projectors*
- *Part 2: Screen luminance test for still and video projection*
- *Part 3: Classification of transmitting projection screens and measurement of their transmitted luminance levels*
- *Part 4: Reflecting projection screens — Classification and measurement of reflected screen luminance levels and sound attenuation*
- *Part 5: Viewing conditions of transparent and reflecting screens*

Annex A of this part of ISO 11315 is for information only.
<https://standards.iteh.ai/catalog/standards/sist/2f8fa502-290f-4e7d-b0de-2a1da94ea2ae/iso-11315-3-1999>

© ISO 1999

All rights reserved. Unless otherwise specified, no part of this publication may be reproduced or utilized in any form or by any means, electronic or mechanical, including photocopying and microfilm, without permission in writing from the publisher.

International Organization for Standardization
Case postale 56 • CH-1211 Genève 20 • Switzerland
Internet iso@iso.ch

Printed in Switzerland

Photography — Projection in indoor rooms —

Part 3:

Classification of transmitting projection screens and measurement of their transmitted luminance levels

1 Scope

This part of ISO 11315 specifies the classification of transmitting projection screens for indoor applications, and describes the methods and parameters for measuring the transmitted screen luminance.

It describes measurements and anticipated data that should be obtained in the laboratory prior to actual selection and installation of the screen.

NOTE A complete classification of reflecting projection screens is standardized in ISO 11315-4.

iTeh STANDARD PREVIEW
(standards.iteh.ai)

2 Normative references

The following normative documents contain provisions which, through reference in this text, constitute provisions of this part of ISO 11315. For dated references, subsequent amendments to, or revisions of, any of these publications do not apply. However, parties to agreements based on this part of ISO 11315 are encouraged to investigate the possibility of applying the most recent editions of the normative documents indicated below. For undated references, the latest edition of the normative document referred to applies. Members of ISO and IEC maintain registers of currently valid International Standards.

ISO 2910:1990, *Cinematography — Screen luminance for the projection of motion-picture prints in indoor theatres and review rooms.*

ISO 11315-1:1997, *Photography — Projection in indoor rooms — Part 1: Screen illumination test for still projectors.*

ISO 11315-2:1997, *Photography — Projection in indoor rooms — Part 2: Screen luminance test for still and video projection.*

ISO 11315-4:—¹⁾, *Photography — Projection in indoor rooms — Part 4: Reflecting projection screens — Classification and measurement of reflected screen luminance levels and sound attenuation.*

CIE No. 15.2:1986, *Colorimetry (2nd edition).*

CIE No. 17.4:1987, *International Lighting Vocabulary [IEC 50 (845): International Electrotechnical Vocabulary, Chapter 845: Lighting].*

CIE No. 38:1977, *Radiometric and Photometric Characteristics of Materials and their Measurement.*

CIE No. 69:1987, *Methods of Characterizing Illuminance Meters and Luminance Meters — Performance, Characteristics and Specifications.*

¹⁾ To be published.

3 Term and definition

For the purposes of this part of ISO 11315, the following term and definition applies.

3.1 luminance factor

ratio of the luminance of the test screen at a given viewing angle and the luminance of an identically illuminated tablet of pressed barium sulfate powder

4 Classification of transmitting projection screens, projection properties and comparison specimens

4.1 Rear projection screen-type R

Transmitting projection screens are classified according to their transmission characteristics. Regarding screens of type R, two subtypes (see Table 1), which differ in their structure, shall be distinguished according to the latest technological developments.

The common code name is type R. They are intended for rear projection only, and scatter the incident light over a wide area. The preferred angle of transmission follows the direction of incident light.

NOTE The material used may be synthetic foils or glass. These screens are also referred to in the trade as back-projection screens.

iTeh STANDARD PREVIEW
Table 1 — Types of transmitting projection screens
 (standards.iteh.ai)

Projection screen type	Production method	Distinguishing characteristics	See subclause
R-O (opalized)	In rigid plates or flexible plastic foils	"Hot spot" is possible	4.1.1
R-S (structured surface)	In rigid plates only	Optimum luminance factor indicatrix in horizontal and vertical direction, possibility of suppression of negative influences by the room light	4.1.2

Even illumination of the whole screen surface is required.

4.1.1 Rear projection screen-type R-O

The screen-type R-O has an opalescent characteristic. It can either have a one-sided or double-sided matted surface or the mostly clear base material (support) gets a supplement, for example through foreign polymers, through which the diffusive effect is produced. Combined versions are possible.

The screen-type R-O does not possess a surface structure. It can be produced in flexible foils as well as in solid plastic or glass plates.

The production method does not restrict the dimensions of the screen.

4.1.2 Rear projection screen-type R-S

The screen-type R-S has either a one-sided or a double-sided structured surface which allows a better distribution of light. Examples are fresnel lenses, lenticular lens or prism arrangements.

Moreover, the screen-type R-S contains diffusive additions on or in the base material in order to produce projected pictures. The screen-type R-S with fresnel lenses can only be delivered by rigid plastic plates in fixed sizes. Furthermore, this version necessitates observing a projection distance that is determined by the fresnel lens.

4.1.3 Hot spot (increased transmission near the projection axis)

This interference can occur with all screen-types R, independently of the surface structure. A remedy is possible through diffusive additions on or in the base material.

4.1.4 Screen-type R in multilayer construction

Due to the potential difference of the single layers, multilayer construction can cause technological lighting interference phenomena; i.e. during the projection as scintillation in all colours of the spectrum, as Newton's rings, or as a moiré-effect. The screen-type R can also produce "cloud-formation" through irregularities in the distribution of light.

In borderline cases, multilayer construction can result in a separation of the single layers, i.e. longer storage in an inclined position can produce this effect.

NOTE "Sandwich-screen" is a slang technical term, but it is used in practice.

4.1.5 Use of the screen-type R in a "dark room" or an "illuminated room"

If rear projection is carried out in a "dark room" (dark viewing area), the diffusive additions on or in the base material should only be a small part, through which the transmission characteristics of the screen are increased. (The screen appears "bright".)

In the case of rear projection carried out in an "illuminated room" (viewing area is illuminated), the diffusive additions on or in the base have to be increased. For this reason, the transmission characteristics decrease, but at the same time the reflection of ambient light from the viewing side of the screen is greatly reduced. Placing small black stripes (black matrix) or a matted surface on the screen-side of the viewer avoids this effect. (The screen appears "dark".)

NOTE The interfering light, which affects the side that faces the projector, reduces the recognizability of the projected picture, particularly with the screen-type R-S having a fresnel-lens structure. The screening of the projection light-beam remedies the interfering light.

5 Measurement of transmitted luminance levels

5.1 General

Measurements shall be made of samples of the screen material up to size A4 (210 mm × 297 mm, nominal) for easier filing of the samples. The incident projection light shall be normal to the screen surface, without film in the gate and confined within a full beam angle of not more than 5°. It shall illuminate the entire sample of the test screen. The luminance shall be measured with a luminance meter.

The luminance meter shall have a measurement field angle²⁾ of not greater than 2° and a spectral response²⁾ of a standard observer as adopted by the International Commission on Illumination in 1924, and adopted in 1933 by the International Committee of Weights and Measures, and documented in CIE No. 15.2.

The tolerance (f_1') of the match of the relative spectral response of the luminance meter to the $V(\lambda)$ function given in CIE Publication 69, shall be $f_1' = 3\%$.

²⁾ CIE No. 38.

5.2 Measurement of transmission luminance level for opalized and structured transmitting screens

A general arrangement for the system of measurement is shown in Figure 1.

The projector shall be placed according to the screen manufacturer’s recommendation (i.e. $3 \times w$); and the distance shall be listed in the report.

The luminance factor shall be measured in the centre of the test screen.

The distance from the screen to the luminance meter shall be three times the width of the transmitting screen.

NOTE The distance of three times the width of the screen is a fundamental value for best legibility of details and good perception (overlook) of the whole image during the viewing of projection.

Measurements shall be made as follows. Measure the luminance on the projector side of the test screen to the standard of a BaSO₄ tablet, and measure the luminance on the viewing side of the test screen with the same illumination and the same angles. These measurements shall be taken at 10°, 15°, 20°, 25°, 30°, 35°, 40°, 45° and 50° to both sides of a horizontal line from the centre of the screen and normal to the plane of the screen (i.e. a total of 20 measurements). A second set of measurements shall be made in a plane that is vertical and bisects the screen. These measurements shall be taken at 5°, 10°, 15° and 20° to both sides of a vertical line from the centre of the screen and normal to the plane of the screen (i.e. a total of 8 measurements).

The luminance factor of the test screen (β_{TM}) is obtained from the following formula:

$$\beta_{TM} = \frac{L_{TM}}{L_{BaSO_4}}$$

iTeh STANDARD PREVIEW
(standards.iteh.ai)

where

- β_{TM} is the luminance factor of test screen;
- L_{TM} is the luminance measured to test screen from viewing side;
- L_{BaSO_4} is the luminance measured to tablet of BaSO₄ from projector side.

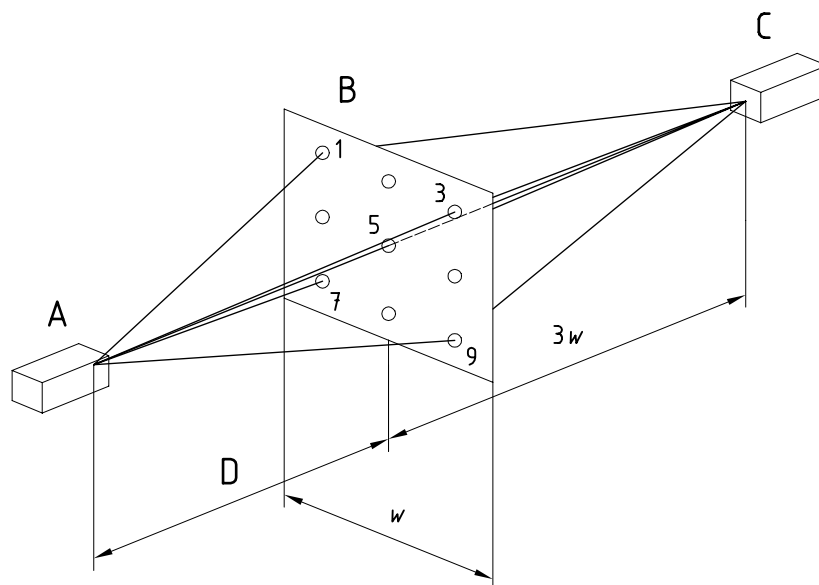

Key

- | | | | | | |
|---|--------------|---|---------------------------------------|---------|---------------|
| w | Screen width | C | Luminance meter | 1/3/7/9 | corner points |
| A | Projector | D | Distance according to screen producer | 5 | centre point |
| B | Screen | | | | |

Figure 1 — General arrangement for system of measurement

For the measurement of the luminance factor in the horizontal direction, the reference system is given in Figure 2. The position of the luminance meter shall be changed in the left and in the right direction.

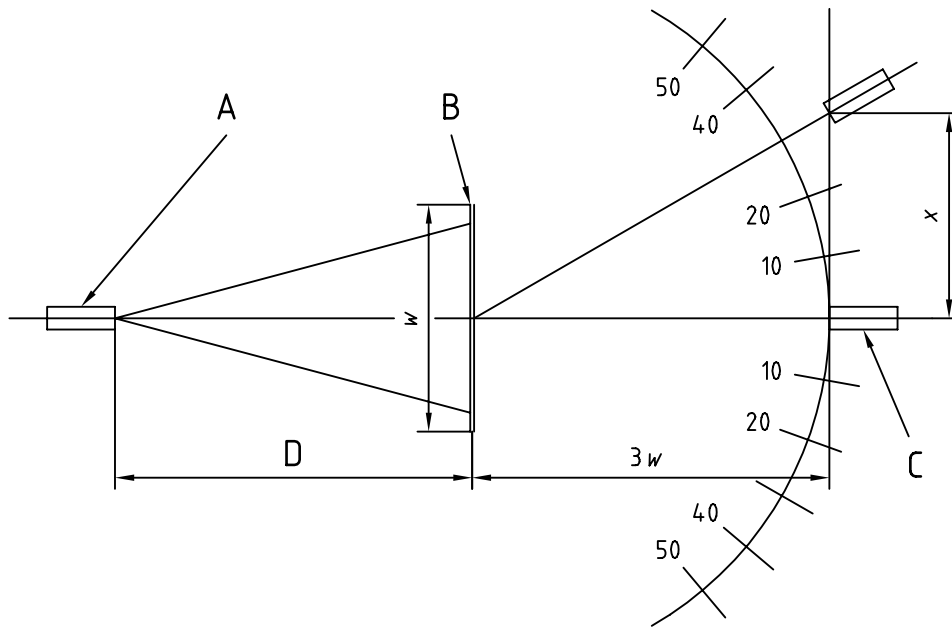

Key

- | | | | | | |
|---|--------------|---|-----------------|---|---------------------------------------|
| w | Screen width | B | Screen | D | Distance according to screen producer |
| A | Projector | C | Luminance meter | | |

Figure 2 — System of measuring in horizontal direction, minimum angle of measurement 40° to both sides of the centreline

For the measurement of the luminance factor in the vertical direction, the reference system is given in Figure 3. The position of the luminance meter shall be changed in the up and in the down direction.

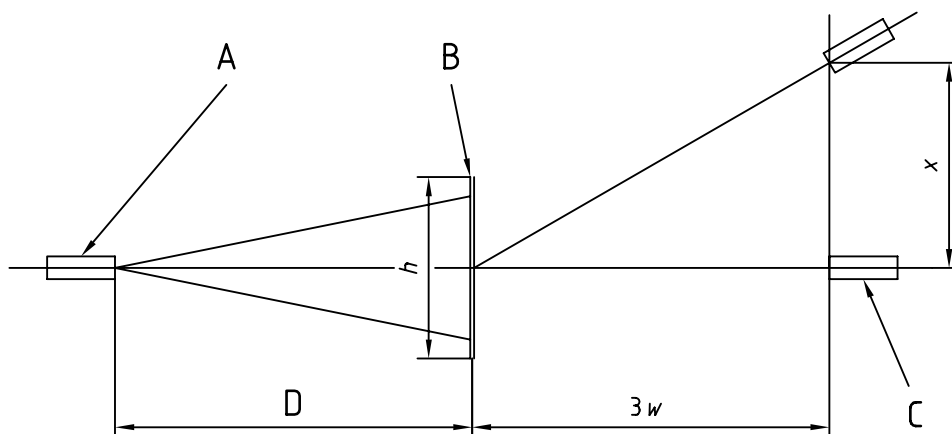

Key

- | | | | | | |
|---|---------------|---|-----------|---|---------------------------------------|
| w | Screen width | A | Projector | C | Luminance meter |
| h | Screen height | B | Screen | D | Distance according to screen producer |

Figure 3 — System of measuring in vertical direction

5.3 Measurement of the uniformity of luminance distribution g_2 for structured transmitting screens

The system of measurement corresponds to Figures 1, 4 and 5.

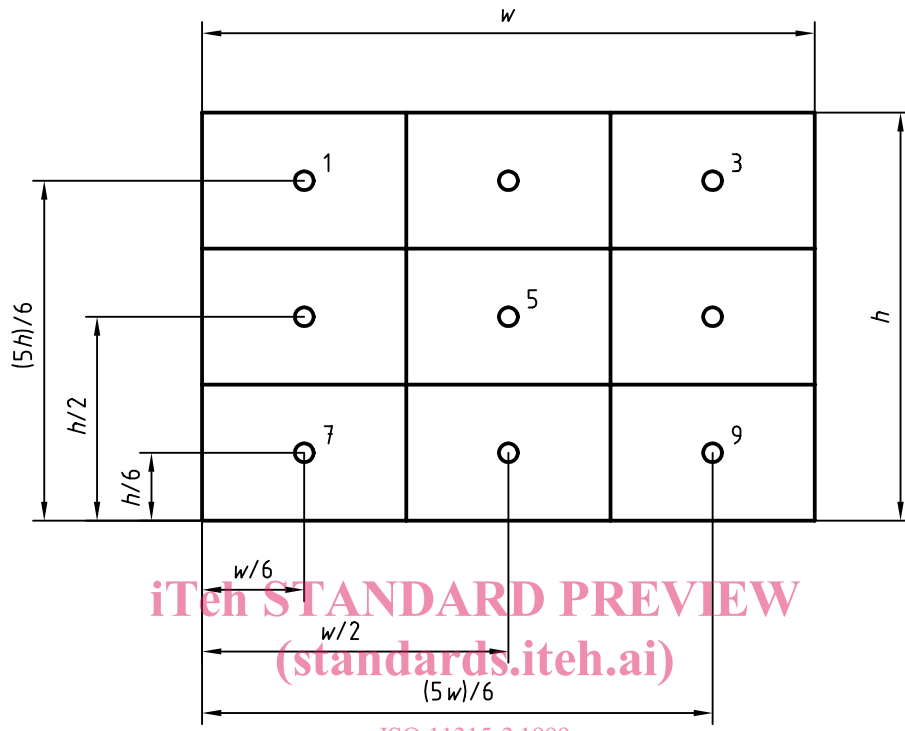

iTeH STANDARD PREVIEW
(standards.iteh.ai)

ISO 11315-3:1999

<https://standards.iteh.ai/catalog/standards/sist/2f8fa502-290f-4e7d-b0de-2a1da94ea2ac/iso-11315-3-1999>

Key

- w Screen width
- h Screen height

Figure 4 — Position of test points on the screen

Before recording the luminance factor indicatrix, the projector used for the measurement shall be tested as specified in ISO 11315-1.

The luminance L shall be measured from the viewing side to the five test points (1, 3, 7, 9 and 5). The position of the luminance meter shall be in the optical axis and the distance to the test screen shall be three times the width, w , of the screen.

During the measurement of the corner test points 1, 3, 7 and 9, the luminance meter in the optical axis shall be tilted towards the position of the four measured corner test points (see Figure 5).

The illuminance E shall be measured on the test screen of the projector side at the same five test points. The sensor of the illuminance meter shall be parallel to the surface of the screen, and the maximum distance shall be 20 mm.

The average values of the 2×4 measurements (corner test points 1, 3, 7, 9) are L_a and E_a .

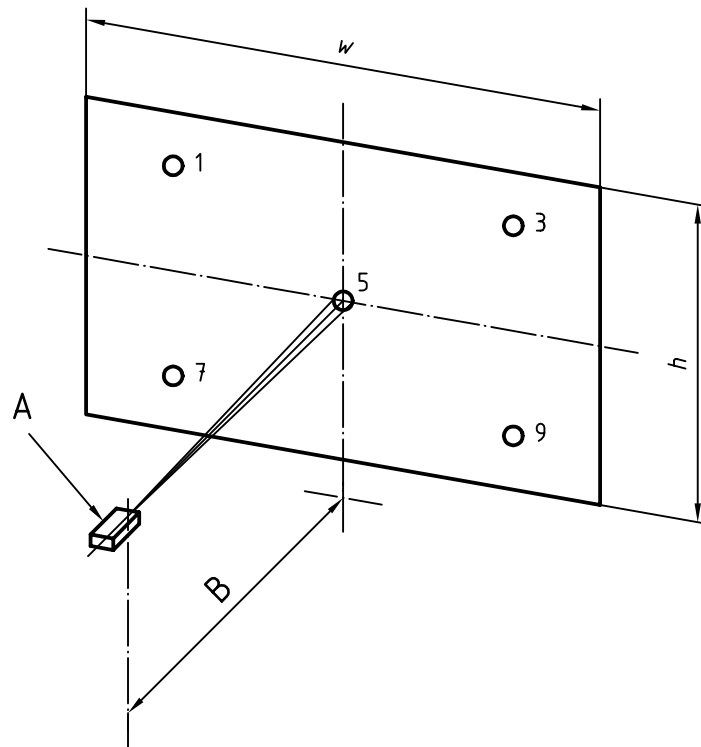
**Key**

w Screen width
 h Screen height

A Luminance meter
 B Distance $3w$

iTeh STANDARD PREVIEW
 (standards.iteh.ai)

ISO 11315-3:1999
Figure 5 — Arrangement for determining the uniformity of luminance

<https://standards.iteh.ai/catalog/standards/sist/2181a502-290f-4e7d-60de-2a1da94ea2ae/iso-11315-3-1999>

The uniformity of luminance distribution g_2 (in accordance with CIE No. 17) shall be given by the formula:

$$g_2 = \frac{L_a}{L_5} \times \frac{E_5}{E_a}$$

where

g_2 is the uniformity of luminance distribution;

L_a, E_a are the average values of luminance and illuminance;

L_5, E_5 are the measured values of luminance and illuminance at centre-point 5.

NOTE The uniformity of luminance distribution $g_2 = 80\%$, as caused by the screen, should be 80% minimum to result in a good distribution of luminance.

5.4 Presentation of data

5.4.1 Presentation in a polar diagram

The measurement data shall be presented in either Cartesian or polar diagrams, showing the relationship β_{TM} between the luminance using a perfect reflecting diffuser (preferably a tablet of pressed barium sulfate, as specified in CIE Publication 38:1977, Section 12.2.5) and the luminance of the test screen, depending on the angle between the projection and reflection beam. See Figure 6.

The luminance factors for the horizontal and the vertical distributions shall be shown in the same diagram with two different lines.