**Welding — Acceptance inspection of
electron beam welding machines —**

**Part 4:
Measurement of welding speed**

*Soudage — Essais de réception des machines de soudage par faisceau
d'électrons —*
(Partie 4: Mesure de la vitesse de soudage)

[ISO 14744-4:2000](https://standards.iso.org/standards/catalog/standards/sist/be7b5328-ee2d-4d64-850b-6c61cb8b7e55/iso-14744-4-2000)

<https://standards.iteh.ai/catalog/standards/sist/be7b5328-ee2d-4d64-850b-6c61cb8b7e55/iso-14744-4-2000>



PDF disclaimer

This PDF file may contain embedded typefaces. In accordance with Adobe's licensing policy, this file may be printed or viewed but shall not be edited unless the typefaces which are embedded are licensed to and installed on the computer performing the editing. In downloading this file, parties accept therein the responsibility of not infringing Adobe's licensing policy. The ISO Central Secretariat accepts no liability in this area.

Adobe is a trademark of Adobe Systems Incorporated.

Details of the software products used to create this PDF file can be found in the General Info relative to the file; the PDF-creation parameters were optimized for printing. Every care has been taken to ensure that the file is suitable for use by ISO member bodies. In the unlikely event that a problem relating to it is found, please inform the Central Secretariat at the address given below.

iTeh STANDARD PREVIEW
(standards.iteh.ai)

[ISO 14744-4:2000](https://standards.iteh.ai/catalog/standards/sist/be7b5328-ee2d-4d64-850b-6c61cb8b7e55/iso-14744-4-2000)

<https://standards.iteh.ai/catalog/standards/sist/be7b5328-ee2d-4d64-850b-6c61cb8b7e55/iso-14744-4-2000>

© ISO 2000

All rights reserved. Unless otherwise specified, no part of this publication may be reproduced or utilized in any form or by any means, electronic or mechanical, including photocopying and microfilm, without permission in writing from either ISO at the address below or ISO's member body in the country of the requester.

ISO copyright office
Case postale 56 • CH-1211 Geneva 20
Tel. + 41 22 749 01 11
Fax + 41 22 734 10 79
E-mail copyright@iso.ch
Web www.iso.ch

Printed in Switzerland

Foreword

ISO (the International Organization for Standardization) is a worldwide federation of national standards bodies (ISO member bodies). The work of preparing International Standards is normally carried out through ISO technical committees. Each member body interested in a subject for which a technical committee has been established has the right to be represented on that committee. International organizations, governmental and non-governmental, in liaison with ISO, also take part in the work. ISO collaborates closely with the International Electrotechnical Commission (IEC) on all matters of electrotechnical standardization.

International Standards are drafted in accordance with the rules given in the ISO/IEC Directives, Part 3.

Draft International Standards adopted by the technical committees are circulated to the member bodies for voting. Publication as an International Standard requires approval by at least 75 % of member bodies casting a vote.

Attention is drawn to the possibility that some of the elements of this part of ISO 14744 may be the subject of patent rights. ISO shall not be held responsible for identifying any or all such patent rights.

International Standard ISO 14744-4 was prepared by the European Committee for Standardization (CEN) in collaboration with ISO Technical Committee TC 44, *Welding and allied processes*, Subcommittee SC 10, *Unification of requirements in the field of metal welding*, in accordance with the Agreement on technical cooperation between ISO and CEN (Vienna Agreement).

Throughout the text of this standard, read "...this European Standard..." to mean "...this International Standard...".

ISO 14744 consists of the following parts, under the general title *Welding — Acceptance inspection of electron beam welding machines*: <https://standards.iteh.ai/catalog/standards/sist/be7b5328-ee2d-4d64-850b-6c61cb8b7e55/iso-14744-4-2000>

- *Part 1: Principles and acceptance conditions*
- *Part 2: Measurement of accelerating voltage characteristics*
- *Part 3: Measurement of beam current characteristics*
- *Part 4: Measurement of welding speed*
- *Part 5: Measurement of run-out accuracy*
- *Part 6: Measurement of stability of spot position*

Contents

	Page
Foreword	v
1 Scope	1
2 Normative reference	1
3 Test arrangement	1
3.1 Electrical test arrangement	1
3.2 Mechanical test arrangement	3
4 Measurement procedure	3
4.1 General	3
4.2 Rotation device	4
4.3 Measuring the short-term stability	4
4.4 Measuring the long-term stability	4
4.5 Measuring the reproducibility	4
5 Evaluation	5

iTeh STANDARD PREVIEW
(standards.iteh.ai)

<https://standards.iteh.ai/catalog/standards/sist/be7b5328-ee2d-4d64-850b-6c61cb8b7e55/iso-14744-4-2000>

Foreword

The text of EN ISO 14744-3:2000 has been prepared by Technical Committee CEN/TC 121 "Welding", the secretariat of which is held by DS, in collaboration with Technical Committee ISO/TC 44 "Welding and allied processes".

This European Standard shall be given the status of a national standard, either by publication of an identical text or by endorsement, at the latest by October 2000, and conflicting national standards shall be withdrawn at the latest by October 2000.

According to the CEN/CENELEC Internal Regulations, the national standards organizations of the following countries are bound to implement this European Standard: Austria, Belgium, Czech Republic, Denmark, Finland, France, Germany, Greece, Iceland, Ireland, Italy, Luxembourg, Netherlands, Norway, Portugal, Spain, Sweden, Switzerland and the United Kingdom.

This draft European Standard is composed of the six following parts:

- Part 1: Principles and acceptance conditions;
- Part 2: Measurement of accelerating voltage characteristics;
- Part 3: Measurement of beam current characteristics;
- Part 4: Measurement of welding speed;
- Part 5: Measurement of run-out accuracy;
- Part 6: Measurement of stability of spot position.

iTeh STANDARD PREVIEW (standards.iteh.ai)

[ISO 14744-4:2000](https://standards.iteh.ai/catalog/standards/sist/be7b5328-ee2d-4d64-850b-6c61cb8b7e55/iso-14744-4-2000)

<https://standards.iteh.ai/catalog/standards/sist/be7b5328-ee2d-4d64-850b-6c61cb8b7e55/iso-14744-4-2000>

iTeh STANDARD PREVIEW
(standards.iteh.ai)

ISO 14744-4:2000

<https://standards.iteh.ai/catalog/standards/sist/be7b5328-ee2d-4d64-850b-6c61cb8b7e55/iso-14744-4-2000>

1 Scope

This standard is intended for use when the welding speed for electron beam welding machines complying with EN ISO 14744-1 is to be measured in connection with an acceptance inspection. It provides essential information on the procedure and apparatus to be used for making the measurements.

Alternative standardised procedures can be used, provided they have at least the same acceptance inspection as the welds specified in this part 4. The measured parameter is the speed of the translational and rotational movements required to perform the welding operation.

The welding speed is one of the significant parameters in electron beam welding. The workpiece or the weld point shall thus be moved at a uniform speed, in a reproducible manner, within given short-term and long-term limits. The purpose of the measurement is to check whether the variations in welding speed are maintained within these limits.

2 Normative reference

This European Standard incorporates by dated or undated reference, provisions from other publications. These normative references are cited at the appropriate places in the text and the publications are listed hereafter. For dated references, subsequent amendments to or revisions of any of these publications apply to this European Standard only when incorporated in it by amendment or revision. For undated references the latest edition of the publication referred to applies (including amendments).

EN ISO 14744-1:2000

Welding – Acceptance inspection of electron beam welding machines – Part 1: Principles and acceptance conditions (ISO 14744-1:2000)

ITh STANDARD PREVIEW
(standards.iteh.ai)

3 Test arrangement

3.1 Electrical test arrangement

[ISO 14744-4:2000](https://standards.iteh.ai/catalog/standards/sist/be7b5328-ee2d-4d64-850b-6c61cb8b7e55/iso-14744-4-2000)

[https://standards.iteh.ai/catalog/standards/sist/be7b5328-ee2d-4d64-850b-](https://standards.iteh.ai/catalog/standards/sist/be7b5328-ee2d-4d64-850b-6c61cb8b7e55/iso-14744-4-2000)

[6c61cb8b7e55/iso-14744-4-2000](https://standards.iteh.ai/catalog/standards/sist/be7b5328-ee2d-4d64-850b-6c61cb8b7e55/iso-14744-4-2000)

To take account of all interferences affecting the welding speed, the measurement shall be made directly on the workpiece or on the device positioning the workpiece or on a movable electron gun, if appropriate. Suitable transducers, with a linear response, may be used to transmit the translational or rotational movement, e.g. rotary transducers, via a hard rubber friction wheel (see figures 1 and 2).

Build-in encoders or resolvers may also be used, if directly connected to the moving devices.

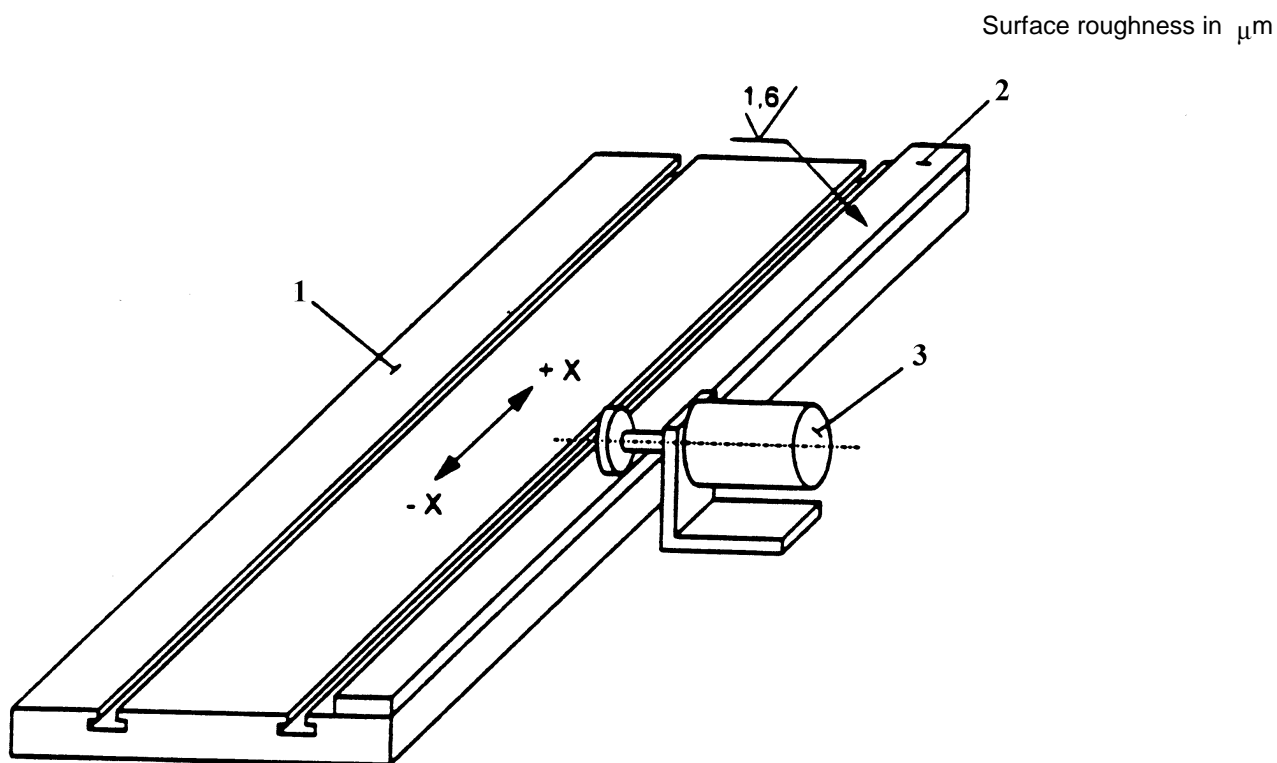

iTeh STANDARD PREVIEW
(standards.iteh.ai)

Key

- 1 Work table
- 2 Contact strip
- 3 Rotary transducer fixed to non-moving part

[ISO 14744-4:2000](https://standards.iteh.ai/catalog/standards/sist/be7b5328-ee2d-4d64-850b-)

<https://standards.iteh.ai/catalog/standards/sist/be7b5328-ee2d-4d64-850b->

Figure 1 - Example of arrangement for measuring the speed of translational movements

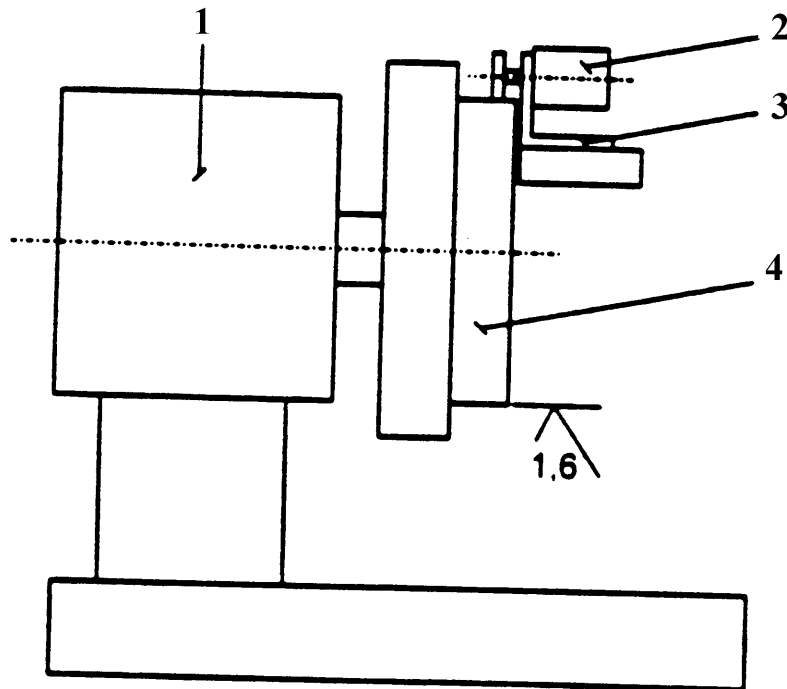
Surface roughness in μm **Key**

- 1 Rotating device
- 2 Rotary transducer
- 3 Flexible metal angle fixed to non-moving part
- 4 Contact ring

iTeh STANDARD PREVIEW
(standards.iteh.ai)

ISO 14744-4:2000

<https://standards.iteh.ai/catalog/standards/sist/be7b5328-ee2d-4d64-850b-6c61c6807c55/iso-14744-4-2000>
Figure 2 - Example of arrangement for measuring the speed of rotational movements

3.2 Mechanical test arrangement

A special support has to be used to effect mechanical contact between transducer and the device positioning the workpiece.

For greater accuracy of measurement, this special support has to fulfill the following requirements:

- a) it shall keep the transducer firmly in place with minimum vibration, e.g. on the work table supporting structure or on the work chamber. In some cases, multiaxial support of the transducer might be necessary;
- b) it shall allow for a certain yield in the contact between friction wheel and contact surface, e.g. by means of a resilient metal angle (see figure 2). Any slip occurring is at once evident in the measurement and can be compensated for by slightly increasing the pressure application.

Rotary transducers may also be used for speed measurements under vacuum. Relevant information may be obtained from the manufacturer of the transducer. For such measurement, a feed-through to accommodate a multi-core cable is required for connecting the transducer and the frequency-voltage converter.

4 Measurement procedure

4.1 General

The measurements shall be carried out with the welding machine set as specified in 6.3 of EN ISO 14744-1:2000.

Unless otherwise specified the measurements may be carried out with the chamber vented.