DfYg_i ýUb^YVf]n[UbY[UVYfcbUË&"XY. H'U bUfXbcghgj YýY[UVf]n[UbY[U
VYfcbU

Testing sprayed concrete - Part 2: Compressive strength of young sprayed concrete

Prüfung von Spritzbeton - Teil 2: Druckfestigkeit von jungem Spritzbeton

Essais pour béton projeté - Partie 2: Résistance à la compression au jeune âge du
béton projeté

(standards.iteh.ai)

Ta slovenski standard je istoveten z: EN 14488-2:2006

<https://standards.iteh.ai/catalog/standards/sist/592a9089-f94d-4024-aed1-52160d96a8fb/sist-en-14488-2-2006>

ICS:

91.100.30	Beton in betonski izdelki	Concrete and concrete products
-----------	---------------------------	--------------------------------

SIST EN 14488-2:2006

en

iTeh STANDARD PREVIEW
(standards.iteh.ai)

SIST EN 14488-2:2006

<https://standards.iteh.ai/catalog/standards/sist/592a9089-f94d-4024-aed1-52160d96a8fb/sist-en-14488-2-2006>

ICS 91.100.30

English Version

Testing sprayed concrete - Part 2: Compressive strength of young sprayed concrete

Essais pour béton projeté - Partie 2 : Résistance à la compression au jeune âge du béton projeté

Prüfung von Spritzbeton - Teil 2: Druckfestigkeit von jungem Spritzbeton

This European Standard was approved by CEN on 3 May 2006.

CEN members are bound to comply with the CEN/CENELEC Internal Regulations which stipulate the conditions for giving this European Standard the status of a national standard without any alteration. Up-to-date lists and bibliographical references concerning such national standards may be obtained on application to the Central Secretariat or to any CEN member.

This European Standard exists in three official versions (English, French, German). A version in any other language made by translation under the responsibility of a CEN member into its own language and notified to the Central Secretariat has the same status as the official versions.

CEN members are the national standards bodies of Austria, Belgium, Cyprus, Czech Republic, Denmark, Estonia, Finland, France, Germany, Greece, Hungary, Iceland, Ireland, Italy, Latvia, Lithuania, Luxembourg, Malta, Netherlands, Norway, Poland, Portugal, Romania, Slovakia, Slovenia, Spain, Sweden, Switzerland and United Kingdom.

[SIST EN 14488-2:2006](https://standards.iteh.ai/catalog/standards/sist/592a9089-f94d-4024-aed1-52160d96a8fb/sist-en-14488-2-2006)

<https://standards.iteh.ai/catalog/standards/sist/592a9089-f94d-4024-aed1-52160d96a8fb/sist-en-14488-2-2006>



EUROPEAN COMMITTEE FOR STANDARDIZATION
COMITÉ EUROPÉEN DE NORMALISATION
EUROPÄISCHES KOMITEE FÜR NORMUNG

Management Centre: rue de Stassart, 36 B-1050 Brussels

Contents

Foreword.....	3
1 Scope	4
2 Principle.....	4
2.1 General.....	4
2.2 Method A: Penetration needle	4
2.3 Method B: Stud driving	4
3 Apparatus	4
3.1 Method A: Penetration needle	4
3.2 Method B: Stud driving	4
4 Test specimen	5
5 Procedures	5
5.1 Method A: Penetration needle	5
5.2 Method B: Stud driving	5
6 Expression of results	7
6.1 Method A: Penetration needle	7
6.2 Method B: Stud driving	7
7 Test report	8
7.1 Method A: Penetration needle	8
7.2 Method B: Stud driving	8
8 Precision.....	8
Annex A (informative) Example of calibration curves for needle penetrometer	9
Annex B (informative) Example of calibration curves for stud driver	10

ITeCh STANDARD PREVIEW

(standards.itech.ai)

SIST EN 14488-2:2006

[https://standards.itech.ai/catalog/standards/sist/592a9089-d4d-4024-acd1-](https://standards.itech.ai/catalog/standards/sist/592a9089-d4d-4024-acd1-52160d96a8fb/sist-en-14488-2-2006)

[52160d96a8fb/sist-en-14488-2-2006](https://standards.itech.ai/catalog/standards/sist/592a9089-d4d-4024-acd1-52160d96a8fb/sist-en-14488-2-2006)

Foreword

This document (EN 14488-2:2006) has been prepared by Technical Committee CEN/TC 104 “Concrete and related products”, the secretariat of which is held by DIN.

This European Standard shall be given the status of a national standard, either by publication of an identical text or by endorsement, at the latest by December 2006, and conflicting national standards shall be withdrawn at the latest by December 2007.

This series EN 14488 ‘Testing sprayed concrete’ includes the following parts:

- Part 1: Sampling fresh and hardened concrete
- Part 2: Compressive strength of young sprayed concrete
- Part 3: Flexural strengths (first peak, ultimate and residual) of fibre reinforced beam specimens
- Part 4: Bond strength of cores by direct tension
- Part 5: Determination of energy absorption capacity of fibre reinforced slab specimens
- Part 6: Thickness of concrete on a substrate
- Part 7: Fibre content of fibre reinforced concrete

According to the CEN/CENELEC Internal Regulations, the national standards organizations of the following countries are bound to implement this European Standard: Austria, Belgium, Cyprus, Czech Republic, Denmark, Estonia, Finland, France, Germany, Greece, Hungary, Iceland, Ireland, Italy, Latvia, Lithuania, Luxembourg, Malta, Netherlands, Norway, Poland, Portugal, Romania, Slovakia, Slovenia, Spain, Sweden, Switzerland and United Kingdom.

1 Scope

This part specifies two methods from which an estimate of the in situ compressive strength of young hardened sprayed concrete can be made.

2 Principle

2.1 General

The strength development of young sprayed concrete is assessed in the ranges of 0,2 MPa to 1,2 MPa and 3 MPa to 16 MPa respectively with Method A and Method B.

2.2 Method A: Penetration needle

This method is used to measure the force required to push a needle of specified dimensions to penetrate into the sprayed concrete to a depth of 15 mm +/- 2 mm. A penetrometer indicates the resisting force, through compression of a calibrated spring from which an estimated compressive strength can be derived from a conversion curve, to be provided by the producer of the test equipment.

2.3 Method B: Stud driving

A stud is driven into the sprayed concrete and the depth of penetration is determined. The stud is then extracted and the pull-out force measured. The ratio of pull-out force to penetration depth can be used to obtain an estimated compressive strength from a conversion curve, to be provided by the producer of the test equipment.

3 Apparatus

[SIST EN 14488-2:2006
https://standards.iteh.ai/catalog/standards/sist/592a9089-f94d-4024-aed1-52160d96a8fb/sist-en-14488-2-2006](https://standards.iteh.ai/catalog/standards/sist/592a9089-f94d-4024-aed1-52160d96a8fb/sist-en-14488-2-2006)

3.1 Method A: Penetration needle

3.1.1 Penetrometer, capable of driving the needle into the surface and recording the force required to an accuracy of 10 N. The penetrometer shall be provided with a certified calibration curve, able to correlate readings to estimated compressive strength. An example of calibration curves is shown in Annex A.

3.1.2 Needle with a diameter of 3 mm +/- 0,1 mm and a tip with a taper angle of (60 +/- 5)°.

3.1.3 Test protocol form to record all test data.

3.2 Method B: Stud driving

3.2.1 Stud driving equipment to insert the stud into the sprayed concrete.

The stud installer should be capable of percussively firing the stud into the concrete to a depth of at least 20 mm using proprietary equipment which has been calibrated to read compressive strength.

3.2.2 Pull-out equipment, capable of applying a tensile force to the rod with the reaction being transmitted to the concrete surface through a bearing ring.

The loading system shall ensure that the bearing ring is concentric with the rod and that the load is applied perpendicularly to the plane of the stud.

The loading system shall include a means of indicating the maximum force applied to an accuracy of 5 %. The dial, scale or display shall have a device which shall permit the recording of the maximum applied force.

3.2.3 Test protocol form to record all test data.

NOTE Other apparatus is allowed provided that it gives the required performance, or it is possible to correlate its performance to that required by the present standard.

4 Test specimen

No special test specimen is required. The testing procedure can be used for measurements at any location without advance preparation.

A sprayed concrete layer of no less than 100 mm thickness is required for testing.

5 Procedures

5.1 Method A: Penetration needle

Record time and place of completion of spraying and start of testing.

Ensure the force indicator is set to zero.

Apply the device perpendicularly to the surface of the sprayed concrete layer and steadily push in the needle to a depth of 15 mm in a single continuous movement. If this is prevented, for instance because of a large aggregate particle or reinforcement, then discontinue the test and repeat in an adjacent location.

Read the resistance force from the scale, record the value on the protocol form and return indicator to original position.

Clean the needle if necessary.

Repeat the test ten times as quickly as possible (and within 1 min for strengths below 0,5 MPa) in an area representative of the sprayed region.

Record the time at which the testing is finished (on protocol form).

5.2 Method B: Stud driving

Load the stud driving equipment according to the manufacturer's instructions.

Apply the equipment to the surface of the sprayed concrete and drive in the stud. If the longest stud penetrates fully, wait for some time and repeat when the concrete is harder. Do not drive the thread into the sprayed concrete. If the projecting stud is too long (penetration depth < 20 mm), use a shorter stud. Repeat to insert a total of 10 studs, keeping sufficient distance (> 80 mm) between the studs. Figure 1 illustrates the distance between studs referring to the test panel.

Dimensions in millimetres

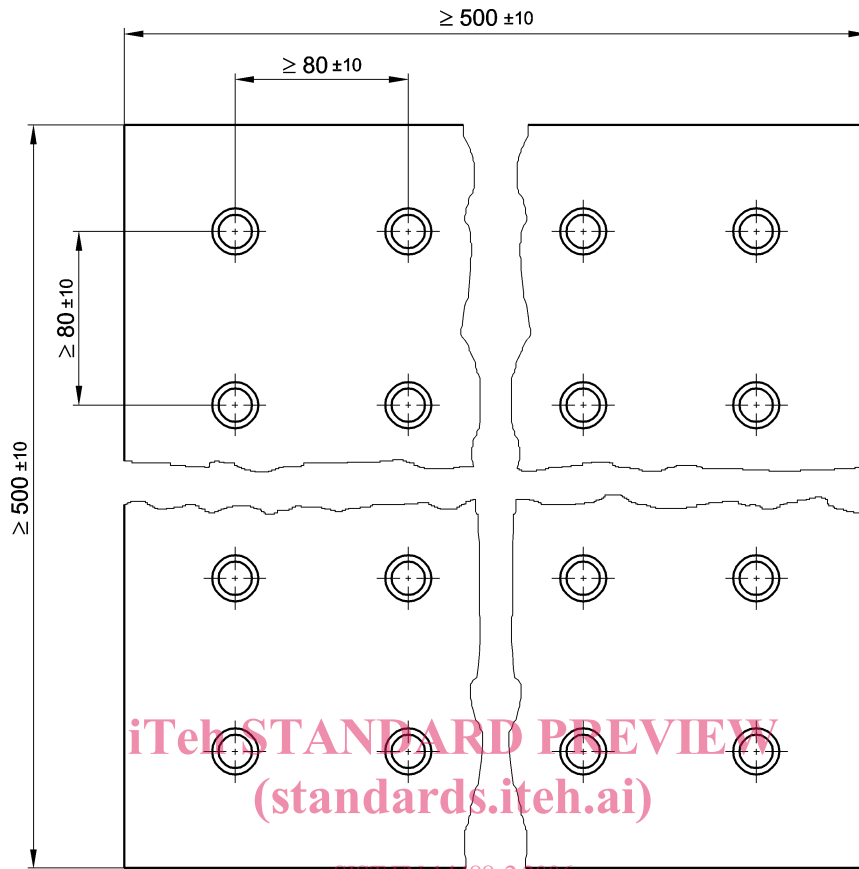

SIST EN 14488-2:2006
<https://standards.iteh.ai/catalog/standards/sist/592a9089-f94d-4024-aed1-52160d9c88/sist-en-14488-2-2006>
Figure 1 — Distance between studs

Ensure that the studs do not penetrate the substrate by selection of an appropriate combination of stud length and/or cartridge.

Measure the projecting length of the stud and record it on the test protocol form (see example in figure 2).

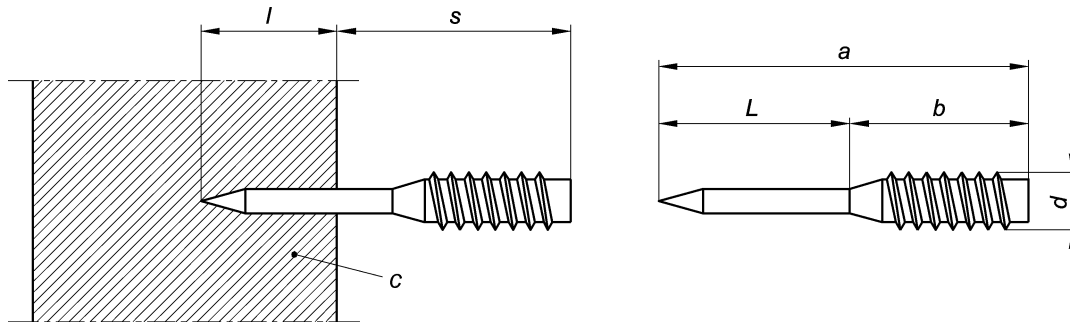

Key

l Penetration depth

s Protrusion of the stud from concrete

c Concrete

a Total length

L stem length

b thread length

d thread width

Figure 2 Example for the definition of the stem and of the depth of stud penetration

Determine the penetration depths of the studs on the test protocol form.

Fasten pull-out equipment to the threaded end of the studs and extract in the same order as during insertion.

Record the pull-out force of each stud and the time of the start and end of testing of the 10 studs on the test protocol form.

Correct each pull-out force using the calibration curve supplied with the equipment. An example of calibration curves is shown in Annex B.

Determine the ratio of the pull-out force (P) to penetration length (l) for each stud.

6 Expression of results

6.1 Method A: Penetration needle

Calculate the mean resistance force from the 10 measurements.

If required derive the estimated compressive strength from the manufacturer's conversion curve.

Extrapolation is not permitted.

6.2 Method B: Stud driving

Calculate the mean corrected pull-out force (using the calibration curve supplied with the equipment) from the 10 measurements.

If required estimate the compressive strength on the basis of the mean P/l using the manufacturer's conversion curve. Extrapolation is not permitted.