



SLOVENSKI STANDARD

SIST ISO 3547-3:2002

01-marec-2002

Drсни ležaji - Zvite puše - 3. del: Luknje za mazanje, utori za mazanje in odtisnjeni žepki za mazanje

Plain bearings -- Wrapped bushes -- Part 3: Lubrication holes, lubrication grooves and lubrication indentations

iTeh STANDARD PREVIEW

Paliers lisses -- Bagues roulées -- Partie 3: Trous de graissage, rainures de graissage et creux de graissage

[SIST ISO 3547-3:2002](https://standards.itih.ai/catalog/standards/sist/518ea334-d5eb-430a-b115-15713767bccd/sist-iso-3547-3-2002)

Ta slovenski standard je istoveten z: ISO 3547-3:1999

ICS:

21.100.10	Drсни ležaji	Plain bearings
21.260	Mazalni sistemi	Lubrication systems

SIST ISO 3547-3:2002

en

iTeh STANDARD PREVIEW
(standards.iteh.ai)

SIST ISO 3547-3:2002

<https://standards.iteh.ai/catalog/standards/sist/518ea334-d5eb-430a-b115-f57b3767bccd/sist-iso-3547-3-2002>

INTERNATIONAL STANDARD

ISO
3547-3

First edition
1999-12-01

Plain bearings — Wrapped bushes —

Part 3:

Lubrication holes, lubrication grooves and
lubrication indentations

Paliers lisses — Bagues roulées
Partie 3: Trous de graissage, rainures de graissage et creux de graissage
(standards.iteh.ai)

[SIST ISO 3547-3:2002](https://standards.iteh.ai/catalog/standards/sist/518ea334-d5eb-430a-b115-f57f3767bccd/sist-iso-3547-3-2002)

[https://standards.iteh.ai/catalog/standards/sist/518ea334-d5eb-430a-b115-
f57f3767bccd/sist-iso-3547-3-2002](https://standards.iteh.ai/catalog/standards/sist/518ea334-d5eb-430a-b115-f57f3767bccd/sist-iso-3547-3-2002)



Reference number
ISO 3547-3:1999(E)

ISO 3547-3:1999(E)

Foreword

ISO (the International Organization for Standardization) is a worldwide federation of national standards bodies (ISO member bodies). The work of preparing International Standards is normally carried out through ISO technical committees. Each member body interested in a subject for which a technical committee has been established has the right to be represented on that committee. International organizations, governmental and non-governmental, in liaison with ISO, also take part in the work. ISO collaborates closely with the International Electrotechnical Commission (IEC) on all matters of electrotechnical standardization.

International Standards are drafted in accordance with the rules given in the ISO/IEC Directives, Part 3.

Draft International Standards adopted by the technical committees are circulated to the member bodies for voting. Publication as an International Standard requires approval by at least 75 % of the member bodies casting a vote.

International Standard ISO 3547-3 was prepared by Technical Committee ISO/TC 123, *Plain bearings*, Subcommittee SC 3, *Dimensions, tolerances and construction details*.

This first edition of ISO 3547-3, together with ISO 3547-1, ISO 3547-2 and ISO 3547-4, cancels and replaces ISO 3547:1976 the technical content of which has been revised and augmented.

ISO 3547 consists of the following parts, under the general title *Plain bearings — Wrapped bushes*:

— Part 1: *Dimensions*

— Part 2: *Test data for outside and inside diameter*

— Part 3: *Lubrication holes, lubrication grooves and lubrication indentations*

— Part 4: *Materials*

iTeh STANDARD PREVIEW
(standards.iteh.ai)

SIST ISO 3547-3:2002
<https://standards.iteh.ai/catalog/standards/sist/518ea334-d5eb-430a-b115-f57b3767bccd/sist-iso-3547-3-2002>

© ISO 1999

All rights reserved. Unless otherwise specified, no part of this publication may be reproduced or utilized in any form or by any means, electronic or mechanical, including photocopying and microfilm, without permission in writing from the publisher.

International Organization for Standardization
Case postale 56 • CH-1211 Genève 20 • Switzerland
Internet iso@iso.ch

Printed in Switzerland

Plain bearings — Wrapped bushes —

Part 3:

Lubrication holes, lubrication grooves and lubrication indentations

1 Scope

This part of ISO 3547 specifies dimensions of lubrication holes, grooves and bore indentations on wrapped bushes made of solid and multilayer bearing material for application as plain bearings.

Wrapped bushes with lubrication holes, lubrication grooves or lubrication bore indentations in accordance with this part of ISO 3547 can be ordered with dimensions in accordance with ISO 3547-1 and made from materials in accordance with ISO 3547-4.

Lubrication holes, grooves and bore indentations may be executed in the flat strip metal prior to rolling. Dimensional changes brought about by the rolling of the strip metal are permissible. Marks of lubrication grooves and bore reliefs produced by stamping may appear on the back of the bush. Small cracks in the bearing material in lubrication grooves and bore indentations are permissible, provided that no small pieces become detached.

Series C bushes in accordance with ISO 3547-1:1999 may exhibit swelling running along either side of the lubricating grooves caused by the stamping operation.

See ISO 3547-2 for details of the test data for the inside and outside diameter.

The dimensions without tolerances are for guidance only and may, like the dimensions which are not stipulated, be executed differently at the discretion of the manufacturer.

2 Normative references

The following normative documents contain provisions which, through reference in this text, constitute provisions of this part of ISO 3547. For dated references, subsequent amendments to, or revisions of, any of these publications do not apply. However, parties to agreements based on this part of ISO 3547 are encouraged to investigate the possibility of applying the most recent editions of the normative documents indicated below. For undated references, the latest edition of the normative document referred to applies. Members of ISO and IEC maintain registers of currently valid International Standards.

ISO 3547-1:1999, *Plain bearings — Wrapped bushes — Part 1: Dimensions*.

ISO 3547-2, *Plain bearings — Wrapped bushes — Part 2: Test data for outside and inside diameter*.

ISO 3547-4, *Plain bearings — Wrapped bushes — Part 4: Materials*.

ISO 4378-1, *Plain bearings — Terms, definitions and classification — Part 1: Design, bearing materials and their properties*.

3 Term and definition

For the purposes of this part of ISO 3547 the definition of a wrapped bush as given in ISO 4378-1 applies.

4 Lubrication holes

See Figures 1 and 2. Where lubrication holes are required, the hatched areas indicated in Figure 2 should be avoided as far as possible.

For dimensions see Table 1.

Type L

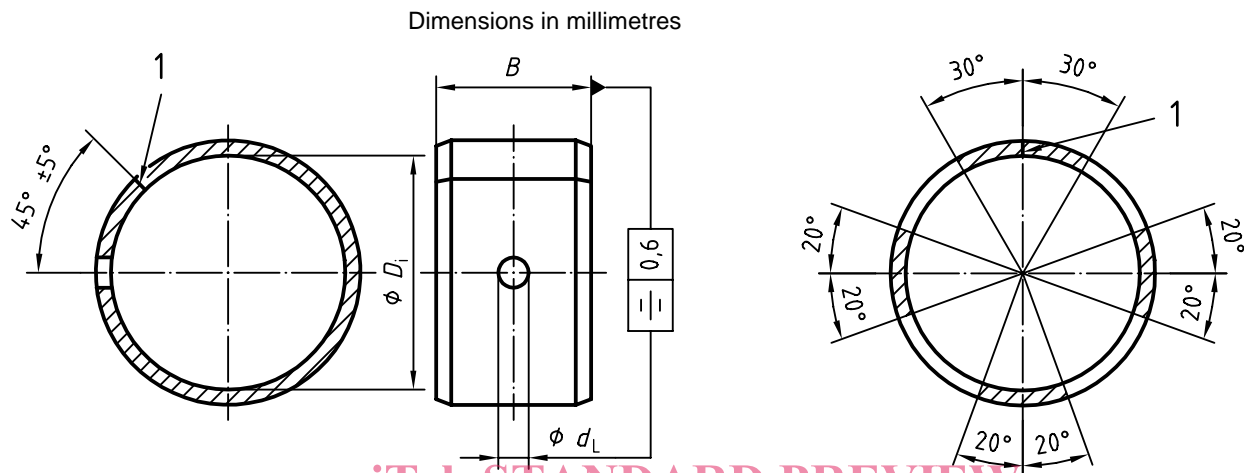

iTeh STANDARD PREVIEW
(standards.iteh.ai)

Key

1 Split

SIST ISO 3547-3:2002
<https://standards.iteh.ai/catalog/standards/sist/518ea334-d5eb-430e-f57b3767bccd/sist-iso-3547-3-2002>
 Figure 1 Figure 2

5 Lubrication grooves

Lubrication grooves type M1 and M2 are used for fluid lubrication. See Figures 3 to 6 and Tables 1 to 3.

Widening of the lubrication grooves in the area of the lubrication holes, at the split and at the end faces of the bush is permissible.

The lubrication grooves are represented on the strip metal.

NOTE In order to facilitate measurement the dimensions of the bush thickness remaining at the base of the groove may be specified on the drawing as the control dimension.

Type M1

Dimensions in millimetres

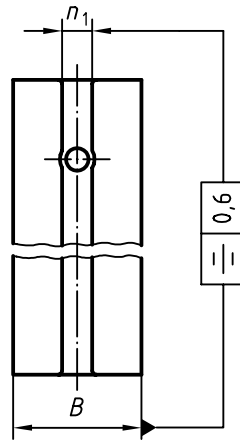

Figure 3

Table 1

iTeh STANDARD PREVIEW Dimensions in millimetres

D_i		nominal dimensions ^a	n_1	
>	≤		Series A, B, D, W	Series C
14	22	3	4	5
22	40	4	5	6
40	50	5	6	7
50	100	6	7	8
100	—	7	8	9

^a Minimum dimension after forming.

Type M2

Dimensions in millimetres

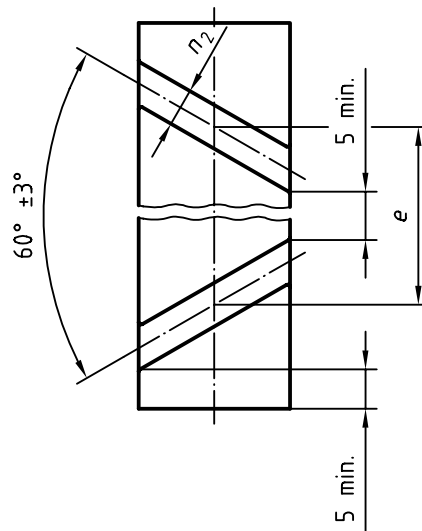

Figure 4

iTeh STANDARD PREVIEW

Table 2

(standards.iteh.ai)

Dimensions in millimetres

D_i		SIST ISO 3547-3:2002 $\pm 0,5$		e
$>$	\leq	Series A, B, D, W	Series C	
in accordance with ISO 3547-1				
18	26	3	4	32
26	36	3	4	45
36	50	5	6	70
50	70	5	6	100
70	100	6	7	130
100	—	7	8	140

Groove cross-section for Types M1 and M2 (represented on an enlarged scale)

Type M1 (2) A

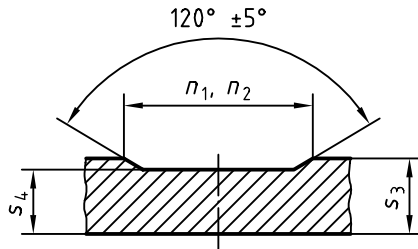

Figure 5

Type M1 (2) B

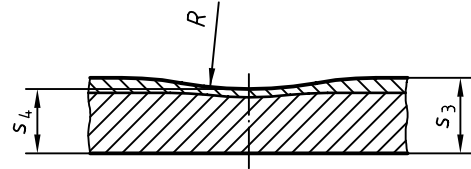

Figure 6

Table 3
iTeh STANDARD PREVIEW
(standards.itech.ai)

Dimensions in millimetres

s_3		0,75	1	1,5	2	2,5
$s_4 \begin{smallmatrix} 0 \\ -0,2 \end{smallmatrix}$	M1 (2) A	0,65	0,85	1,3	1,7	2,2
	M1 (2) B	0,7	1,1	1,6	2,1	
	R	—	6	8	10	12