



# SLOVENSKI STANDARD SIST EN 3155-044:2009

01-februar-2009

5 YfcbUj h\_U!9`Y\_f] b]\_cbhU\_h`nUi dcfUvc`j`j Ynb] `YYa Ybh] `!\$( ("XY.  
?cbhU\_h`ZY\_f] b]ža cý\_]\$( ( žhd`5 žXj c`bc`nU`f Yb]žfUhfYX`H!`GHUbXUfX`nU  
dfc]nj cX

Aerospace series - Electrical contacts used in elements of connection - Part 044:  
Contacts, electrical, male 044, type A, double crimping, class T - Product standard

Luft- und Raumfahrt - Elektrische Kontakte zur Verwendung in Verbindungselementen -  
Teil 044: Elektrischer Stiftkontakt 044, Typ A, doppelt gecrimpt, Klasse T - Produktnorm  
(standards.iteh.ai)

Série aérospatiale - Contacts électriques utilisés dans les organes de connexion - Partie  
044 : Contacts électriques, mâles 044, type A, double sertissage, classe T - Norme de  
produit  
0847f5d407e4/sist-en-3155-044-2009

Ta slovenski standard je istoveten z: EN 3155-044:2007

**ICS:**

49.060 Š`c\`æ`Á`^`[`|`b` \`æ Aerospace electric  
^|\`dã` }`æ` ]`!`^`{` æ`Á`ã`c`{`ã equipment and systems

**SIST EN 3155-044:2009** en

**iTeh STANDARD PREVIEW**  
**(standards.iteh.ai)**

SIST EN 3155-044:2009

<https://standards.iteh.ai/catalog/standards/sist/73316d52-3371-41f9-baab-0847f5d407e4/sist-en-3155-044-2009>

EUROPEAN STANDARD  
NORME EUROPÉENNE  
EUROPÄISCHE NORM

**EN 3155-044**

April 2007

ICS 49.060

English Version

**Aerospace series - Electrical contacts used in elements of  
connection - Part 044: Contacts, electrical, male 044, type A,  
double crimping, class T - Product standard**

Série aérospatiale - Contacts électriques utilisés dans les  
organes de connexion - Partie 044 : Contacts électriques,  
mâles 044, type A, double sertissage, classe T - Norme de  
produit

Luft- und Raumfahrt - Elektrische Kontakte zur Verwendung  
in Verbindungselementen - Teil 044: Elektrischer  
Stiftkontakt 044, Typ A, doppelt gecrimpt, Klasse T -  
Produktnorm

This European Standard was approved by CEN on 13 January 2006.

CEN members are bound to comply with the CEN/CENELEC Internal Regulations which stipulate the conditions for giving this European Standard the status of a national standard without any alteration. Up-to-date lists and bibliographical references concerning such national standards may be obtained on application to the CEN Management Centre or to any CEN member.

This European Standard exists in three official versions (English, French, German). A version in any other language made by translation under the responsibility of a CEN member into its own language and notified to the CEN Management Centre has the same status as the official versions.

CEN members are the national standards bodies of Austria, Belgium, Bulgaria, Cyprus, Czech Republic, Denmark, Estonia, Finland, France, Germany, Greece, Hungary, Iceland, Ireland, Italy, Latvia, Lithuania, Luxembourg, Malta, Netherlands, Norway, Poland, Portugal, Romania, Slovakia, Slovenia, Spain, Sweden, Switzerland and United Kingdom.



EUROPEAN COMMITTEE FOR STANDARDIZATION  
COMITÉ EUROPÉEN DE NORMALISATION  
EUROPÄISCHES KOMITEE FÜR NORMUNG

**Management Centre: rue de Stassart, 36 B-1050 Brussels**

**Contents**

Page

Foreword.....	3
1 Scope .....	4
2 Normative references .....	4
3 Terms and definitions .....	4
4 Required characteristics .....	4
4.1 Dimensions, mass .....	4
4.2 Material, protective plating .....	6
4.3 Permissible cables.....	6
4.4 Cable stripping.....	6
4.5 Tooling.....	6
4.6 Tests.....	7
5 Designation .....	8
6 Marking .....	8
7 Technical specification .....	8

**iTeh STANDARD PREVIEW**  
**(standards.iteh.ai)**

[SIST EN 3155-044:2009](https://standards.iteh.ai/catalog/standards/sist/73316d52-3371-41f9-baab-0847f5d407e4/sist-en-3155-044-2009)

<https://standards.iteh.ai/catalog/standards/sist/73316d52-3371-41f9-baab-0847f5d407e4/sist-en-3155-044-2009>

## Foreword

This document (EN 3155-044:2007) has been prepared by the European Association of Aerospace Manufacturers - Standardization (AECMA-STAN).

After enquiries and votes carried out in accordance with the rules of this Association, this Standard has received the approval of the National Associations and the Official Services of the member countries of AECMA, prior to its presentation to CEN.

This European Standard shall be given the status of a national standard, either by publication of an identical text or by endorsement, at the latest by October 2007, and conflicting national standards shall be withdrawn at the latest by October 2007.

Attention is drawn to the possibility that some of the elements of this document may be the subject of patent rights. CEN [and/or CENELEC] shall not be held responsible for identifying any or all such patent rights.

According to the CEN/CENELEC Internal Regulations, the national standards organizations of the following countries are bound to implement this European Standard: Austria, Belgium, Bulgaria, Cyprus, Czech Republic, Denmark, Estonia, Finland, France, Germany, Greece, Hungary, Iceland, Ireland, Italy, Latvia, Lithuania, Luxembourg, Malta, Netherlands, Norway, Poland, Portugal, Romania, Slovakia, Slovenia, Spain, Sweden, Switzerland and the United Kingdom.

**ITEH STANDARD PREVIEW**  
**(standards.iteh.ai)**

[SIST EN 3155-044:2009](https://standards.iteh.ai/catalog/standards/sist/73316d52-3371-41f9-baab-0847f5d407e4/sist-en-3155-044-2009)

<https://standards.iteh.ai/catalog/standards/sist/73316d52-3371-41f9-baab-0847f5d407e4/sist-en-3155-044-2009>

**EN 3155-044:2007 (E)****1 Scope**

This standard specifies the required characteristics and tests applicable to electrical contacts, male 044, type A, double crimping, class T, used in elements of connection according to EN 3155-002.

It shall be used together with EN 3155-001.

The associated female contact is defined in EN 3155-045.

**2 Normative references**

The following referenced documents are indispensable for the application of this document. For dated references, only the edition cited applies. For undated references, the latest edition of the referenced document (including any amendments) applies.

EN 2591\*, *Aerospace series — Elements of electrical and optical connection — Test methods.*

EN 3155-001, *Aerospace series — Electrical contacts used in elements of connection — Part 001: Technical specification.* <sup>1)</sup>

EN 3155-002, *Aerospace series — Electrical contacts used in elements of connection — Part 002: List and utilization of contacts.*

EN 3155-045, *Aerospace series — Electrical contacts used in elements of connection — Part 045: Contacts, electrical, female, type A, double crimping, class T — Product standard.*

MIL-DTL-22520, *Crimping tools, wire termination, general specification for.* <sup>2)</sup>

MIL-I-81969, *Installing and removal tools, connector electrical contact, general specification for.* <sup>2)</sup>

**3 Terms and definitions**

For the purposes of this standard, the terms and definitions given in EN 3155-001 apply.

**4 Required characteristics****4.1 Dimensions, mass**

Dimensions are in millimetres.

See Figure 1 and Table 1.

---

\* All parts quoted in this standard.

1) Published as AECMA Prestandard at the date of publication of this standard.

2) Published by: Department of Defense (DOD), The Pentagon, Washington D.C. 20301, USA.

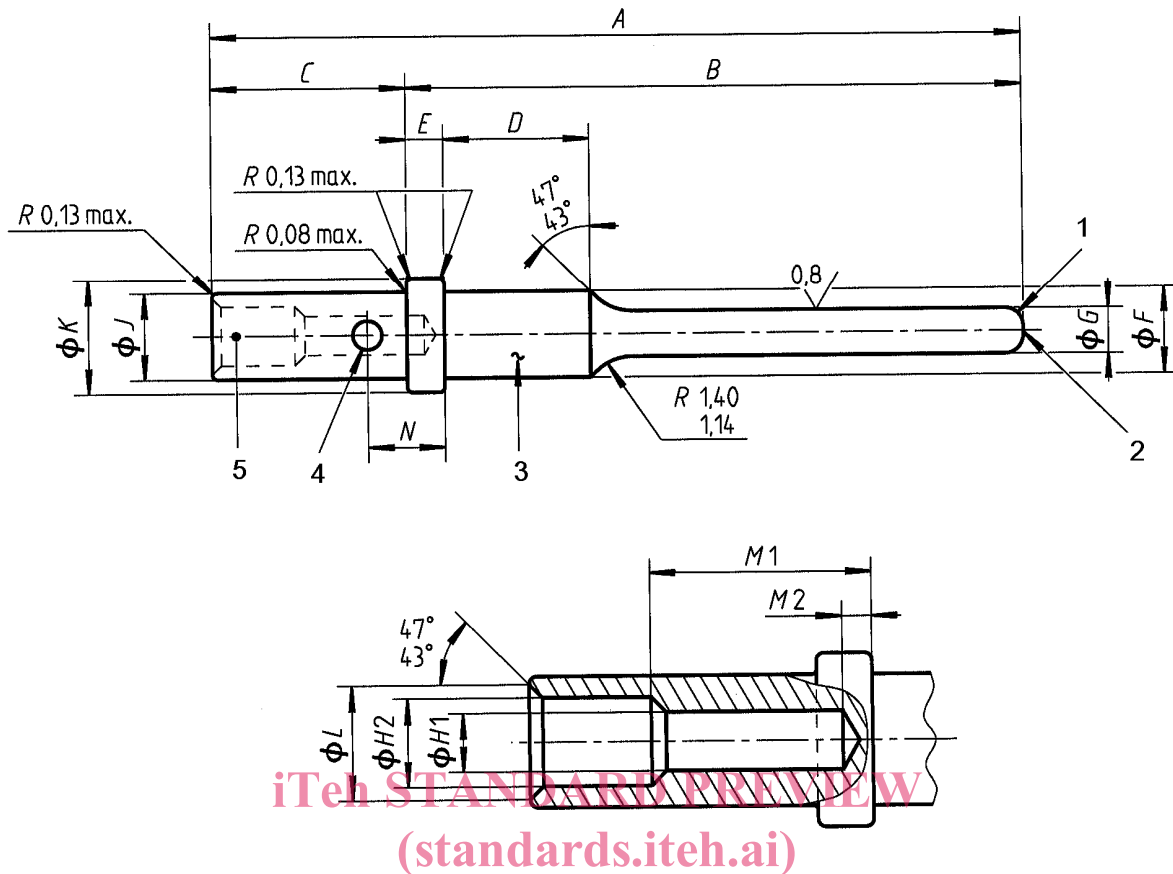
**Key**

- 1 Approximately spherical
- 2 Flat  $\varnothing S$
- 3 Manufacturer identification
- 4  $\varnothing P$  (one side only)
- 5 White dot

**Figure 1 — Detail of barrel****Table 1**

Size		<i>A</i>	<i>B</i>	<i>C</i>	<i>D</i>	<i>E</i>	<i>F</i>	<i>G</i>	<i>H</i> <sub>1</sub>	<i>H</i> <sub>2</sub>
Contact	Barrel	max.								
20	22	18,29	13,94 13,79	4,34 4,06	3,30 3,17	0,84 0,74	1,98 1,93	1,04 0,99	0,89 0,84	1,34 1,29

Size		<i>J</i>	<i>K</i>	<i>L</i>	<i>M</i> <sub>1</sub>	<i>M</i> <sub>2</sub>	<i>N</i>	<i>P</i>	<i>S</i>	Mass
Contact	Barrel									g
20	22	1,98 1,93	2,62 2,54	1,74 1,69	3,35 3,06	0,45 0,15	1,73 1,35	0,81 0,66	0,51 0,13	0,27

## EN 3155-044:2007 (E)

## 4.2 Material, protective plating

- Body material : copper alloy
- Protective plating : selective protection not permitted ; minimum gold thickness: 1,27 µm nickel undercoat

## 4.3 Permissible cables

See Table 2.

Table 2

Size		Size of conductors				Rated test current A
Contact	Barrel	AECMA Code	Section mm <sup>2</sup>	AWG <sup>a</sup>	∅ insulation max.	
20	22	004	0,4	22	1,25	5

<sup>a</sup> AWG = American Wire Gage.

## 4.4 Cable stripping

See Table 3.

iTeh STANDARD PREVIEW  
(standards.iteh.ai)

Table 3

Size		Stripped length of cable mm
Contact	Barrel	± 0,3
20	22	2,3

## 4.5 Tooling

Conform to MIL-DTL-22520 and MIL-I-81969.

See Table 4.

Table 4

Size		Cable size		Crimping tool			Insertion tool	Extraction tools	
Contact	Barrel	AECMA code	AWG <sup>a</sup>	Tool	Positioner	Selector number		Wired contact	Unwired contact
20	22	004	22	M22520/1-01	M22520/1-02 red	4	M81969/14-11	M81969/14-11	M81969/30-05

<sup>a</sup> AWG = American Wire Gage.



## 4.6 Tests

See Table 5.

Table 5

EN 2591-	Test	Not applicable	Applicable	
			According to EN 3155-001	Remarks
101	Visual examination		X	
102	Examination of dimensions and mass		X	
201	Contact resistance - low level		X	
202	Contact resistance at rated current		X	
204	Discontinuity of contacts in the microsecond range		X	
206	Measurement of insulation resistance	X		
207	Voltage proof test	X		
210	Electrical overload		X	
211	Capacitance	X		
212	Surface transfer impedance	X		
213	Shielding effectiveness from 100 MHz to 1 GHz	X		
301	Endurance at temperature		X	$T = (200 \pm 2) ^\circ\text{C}$ Duration: 1 000 h
305	Rapid change of temperature		X	$T_A = (200 \pm 2) ^\circ\text{C}$ $T_B = (-65 \pm 2) ^\circ\text{C}$
306	Mould growth	X		
307	Salt mist		X	
315	Fluid resistance	X		
402	Shock		X	
403	Sinusoidal and random vibration		X	
406	Mechanical endurance		X	
415	Test probe damage (female contact)	X		
416	Contact bending strength		X	
417	Tensile strength (crimped connection)		X	Crimping on sheath, inoperative
418	Gauge insertion/extraction forces (female contacts)	X		
502	Restricted entry	X		
503	Contact deformation after crimping		X	
508	Measurement of thickness of coating on contacts		X	
509	Adhesion of coating on contacts		X	
513	Magnetic permeability		X	$\leq 2$