



SLOVENSKI STANDARD
SIST EN 13871:2005/AC:2005

01-november-2005

Strojna predelava hrane – Stroji za razkosavanje – Varnostne in higienske zahteve

Food processing machinery - Cubes cutting machinery - Safety and hygiene requirements

Nahrungsmittelmaschinen - Würfelschneidemaschinen - Sicherheits- und Hygieneanforderungen

Machines pour les produits alimentaires - Machines a couper en cubes - Prescriptions relatives a la sécurité et a l'hygiène

SIST EN 13871:2005/AC:2005
<https://standards.iteh.ai/catalog/standards/sist/0a977046-958c-4528-8b55-6bd906d27efc/sist-en-13871-2005-ac-2005>

Ta slovenski standard je istoveten z: EN 13871:2005/AC:2005

ICS:

67.260

Tovarne in oprema za
živilsko industrijo

Plants and equipment for the
food industry

SIST EN 13871:2005/AC:2005

en

iTeh STANDARD PREVIEW
(standards.iteh.ai)

[SIST EN 13871:2005/AC:2005](https://standards.iteh.ai/catalog/standards/sist/0a977046-958c-4528-8b55-6bd906d27efc/sist-en-13871-2005-ac-2005)

<https://standards.iteh.ai/catalog/standards/sist/0a977046-958c-4528-8b55-6bd906d27efc/sist-en-13871-2005-ac-2005>

EUROPEAN STANDARD

EN 13871:2005/AC

NORME EUROPÉENNE

May 2005

EUROPÄISCHE NORM

Mai 2005

Mai 2005

ICS 67.260

English version
Version Française
Deutsche Fassung

Food processing machinery - Cubes cutting machinery - Safety and
hygiene requirements

Machines pour les produits alimentaires -
Machines à couper en cubes -
Prescriptions relatives à la sécurité et à
l'hygiène

Nahrungsmittelmaschinen -
Würfelschneidemaschinen - Sicherheits-
und Hygieneanforderungen

This corrigendum becomes effective on 25 May 2005 for incorporation in the official English version of the EN.

iTeh STANDARD PREVIEW

Ce corrigendum prendra effet le 25 mai 2005 pour incorporation dans la version anglaise officielle de la EN.

(standards.iteh.ai)

Die Berichtigung tritt am 25. Mai 2005 zur Einarbeitung in die offizielle Englische Fassung der EN in Kraft.

<https://standards.iteh.ai/catalog/standards/sist/0a977046-958c-4528-8b55-6bd906d27efc/sist-en-13871-2005-ac-2005>



EUROPEAN COMMITTEE FOR STANDARDIZATION
COMITÉ EUROPÉEN DE NORMALISATION
EUROPÄISCHES KOMITEE FÜR NORMUNG

Management Centre: rue de Stassart, 36 B-1050 Brussels

© 2005 CEN All rights of exploitation in any form and by any means reserved worldwide for CEN national Members.
Tous droits d'exploitation sous quelque forme et de quelque manière que ce soit réservés dans le monde entier aux membres nationaux du CEN.
Alle Rechte der Verwertung, gleich in welcher Form und in welchem Verfahren, sind weltweit den nationalen Mitgliedern von CEN vorbehalten.

Ref. No.: EN 13871:2005/AC:2005 E

EN 13871:2005/AC:2005 (E)

English version

Figure 2 is to be revised as follows:

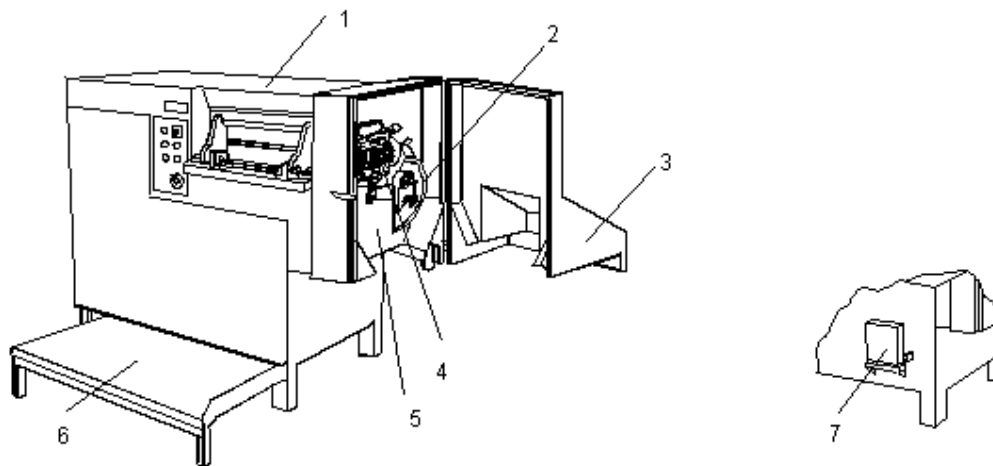

Key

- | | | | |
|---|--------------------------------------|---|------------------|
| 1 | Feed intake trough | 5 | Cutting chamber |
| 2 | Sickle blade/multi-segment blade | 6 | Step |
| 3 | Cutting chamber door/protective hood | 7 | Interlocked step |
| 4 | Lattice | | |

Figure 2 — Cubes cutting machine type with forward feed plunger, lattice and sickle blade and loading by hand

This corrigendum applies to the English version only.