



SLOVENSKI STANDARD
SIST EN 13395-1:2002
01-november-2002

Df c[nj cX]]b`g]ghYa]`nUnUy]lc`]b`dcdfUj]c`VYfcbg_]`_cbgffi _VY^!`DfYg_i gbY
a YlcXY!`8 c`c Yj Ub^Y`cVXYUj bcghj`!`%`XY. `DfYg_i g`fUn`YnUq_gclfcdb]`a Uh

Products and systems for the protection and repair of concrete structures - Test methods
- Determination of workability - Part 1: Test for flow of thixotropic mortars

Produkte und Systeme für den Schutz und die Instandsetzung von Betontragwerken -
Prüfverfahren - Bestimmung der Verarbeitbarkeit Teil 1: Prüfung des Fließverhaltens
von thixotropem Mörtel

(standards.iteh.ai)

Produits et systemes de protection et de réparation des structures en béton - Méthodes
d'essai - Détermination de l'ouvrabilité - Partie 1: Essai d'écoulement des mortiers
thixotropes

Ta slovenski standard je istoveten z: EN 13395-1:2002

ICS:

91.080.40	Betonske konstrukcije	Concrete structures
91.100.10	Cement. Mavec. Apno. Malta	Cement. Gypsum. Lime. Mortar

SIST EN 13395-1:2002 en

iTeh STANDARD PREVIEW
(standards.iteh.ai)

SIST EN 13395-1:2002

<https://standards.iteh.ai/catalog/standards/sist/5999b5ba-6a4e-4a22-99d3-8684c1181882/sist-en-13395-1-2002>

EUROPEAN STANDARD
NORME EUROPÉENNE
EUROPÄISCHE NORM

EN 13395-1

May 2002

ICS 91.080.40; 91.100.10

English version

Products and systems for the protection and repair of concrete structures - Test methods - Determination of workability - Part 1: Test for flow of thixotropic mortars

Produits et systèmes de protection et de réparation des structures en béton - Méthodes d'essai - Détermination de l'ouvrabilité - Partie 1: Essai d'écoulement des mortiers thixotropes

Produkte und Systeme für den Schutz und die Instandsetzung von Betontragwerken - Prüfverfahren - Bestimmung der Verarbeitbarkeit - Teil 1: Prüfung des Fließverhaltens von thixotropem Mörtel

This European Standard was approved by CEN on 5 January 2002.

CEN members are bound to comply with the CEN/CENELEC Internal Regulations which stipulate the conditions for giving this European Standard the status of a national standard without any alteration. Up-to-date lists and bibliographical references concerning such national standards may be obtained on application to the Management Centre or to any CEN member.

This European Standard exists in three official versions (English, French, German). A version in any other language made by translation under the responsibility of a CEN member into its own language and notified to the Management Centre has the same status as the official versions.

CEN members are the national standards bodies of Austria, Belgium, Czech Republic, Denmark, Finland, France, Germany, Greece, Iceland, Ireland, Italy, Luxembourg, Malta, Netherlands, Norway, Portugal, Spain, Sweden, Switzerland and United Kingdom.



EUROPEAN COMMITTEE FOR STANDARDIZATION
COMITÉ EUROPÉEN DE NORMALISATION
EUROPÄISCHES KOMITEE FÜR NORMUNG

Management Centre: rue de Stassart, 36 B-1050 Brussels

Contents

	page
Foreword.....	3
1 Scope	4
2 Normative references	4
3 Terms and definitions.....	4
4 Principle	4
5 Equipment.....	4
6 Preparation and storage of test samples	5
7 Procedure	5
8 Expression of results	5
9 Test report	6
Bibliography	8

iTeh STANDARD PREVIEW
(standards.iteh.ai)

[SIST EN 13395-1:2002](https://standards.iteh.ai/catalog/standards/sist/5999b5ba-6a4e-4a22-99d3-8684c1181882/sist-en-13395-1-2002)

<https://standards.iteh.ai/catalog/standards/sist/5999b5ba-6a4e-4a22-99d3-8684c1181882/sist-en-13395-1-2002>

Foreword

This document EN 13395-1:2002 has been prepared by Technical Committee CEN/TC 104 "Concrete and related products", the secretariat of which is held by DIN.

This European Standard shall be given the status of a national standard, either by publication of an identical text or by endorsement, at the latest by November 2002, and conflicting national standards shall be withdrawn at the latest by December 2002.

It has been prepared by sub-committee 8 "Products and systems for the protection and repair of concrete structures" the secretariat of which is held by AFNOR.

This European Standard is one of a series dealing with products and systems for the protection and repair of concrete structures. It describes a test method for determining the workability of thixotropic repair mortars.

It is one of inter-related parts dealing with the workability of repair grouts, mortars and concretes. The other parts are:

EN 13395-2, *Products and systems for the protection and repair of concrete structures - Test methods - Determination of workability - Part 2: Test for flow of grout or mortar.*

EN 13395-3, *Products and systems for the protection and repair of concrete structures - Test methods - Determination of workability - Part 3: Test for flow of repair concrete.*

EN 13395-4, *Products and systems for the protection and repair of concrete structures - Test methods - Determination of workability - Part 4: Application of repair mortar overhead.*

According to the CEN/CENELEC Internal Regulations, the national standards organizations of the following countries are bound to implement this European Standard: Austria, Belgium, Czech Republic, Denmark, Finland, France, Germany, Greece, Iceland, Ireland, Italy, Luxembourg, Malta, Netherlands, Norway, Portugal, Spain, Sweden, Switzerland and the United Kingdom.

EN 13395-1:2002 (E)**1 Scope**

This European Standard specifies a method for determining the workability (or consistence) of trowel-grade hydraulic cement mortars CC, polymer modified hydraulic cement mortars PCC and polymer bound mortars PC for the protection and repair of concrete, as defined in EN 1504-1.

2 Normative references

This European Standard incorporates by dated or undated reference, provisions from other publications. These normative references are cited at the appropriate places in the text, and the publications are listed hereafter. For dated references, subsequent amendments to or revisions of any of these publications apply to this European Standard only when incorporated in it by amendment or revision. For undated references the latest edition of the publication referred to applies (including amendments).

EN 196-1, *Methods of testing cement - Part 1: Determination of strength*.

EN 1015-3:1998, *Methods of test for mortar for masonry – Part 3: Determination of consistence of fresh mortar (by flow table)*.

EN 1504-1, *Products and systems for the protection and repair of concrete structures – Definitions, requirements, quality control and evaluation of conformity - Part 1: Definitions*.

prEN 1504-3¹, *Products and systems for the protection and repair of concrete structures - Part 3: Structural and non-structural repair*.

ITC STANDARD PREVIEW
(standards.iteh.ai)

3 Terms and definitions

SIST EN 13395-1:2002

<https://standards.iteh.ai/catalog/standards/sist/5999b5ba-6a4e-4a22-99d3-8664c1161882/sist-en-13395-1-2002>

For the purposes of this European Standard, the following terms and definitions contained in EN 1504-1 and prEN 1504-3¹ apply.

4 Principle

The workability of the thixotropic mortar is measured by the spread of a defined test sample when placed on a flow table, with the spread being achieved by a set number of jolts, whereby the platen of the table is raised slightly and then dropped back to the resting position. The method is based on EN 1015-3.

NOTE Trowel-grade repair products are normally mortars, applied by hand to horizontal, vertical or overhead surfaces using appropriate compaction and levelling tools.

5 Equipment

5.1 Mortar mixer, in accordance with EN 196-1, or **concrete mixer**, (forced action pan mixer).

5.2 Tamper consisting of a round, non-absorptive rod, (40 ± 1) mm in diameter and with a length of (200 ± 10) mm. The tamping face shall be a flat, square end. The mass of the tamper shall be $(0,250 \pm 0,015)$ kg.

5.3 Flow table and truncated conical mould as described in annex A of EN 1015-3:1998 and shown in Figure 1.

5.4 Calipers capable of measuring diameters up to 300 mm with an accuracy of 1 mm.

¹ Under preparation.

5.5 Standard laboratory climate of (21 ± 2) °C and (60 ± 10) % RH.

5.6 A stop watch or stop cock accurate to 1 s.

6 Preparation and storage of test samples

All materials shall be conditioned in the standard laboratory climate (5.5) for a period of not less than 24-h prior to mixing.

Unless otherwise instructed by the manufacturer, use the following mixing technique for preparing the specimens.

For PCC and CC mortars, use the mortar mixer (5.1) set to a low speed, pouring the gauging liquid to the bowl and adding the dry ingredients, mixing for a total period of two minutes after addition of all ingredients.

Where manufacturer's instructions preclude use of part bags of material, a concrete mixer (5.1) or other method recommended by the manufacturer shall be used.

NOTE It has been found that certain types of repair mortar can foam excessively under the action of the mortar mixer specified in EN 196-1.

An alternative is to use a concrete mixer (5.1).

The air content, strength and density of the HC and PCC mixes should normally be determined to characterise the mortar under test.

iTeh STANDARD PREVIEW
(standards.iteh.ai)

7 Procedure

The flow value shall be determined in the standard laboratory climate. The sample shall be tested after (10 ± 5) min, (30 ± 5) min or at other periods agreed with the manufacturer. Prior to testing, the mortar shall be remixed for a period of (20 ± 2) s. Two samples shall be tested at each time interval.

NOTE In addition, the flow value for the mortar can be determined at other temperatures for special applications.

Before the start of each test, the platen of the flow table and the inner surface and edges of the conical mould shall be wiped clean with a damp cloth. If the table has not been used within the last 24 h, operate for ten revolutions of the shaft to check for function.

To measure the flow value, the conical mould shall be placed centrally on the platen of the flow table and the mortar introduced in two layers, each being compacted by short strokes of the tamper to ensure uniform filling of the mould is achieved. During filling, the conical mould shall be held firmly down on the platen to prevent loss of material from under the mould.

Skim off the excess mortar and wipe clean the free area of the platen, being especially careful to remove any water from around the bottom edge of the conical mould. After 30 s, slowly raise the mould vertically and, by turning the shaft, jolt the platen 15 times at a frequency, as near as possible, to one of one drop per second.

8 Expression of results

The diameter of the mortar on the platen, which will have spread as a result of the energy from the drop action, shall be measured in two directions at right angles to one another using the calipers. Record the result to the nearest 1 mm and calculate the mean value of the two tests at each time interval. The flow value is equivalent to the mean result. If the two values for a batch of mortar differ by more than 10 % from their mean Flow Value, two additional samples shall be taken and tested.

EN 13395-1:2002 (E)**9 Test report**

The test report shall include the following information:

- a) a reference to the test method standard;
- b) name and address of the test laboratory;
- c) identification number and date of the test;
- d) name and address of the manufacturer or supplier of the product;
- e) name and identification marks or batch number of the product;
- f) date of supply of the product;
- g) date of preparation of the test specimens and any deviation from the prescribed method of preparation;
- h) conditions of storage of prepared specimens prior to test;
- i) date of test and details of the test equipment used, including the make, type and capacity and the calibration details or the identification number of the apparatus;
- j) the test results, including the individual values and mean Flow Value;
- k) precision data;
- l) date of test report and signature.

iTeh STANDARD PREVIEW
(standards.iteh.ai)
[SIST EN 13395-1:2002
https://standards.iteh.ai/catalog/standards/sist/5999b5ba-6a4e-4a22-99d3-8684c1181882/sist-en-13395-1-2002](https://standards.iteh.ai/catalog/standards/sist/5999b5ba-6a4e-4a22-99d3-8684c1181882/sist-en-13395-1-2002)

Dimensions in millimetres

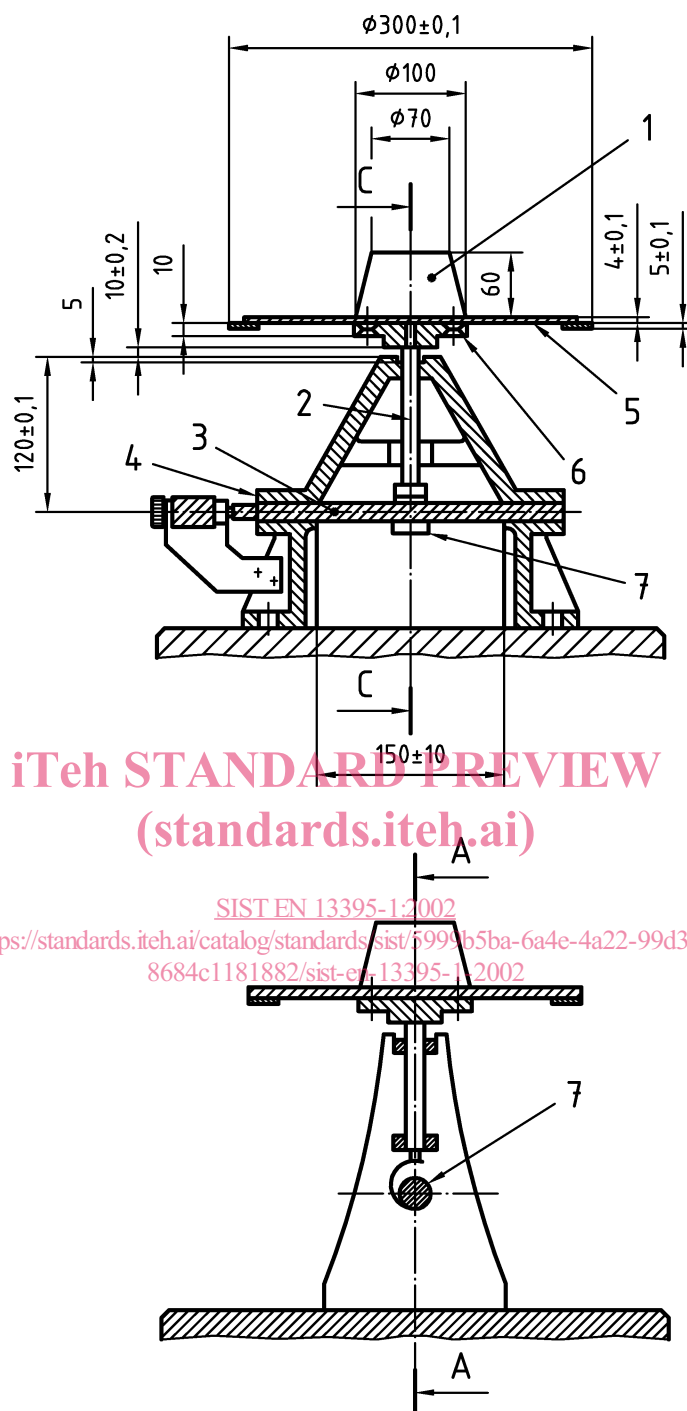
**Key**

- | | | | |
|---|-------------------------|---|------------------|
| 1 | Truncated conical mould | 5 | Stand |
| 2 | Disc | 6 | Horizontal shaft |
| 3 | Rigid table plate | 7 | Lifting spindle |
| 4 | Lifting cam | | |

Figure 1 — Vibrating table