



# SLOVENSKI STANDARD

## SIST EN 4172:2008

01-junij-2008

---

**Aeronavtika - Zapirni vijaki, dvignjena glava, strižni tip, ozka toleranca, iz titanove zlitine TI-P64001, anodizirani, metrska serija - Klasifikacija: 1 100 MPa (pri temperaturi okolice) / 315 °C**

Aerospace series - Lockbolts, protruding head, sheartype, close tolerance, in titanium alloy TI-P64001, anodized, metric series - Classification: 1 100 MPa (at ambient temperature) / 315 °C

Luft- und Raumfahrt - Passniete, mit Universalkopf, Schertyp, aus Titanlegierung TI-P64001, anodisiert, metrische Reihe - Klasse 1.100 MPa (bei Raumtemperatur) / 315 °C

Série aérospatiale - Rivets à bague sertie, à tête cylindrique, à cisaillement, à tolérance serrée, en alliage de titane TI-P64001, anodisés, série métrique - Classification : 1 100 MPa (à température ambiante) / 315 °C

**Ta slovenski standard je istoveten z: EN 4172:2006**

---

**ICS:**

49.030.20 Sorniki, vijaki, stebelni vijaki Bolts, screws, studs

**SIST EN 4172:2008**

**en,de**

**iTeh STANDARD PREVIEW**  
**(standards.iteh.ai)**

SIST EN 4172:2008

<https://standards.iteh.ai/catalog/standards/sist/862ea72e-80b7-45a6-87bd-bf94045346bf/sist-en-4172-2008>

EUROPEAN STANDARD

EN 4172

NORME EUROPÉENNE

EUROPÄISCHE NORM

April 2006

ICS 49.030.60

English Version

**Aerospace series - Lockbolts, protruding head, sheartype, close tolerance, in titanium alloy TI-P64001, anodized, metric series - Classification: 1 100 MPa (at ambient temperature) / 315 °C**

Série aérospatiale - Rivets à bague sertie, à tête cylindrique, à cisaillement, à tolérance serrée, en alliage de titane TI-P64001, anodisés, série métrique - Classification : 1 100 MPa (à température ambiante) / 315 °C

Luft- und Raumfahrt - Paßniete, mit Universalkopf, Schertyp, aus Titanlegierung TI-P64001, anodisiert, metrische Reihe - Klasse: 1 100 MPa (bei Raumtemperatur) / 315 °C

This European Standard was approved by CEN on 13 January 2006.

CEN members are bound to comply with the CEN/CENELEC Internal Regulations which stipulate the conditions for giving this European Standard the status of a national standard without any alteration. Up-to-date lists and bibliographical references concerning such national standards may be obtained on application to the Central Secretariat or to any CEN member.

This European Standard exists in three official versions (English, French, German). A version in any other language made by translation under the responsibility of a CEN member into its own language and notified to the Central Secretariat has the same status as the official versions.

CEN members are the national standards bodies of Austria, Belgium, Cyprus, Czech Republic, Denmark, Estonia, Finland, France, Germany, Greece, Hungary, Iceland, Ireland, Italy, Latvia, Lithuania, Luxembourg, Malta, Netherlands, Norway, Poland, Portugal, Romania, Slovakia, Slovenia, Spain, Sweden, Switzerland and United Kingdom.



EUROPEAN COMMITTEE FOR STANDARDIZATION  
COMITÉ EUROPÉEN DE NORMALISATION  
EUROPÄISCHES KOMITEE FÜR NORMUNG

Management Centre: rue de Stassart, 36 B-1050 Brussels

<b>Contents</b>		<b>Page</b>
<b>Foreword</b> .....		<b>3</b>
<b>1</b>	<b>Scope</b> .....	<b>4</b>
<b>2</b>	<b>Normative references</b> .....	<b>4</b>
<b>3</b>	<b>Required characteristics</b> .....	<b>4</b>
<b>4</b>	<b>Description</b> .....	<b>7</b>
<b>5</b>	<b>Marking</b> .....	<b>7</b>
<b>6</b>	<b>Technical specification</b> .....	<b>7</b>

**iTeh STANDARD PREVIEW**  
**(standards.iteh.ai)**

SIST EN 4172:2008

<https://standards.iteh.ai/catalog/standards/sist/862ea72e-80b7-45a6-87bd-bf94045346bf/sist-en-4172-2008>

## Foreword

This European Standard (EN 4172:2006) has been prepared by the European Association of Aerospace Manufacturers - Standardization (AECMA-STAN).

After enquiries and votes carried out in accordance with the rules of this Association, this Standard has received the approval of the National Associations and the Official Services of the member countries of AECMA, prior to its presentation to CEN.

This European Standard shall be given the status of a national standard, either by publication of an identical text or by endorsement, at the latest by October 2006, and conflicting national standards shall be withdrawn at the latest by October 2006.

Attention is drawn to the possibility that some of the elements of this document may be the subject of patent rights. CEN [and/or CENELEC] shall not be held responsible for identifying any or all such patent rights.

According to the CEN/CENELEC Internal Regulations, the national standards organizations of the following countries are bound to implement this European Standard: Austria, Belgium, Cyprus, Czech Republic, Denmark, Estonia, Finland, France, Germany, Greece, Hungary, Iceland, Ireland, Italy, Latvia, Lithuania, Luxembourg, Malta, Netherlands, Norway, Poland, Portugal, Romania, Slovakia, Slovenia, Spain, Sweden, Switzerland and the United Kingdom.

**ITIH STANDARD PREVIEW**  
**(standards.iteh.ai)**

SIST EN 4172:2008

<https://standards.iteh.ai/catalog/standards/sist/862ea72e-80b7-45a6-87bd-bf94045346bf/sist-en-4172-2008>

**EN 4172:2006 (E)****1 Scope**

This standard specifies the characteristics of lockbolts with protruding head, sheartype, close tolerance, in titanium alloy TI-P64001, anodized, metric series, for use in aerospace applications.

Classification : 1 100 MPa <sup>1)</sup> / 315 °C <sup>2)</sup>

In both versions, i.e. with and without pintail these lockbolts fulfill the same function when installed and are statically / dynamically equivalent.

They are intended to be used with collars to EN 4174 or EN 4175.

**2 Normative references**

The following referenced documents are indispensable for the application of this document. For dated references, only the edition cited applies. For undated references, the latest edition of the referenced document (including any amendments) applies.

EN 2424, *Aerospace series – Marking of aerospace products.*

EN 2808, *Aerospace series – Anodizing of titanium and titanium alloys.*

EN 4174, *Aerospace series – Collars, swage locking, sheartype, in aluminium alloy 2024, anodized or chromated, metric series.*

EN 4175, *Aerospace series – Collars, flanged swage locking, sheartype, in titanium TI-P99002, metric series.*

EN 4176, *Aerospace series – Lockbolts, 100° countersunk normal head or protruding head, tension- / shear-type, close tolerance, in titanium alloy TI-P64001, anodized or with aluminium pigmented coating – Collars in titanium TI-P99002 or in aluminium alloy 2024 – Metric series – Technical specification.*

MIL-L-87132B, *Lubricant, Cetyl Alcohol, 1-Hexadecanol, Application to Fasteners.* <sup>3)</sup>

TR 3775, *Aerospace series – Bolts and pins – Materials.* <sup>4)</sup>

**3 Required characteristics****3.1 Configuration - Dimensions - Masses**

See Figure 1 and Tables 1 and 2.

Dimensions and tolerances are expressed in millimetres and apply after surface treatment.

---

1) Minimum tensile strength of the material at ambient temperature

2) Maximum temperature that the lockbolt can withstand without continuous change in its original characteristics, after return to ambient temperature. The maximum temperature is determined by the material.

3) Published by: Department of Defense (DoD), the Pentagon, Washington, D.C.20301, USA.

4) Published as AECMA Technical Report at the date of publication of this standard.

### 3.2 Materials

TR 3775 (titanium alloy, strength class 1 100 MPa)

### 3.3 Surface treatments

EN 2808

Lubrication with cetylic alcohol (chlorine free) according to MIL-L-87132

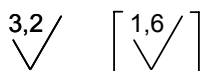

Values in micrometres apply prior to surface treatment.

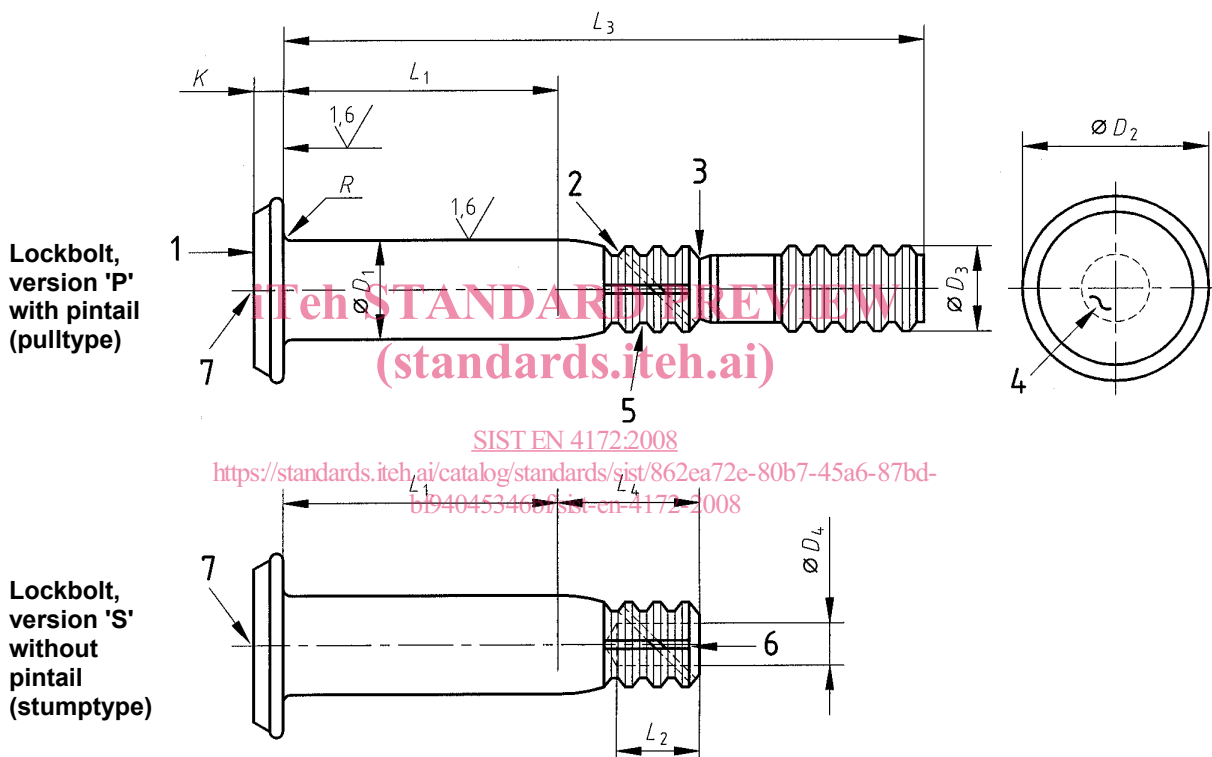

#### Key

- 1 Location of manufacture's symbol
- 2 Sealant escape groove option: code G
- 3 Predetermined breaking point
- 4 Marking
- 5 Groove section at manufacturer's option
- 6 Lightening hole
- 7 Drill start

Figure 1

Table 1

Diameter code	$D_1$	$D_2$	$D_3$	$D_4$	$L_2$	$L_4$	$K$		$R$	
	f7	0 - 0,51	max.	max.	max.		max.	min.	max.	min.
040	4	8,74	3,88	1,65	2,95	4,6	1,5	1,25	0,65	0,4
050	5	9,83	4,89	2,18	3	5	1,7	1,45		
060	6	12,37	5,89	2,77	4,12	6,15	1,93	1,68		
080	8	15,47	7,88	3,58	5,49	8,4	2,18	1,8	0,75	0,5
100	10	18,42	9,88	4,34	6,17	10,6	2,56	2,18		

Table 2

Diameter code			040		050		060		080		100		
code	Length $L_1^a$ $\pm 0,25$	Grip length		$L_3$ +2 0	Mass <sup>b</sup>	$L_3$ +2 0	Mass <sup>b</sup>	$L_3$ +2 0	Mass <sup>b</sup>	$L_3$ +2 0	Mass <sup>b</sup>	$L_3$ +2 0	Mass <sup>b</sup>
		over	to										
040	4	2	4	20,9	0,67	23,3	1,08	25,6	1,94	29,2	3,91	33,4	6,49
060	6	4	6	22,9	0,78	25,3	1,25	27,6	2,19	31,2	4,35	35,4	7,19
080	8	6	8	24,9	0,89	27,3	1,42	29,6	2,44	33,2	4,79	37,4	7,89
100	10	8	10	26,9	1,00	29,3	1,59	31,6	2,69	35,2	5,23	39,4	8,59
120	12	10	12	28,9	1,11	31,3	1,76	33,6	2,94	37,2	5,67	41,4	9,29
140	14	12	14	30,9	1,22	33,3	1,93	35,6	3,19	39,2	6,11	43,4	9,99
160	16	14	16	32,9	1,33	35,3	2,10	37,6	3,44	41,2	6,55	45,4	10,69
180	18	16	18	34,9	1,44	37,3	2,27	39,6	3,69	43,2	6,99	47,4	11,39
200	20	18	20	36,9	1,55	39,3	2,44	41,6	3,94	45,2	7,43	49,4	12,09
220	22	20	22	38,9	1,66	41,3	2,61	43,6	4,19	47,2	7,87	51,4	12,79
240	24	22	24	40,9	1,77	43,3	2,78	45,6	4,44	49,2	8,31	53,4	13,49
260	26	24	26	42,9	1,88	45,3	2,95	47,6	4,69	51,2	8,75	55,4	14,19
280	28	26	28	44,9	1,99	47,3	3,12	49,6	4,94	53,2	9,19	57,4	14,89
300	30	28	30	46,9	2,10	49,3	3,29	51,6	5,19	55,2	9,63	59,4	15,59
320	32	30	32	48,9	2,21	51,3	3,46	53,6	5,44	57,2	10,07	61,4	16,29
340	34	32	34	50,9	2,32	53,3	3,63	55,6	5,69	59,2	10,51	63,4	16,99
360	36	34	36	52,9	2,43	55,3	3,80	57,6	5,94	61,2	10,95	65,4	17,69
380	38	36	38	54,9	2,54	57,3	3,97	59,6	6,19	63,2	11,39	67,4	18,39
400	40	38	40	56,9	2,65	59,3	4,14	61,6	6,44	65,2	11,83	69,4	19,09
420	42	40	42	58,9	2,76	61,3	4,31	63,6	6,69	67,2	12,27	71,4	19,79
440	44	42	44	60,9	2,87	63,3	4,48	65,6	6,94	69,2	12,71	73,4	20,49
460	46	44	46	62,9	2,98	65,3	4,65	67,6	7,19	71,2	13,15	75,4	21,19
480	48	46	48	64,9	3,09	67,3	4,82	69,6	7,44	73,2	13,59	77,4	21,89
500	50	48	50	66,9	3,20	69,3	4,99	71,6	7,69	75,2	14,03	79,4	22,59

<sup>a</sup> Measured from the bearing surface under the head to the end of full cylindrical portion of shank.

<sup>b</sup> Approximate values (kg/1 000 installed pieces without collar), calculated on the basis of 4,45 kg/dm<sup>3</sup>, for information purposes only. Mass reduction for version "S" = 5 %. Average is depending of grip length.