



SLOVENSKI STANDARD

SIST EN 4303:2006

01-september-2006

Aeronavtika – Puše, cevaste, za vijake z ugrezno glavo za natezno obremenitev, iz korozijsko odpornega jekla, pasivirane (debelina stene 0,25 mm)

Aerospace series - Sleeves, tubular, for tension screws with flush head, in corrosion resisting steel, passivated, (0,25 mm wall thickness)

Luft- und Raumfahrt - Hülsen für Senkschrauben mit Zugbeanspruchung, aus korrosionsbeständigem Stahl, passiviert, (Wanddicke 0,25 mm)

Série aérospatiale - Douilles tubulaires, pour vis de traction à tête fraisée, en acier résistant à la corrosion, passivées, (épaisseur de paroi 0,25 mm)

iTeh STANDARD PREVIEW

<https://standards.iteh.ai/catalog/standards/sist/5d922504-7f5e-4efd-bde1-6ad2293b1d6/sist-en-4303-2006>

Ta slovenski standard je istoveten z: EN 4303:2005

ICS:

49.030.99

SIST EN 4303:2006

en

iTeh STANDARD PREVIEW
(standards.iteh.ai)

SIST EN 4303:2006

<https://standards.iteh.ai/catalog/standards/sist/5d922504-7f5e-4efd-bde1-daa22093b1d6/sist-en-4303-2006>

ICS 49.030.99

English Version

Aerospace series - Sleeves, tubular, for tension screws with flush head, in corrosion resisting steel, passivated, (0,25 mm wall thickness)

Série aérospatiale - Douilles tubulaires, pour vis de traction à tête fraisée, en acier résistant à la corrosion, passivées, (épaisseur de paroi 0,25 mm)

Luft- und Raumfahrt - Hülsen für Senkschrauben mit Zugbeanspruchung, aus korrosionsbetändigem Stahl, passiviert, (Wanddicke 0,25 mm)

This European Standard was approved by CEN on 26 October 2005.

CEN members are bound to comply with the CEN/CENELEC Internal Regulations which stipulate the conditions for giving this European Standard the status of a national standard without any alteration. Up-to-date lists and bibliographical references concerning such national standards may be obtained on application to the Central Secretariat or to any CEN member.

This European Standard exists in three official versions (English, French, German). A version in any other language made by translation under the responsibility of a CEN member into its own language and notified to the Central Secretariat has the same status as the official versions.

CEN members are the national standards bodies of Austria, Belgium, Cyprus, Czech Republic, Denmark, Estonia, Finland, France, Germany, Greece, Hungary, Iceland, Ireland, Italy, Latvia, Lithuania, Luxembourg, Malta, Netherlands, Norway, Poland, Portugal, Slovakia, Slovenia, Spain, Sweden, Switzerland and United Kingdom.

<https://standards.iteh.ai/catalog/standards/sist/5d922504-7f5e-4efd-bde1-daa22093b1d6/sist-en-4303-2006>



EUROPEAN COMMITTEE FOR STANDARDIZATION
COMITÉ EUROPÉEN DE NORMALISATION
EUROPÄISCHES KOMITEE FÜR NORMUNG

Management Centre: rue de Stassart, 36 B-1050 Brussels

Contents		Page
Foreword		3
1	Scope	4
2	Normative references	4
3	Terms and definitions	4
4	Required characteristics	4
5	Designation	7
6	Marking	7
7	Technical specification.....	7

iTeh STANDARD PREVIEW
(standards.iteh.ai)

SIST EN 4303:2006

<https://standards.iteh.ai/catalog/standards/sist/5d922504-7f5e-4efd-bde1-daa22093b1d6/sist-en-4303-2006>

Foreword

This European Standard (EN 4303:2005) has been prepared by the European Association of Aerospace Manufacturers - Standardization (AECMA-STAN).

After enquiries and votes carried out in accordance with the rules of this Association, this Standard has received the approval of the National Associations and the Official Services of the member countries of AECMA, prior to its presentation to CEN.

This European Standard shall be given the status of a national standard, either by publication of an identical text or by endorsement, at the latest by June 2006, and conflicting national standards shall be withdrawn at the latest by June 2006.

Attention is drawn to the possibility that some of the elements of this document may be the subject of patent rights. CEN [and/or CENELEC] shall not be held responsible for identifying any or all such patent rights.

According to the CEN/CENELEC Internal Regulations, the national standards organizations of the following countries are bound to implement this European Standard: Austria, Belgium, Cyprus, Czech Republic, Denmark, Estonia, Finland, France, Germany, Greece, Hungary, Iceland, Ireland, Italy, Latvia, Lithuania, Luxembourg, Malta, Netherlands, Norway, Poland, Portugal, Slovakia, Slovenia, Spain, Sweden, Switzerland and the United Kingdom.

ITeH STANDARD PREVIEW
(standards.iteh.ai)

SIST EN 4303:2006

<https://standards.iteh.ai/catalog/standards/sist/5d922504-7f5e-4efd-bde1-daa22093b1d6/sist-en-4303-2006>

1 Scope

This standard specifies the characteristics and technical requirements of tubular sleeves for tension screws with flush head, which may be plain or provided with a series of annular grooves, in corrosion resisting steel, passivated, with a 0,25 mm wall thickness, for maximum operating temperature 650 °C, for aerospace applications.

2 Normative references

The following referenced documents are indispensable for the application of this document. For dated references, only the edition cited applies. For undated references, the latest edition of the referenced document (including any amendments) applies.

ISO 2859-1, *Sampling procedures for inspection by attributes – Part 1: Sampling schemes indexed by acceptance quality limit (AQL) for lot-by-lot inspection.*

EN 2175, *Aerospace series – Heat resisting alloy FE-PA2602 (X4NiCrTiMoV26-15) – Solution treated and precipitation treated – Sheet, strip and plate – 0,5 mm ≤ a ≤ 10 mm – R_m ≥ 850 MPa.*¹⁾

EN 2424, *Aerospace series – Marking of aerospace products.*

EN 2516, *Aerospace series – Passivation of corrosion resisting steels and decontamination of nickel base alloys.*

iTeh STANDARD PREVIEW
(standards.iteh.ai)

3 Terms and definitions

For the purposes of this standard, the following terms and definitions apply.
<https://standards.iteh.ai/catalog/standards/sist/5d922564-7f5e-4efd-bde1-daa22093b1d6/sist-en-4303-2006>

3.1

crack

rupture in the material which may extend in any direction and which may be intercrystalline or transcrystalline in character

3.2

seam

open surface defect which is the result of the extrusion of the material

3.3

lap

surface defect caused by folding over metal fins or sharp corners and then rolling or forging them into the surface

4 Required characteristics

4.1 Configuration - Dimensions - Masses

See Figure 1 and Tables 1 and 2.

Dimensions and tolerances are expressed in millimetres and apply after surface treatment.

1) Published as AECMA Prestandard at the date of publication of this standard.

4.2 Material

EN 2175, received in the annealed condition and cold work during manufacture

4.3 Surface treatment

EN 2516



Values in micrometres apply prior to surface treatment.

Remove sharp edges 0,1 to 0,2.

Plain form
(code "P")

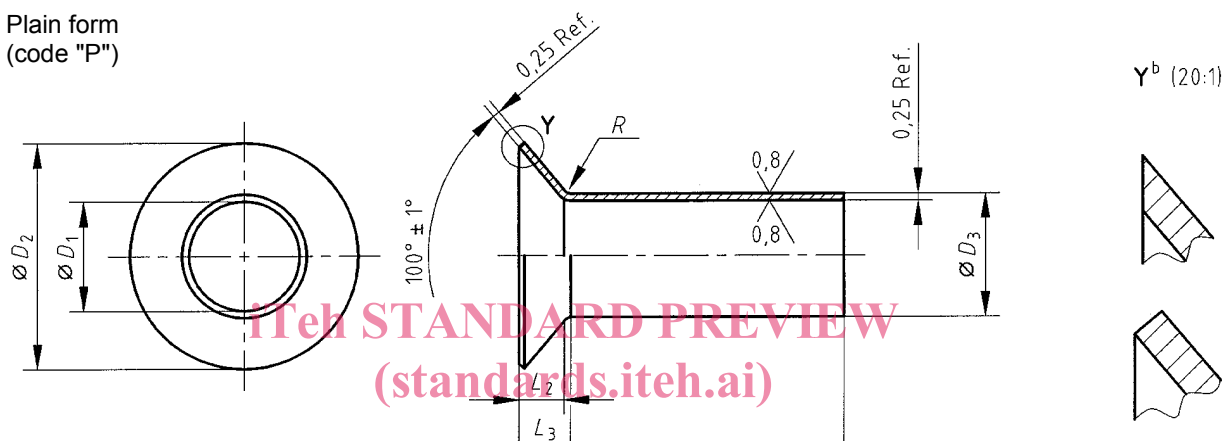

Grooved form
(code "G")^a

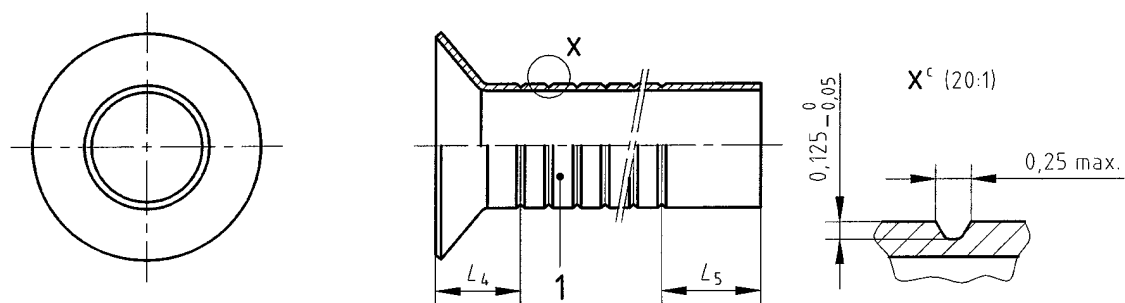

Key

- 1 Z: Number of grooves. The Pitch of groove = 2
- ^a Unspecified dimensions: as plain form
- ^b At manufacturer's option
- ^c Form of groove at manufacturer's option

Figure 1

Table 1

Diameter code	D_1		D_2	D_3		L_2	L_3	L_4	L_5	R + 0,25 - 0,05	Z
	max.	min.	$\pm 0,3$	max.	min.			$\pm 0,5$	$\pm 0,5$		
050	4,999	4,96	10	5,499	5,474	2,1	2,22	4	5,5	0,5	7
060	5,999	5,96	12	6,499	7,474	2,6	2,72		7		
080	7,994	7,955	16	8,494	8,47	3,4	3,52	6	10		6
100	9,994	9,955	20	10,494	10,47	4,2	4,32		5		
120	11,994	11,995	24	12,494	12,47	5	5,12	–	–		–

Table 2

Diameter code			050	060	080	100	120
Form code ^a	Length		Mass ^b				
	code	$L_1 + 0,5$ 0					
P	030	3	0,218	–	–	–	–
	045	4,5	0,267	0,293	–	–	–
	060	6	0,315	0,364	0,520	–	–
	075	7,5	0,364	0,435	0,597	0,812	–
	090	9	0,412	0,505	0,676	0,906	–
	105	10,5	0,461	0,576	0,749	1,001	1,196
	120	12	0,509	0,647	0,825	1,096	1,309
	135	13,5	0,558	0,718	0,902	1,190	1,422
	150	15	0,606	0,789	0,981	1,285	1,536
	165	16,5	0,655	0,859	1,054	1,380	1,649
	180	18	0,703	0,930	1,130	1,474	1,762
	195	19,5	0,752	1,001	1,206	1,569	1,875
	210	21	0,800	1,072	1,287	1,664	1,989
	225	22,5	0,849	1,143	1,359	1,758	2,102
	240	24	0,897	1,213	1,435	1,853	2,215
250	25	0,930	1,260	1,485	1,916	2,290	
G	250	25	0,930	1,260	1,485	1,916	2,290

^a See Figure 1.

^b Approximate values (kg/1 000 pieces), calculated on the basis of 7,85 kg/dm³, given for information purposes only