



SLOVENSKI STANDARD
SIST EN 13894-1:2004
01-april-2004

Določila za izdelavo in uporabo izdelkov za zaščito in popravilo betonskih konstrukcij - Metode preskušanja - Določitev utrujenosti pod dinamično obremenitvijo - Del 1: Med obdelavo

Products and systems for the protection and repair of concrete structures - Test methods - Determination of fatigue under dynamic loading - Part 1: During cure

Produkte und Systeme für den Schutz und die Instandsetzung von Betontragwerken - Prüfverfahren - Bestimmung der Dauerschwingfestigkeit unter dynamischer Belastung - Teil 1: Während des Aushärtens

(standards.iteh.ai)

Produits et systemes de protection et de réparation des structures en béton - Méthodes d'essai - Détermination de la fatigue sous charge dynamique - Partie 1: Pendant le durcissement

Ta slovenski standard je istoveten z: EN 13894-1:2003

ICS:

91.080.40 Betonske konstrukcije Concrete structures

SIST EN 13894-1:2004 en

iTeh STANDARD PREVIEW
(standards.iteh.ai)

SIST EN 13894-1:2004

<https://standards.iteh.ai/catalog/standards/sist/1b3e9b9c-793e-42e7-9aa4-f9c5f9a8d77/sist-en-13894-1-2004>

EUROPEAN STANDARD
NORME EUROPÉENNE
EUROPÄISCHE NORM

EN 13894-1

October 2003

ICS 91.080.40

English version

Products and systems for the protection and repair of concrete structures - Test methods - Determination of fatigue under dynamic loading - Part 1: During cure

Produits et systèmes de protection et de réparation des structures en béton - Méthodes d'essai - Détermination de la fatigue sous charge dynamique - Partie 1: Pendant le durcissement

Produkte und Systeme für den Schutz und die Instandsetzung von Betontragwerken - Prüfverfahren - Bestimmung der Dauerschwingfestigkeit unter dynamischer Belastung - Teil 1: Während des Aushärtens

This European Standard was approved by CEN on 10 July 2003.

CEN members are bound to comply with the CEN/CENELEC Internal Regulations which stipulate the conditions for giving this European Standard the status of a national standard without any alteration. Up-to-date lists and bibliographical references concerning such national standards may be obtained on application to the Management Centre or to any CEN member.

This European Standard exists in three official versions (English, French, German). A version in any other language made by translation under the responsibility of a CEN member into its own language and notified to the Management Centre has the same status as the official versions.

CEN members are the national standards bodies of Austria, Belgium, Czech Republic, Denmark, Finland, France, Germany, Greece, Hungary, Iceland, Ireland, Italy, Luxembourg, Malta, Netherlands, Norway, Portugal, Slovakia, Spain, Sweden, Switzerland and United Kingdom.



EUROPEAN COMMITTEE FOR STANDARDIZATION
COMITÉ EUROPÉEN DE NORMALISATION
EUROPÄISCHES KOMITEE FÜR NORMUNG

Management Centre: rue de Stassart, 36 B-1050 Brussels

Contents

page

Foreword.....	3
1	4
1 Scope	4
2 Normative references	4
3 Principle	4
4 Equipment	4
5 Procedure	4
5.1 Preparation of test pieces	4
5.2 Number of test specimens	4
5.3 Testing	5
5.4 Failure mode	5
5.5 Failure strength ratio	5
6 Test report	6

iTeh STANDARD PREVIEW
(standards.iteh.ai)

[SIST EN 13894-1:2004](https://standards.iteh.ai/catalog/standards/sist/1b3e9b9c-793e-42e7-9aa4-f9c5f9a8d77/sist-en-13894-1-2004)

<https://standards.iteh.ai/catalog/standards/sist/1b3e9b9c-793e-42e7-9aa4-f9c5f9a8d77/sist-en-13894-1-2004>

Foreword

This document (EN 13894-1:2003) has been prepared by Technical Committee CEN/TC 104 "Concrete and related products", the secretariat of which is held by DIN.

It has been prepared by Sub-Committee 8 "Products and systems for the protection and repair of concrete structures" (Secretariat, AFNOR).

This European Standard shall be given the status of a national standard, either by publication of an identical text or by endorsement, at the latest by May 2004, and conflicting national standards shall be withdrawn at the latest by May 2004.

According to the CEN/CENELEC Internal Regulations, the national standards organizations of the following countries are bound to implement this European Standard: Austria, Belgium, Czech Republic, Denmark, Finland, France, Germany, Greece, Hungary, Iceland, Ireland, Italy, Luxembourg, Malta, Netherlands, Norway, Portugal, Slovakia, Spain, Sweden, Switzerland and the United Kingdom.

iTeh STANDARD PREVIEW (standards.iteh.ai)

SIST EN 13894-1:2004

<https://standards.iteh.ai/catalog/standards/sist/1b3e9b9c-793e-42e7-9aa4-f9c5f9a8d77/sist-en-13894-1-2004>

EN 13894-1:2003 (E)**1 Scope**

This Part of this European Standard specifies a laboratory method of testing to ascertain how dynamic loading affects strength development of structural bonding agents during curing.

2 Normative references

This European Standard incorporates by dated or undated reference, provisions from other publications. These normative references are cited at the appropriate places in the text, and the publications are listed hereafter. For dated references, subsequent amendments to or revisions of any of these publications apply to this European Standard only when incorporated in it by amendment or revision. For undated references the latest edition of the publication referred to applies (including amendments).

EN ISO 8501-1:2001, Preparation of steel substrates before application of paints and related products – Visual assessment of surface cleanliness – Part 1: Rust grades and preparation grades of uncoated steel substrates and of steel substrates after overall removal of previous coatings (ISO 8501-1:1988).

3 Principle

This Part of this European Standard uses a thick adherent shear test specimen as shown in figure 1. The test is performed by applying a dynamic tensile force along the longitudinal axis of the specimen during curing of the adhesive. Once the adhesive is cured the bonded joint is tested to failure in tension and its failure load compared with that of an unvibrated control specimen.

4 Equipment

- <https://standards.iteh.ai/catalog/standards/sist/1b3e9b9c-793e-42e7-9aa4-dc9dad713894-1-2004>
- [SIST EN 13894-1:2004](https://standards.iteh.ai/catalog/standards/sist/1b3e9b9c-793e-42e7-9aa4-dc9dad713894-1-2004)
- [standards.iteh.ai](https://standards.iteh.ai/catalog/standards/sist/1b3e9b9c-793e-42e7-9aa4-dc9dad713894-1-2004)
- 4.1 Steel adherents and loading plate as shown in figures 1 and 2.
 - 4.2 Grit blasting equipment.
 - 4.3 A tension testing machine of minimum 10kN capacity capable of applying load cycles with a frequency of 2 Hz with strain control, at a strain of 150 $\mu\text{m/m}$.
 - 4.4 A tension testing machine capable of applying static loads of up to 10 kN to an accuracy of $\pm 0,1$ kN.

5 Procedure**5.1 Preparation of test pieces**

The bonding surfaces of the steel adherents shall be degreased using a suitable degreasing agent and then grit blasted to grade SA 2 1/2 of EN ISO 8501-1:2001. The steel surface shall then be vacuumed to remove any dust and PVC tape applied to the four butting surfaces of the adherents in order to prevent any tensile bonding. Within 24 h, mix the adhesive in accordance with the manufacturer's instructions and apply to each of the prepared bonding surfaces such that when they are brought together a glueline thickness of $(1,0 \pm 0,1)$ mm is achieved.

5.2 Number of test specimens

The thick adherent shear test specimens are to be tested in pairs, using a loading plate as shown in figure 2. Three pairs of thick adherent shear test specimens are to be cured under dynamic load, and a further three pairs of thick adherent shear test specimens, acting as controls, are to be cured whilst stationary.

5.3 Testing

After the adhesive has been applied to the bonding surfaces of the adherents they shall immediately be bolted securely to the loading plate as shown in figure 2. The loading plate is then cycled between strains of $20 \mu\text{m/m}$ and $170 \mu\text{m/m}$ at a frequency of $(2 \pm 0,1)\text{Hz}$ using a sine wave function commencing 20 min after completion of mixing of the adhesive and continued for 48 hours, whilst the adhesive cures. Following a further five days of curing whilst stationary, the thick adherent shear test specimens shall be removed from the loading plate and then tested in tension at a rate of 1mm/min to determine the failure load reading to $0,1 \text{ kN}$ of each joint. The control specimens are to be cured stationary in the loading plate at zero strain for seven days prior to testing in tension. All curing and testing is to be conducted at $(21 \pm 2) \text{ }^\circ\text{C}$, care being taken to ensure that the dynamic loading apparatus does not raise the temperature above this limit.

5.4 Failure mode

Record the failure mode for each specimen as one of the following two types:

- Type A: cohesion failure within the adhesive;
- Type B: adhesion failure at one of the interfaces.

If there is a mix of these failure modes make a visual assessment to determine the surface area percentage for each type of failure and express this as a ratio, for example:

A:B = 70:30

5.5 Failure strength ratio

Calculate the failure strength for each specimen by dividing the failure load by the bonded area (225 mm^2). Hence, calculate the failure strength ratio by dividing the mean failure strength for all 6 specimens (3 pairs) subjected to cyclic straining by the mean failure strength for all 6 specimens (3 pairs) not subjected to cyclic straining.

iTeh STANDARD PREVIEW
(standards.iteh.ai)

EN 13894-1:2004
<https://standards.iteh.ai/catalog/standards/sist/165e9b9c-795e-42c7-9aa4-f9c5f9a8d77/sist-en-13894-1-2004>

EN 13894-1:2003 (E)**6 Test report**

The test report shall include the following information:

- a) reference to this test method standard;
- b) name and address of the test laboratory;
- c) identification number and date of the test report;
- d) name and address of the manufacturer or supplier of the product;
- e) name and identification marks or batch number of the product;
- f) date of supply of the product;
- g) date of preparation of the test specimens and any deviation from the prescribed method of preparation;
- h) conditions of storage of prepared test specimens prior to test;
- i) date of test;
- j) the failure load of each sample;
- k) the failure mode of each sample;
- l) the failure strength ratio.

ITeh STANDARD PREVIEW
(standards.iteh.ai)
<https://standards.iteh.ai/catalog/standards/sist/1b3e9b9c-793e-42e7-9aa4-f9c5f9a8d77/sist-en-13894-1-2004>

Dimensions in millimetres

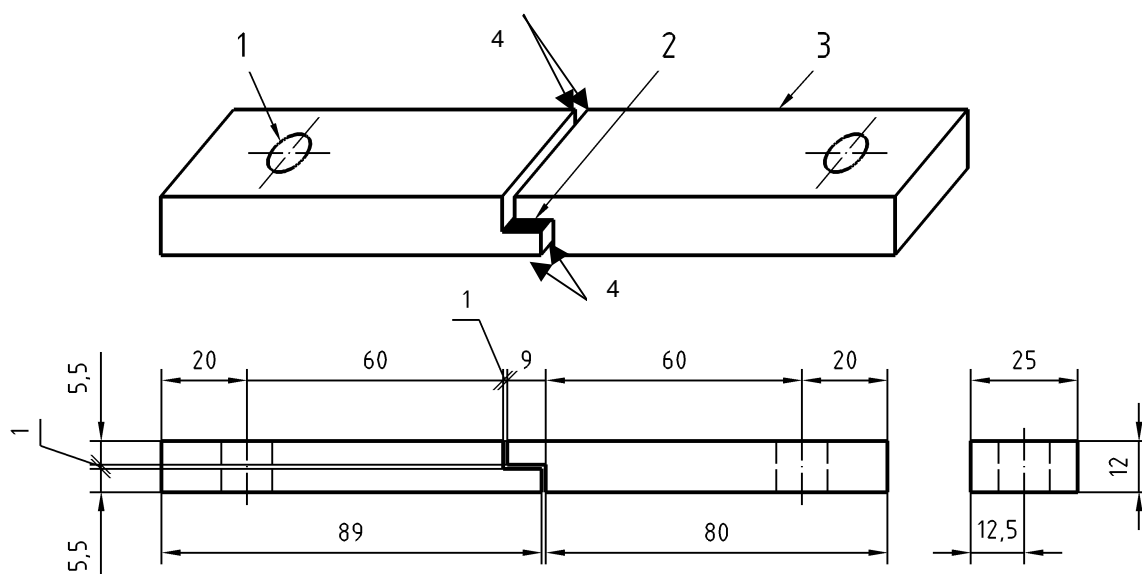
**Key**

- 1 Clearance hole for M12 threaded bar
- 2 Adhesive layer
- 3 25 mm × 12 mm steel bar
- 4 PVC tape on four butting surfaces

iTeh STANDARD PREVIEW
(standards.iteh.ai)

Figure 1 —Thick adherent shear test specimen
SIST EN 13894-1:2004

<https://standards.iteh.ai/catalog/standards/sist/1b3e9b9c-793e-42e7-9aa4-f9c5f9a8d77/sist-en-13894-1-2004>