

INTERNATIONAL  
STANDARDIZED  
PROFILE

**ISO/IEC**  
**ISP**  
**12068-2**

First edition  
1996-11-01

---

---

**Information technology — International  
Standardized Profile FDI 4 — Directory data  
definitions — Use of the Directory  
for OSI TP**

iTeh STANDARD PREVIEW

(standards.iteh.ai)

**Part 2:**  
FDI 42 — Enhanced naming and addressing

ISO/IEC ISP 12068-2:1996

<https://standards.iteh.ai/catalog/standards/sist/71379ee7-a052-4aa1-a965-5696c00f25da/iso-iec-isp-12068-2-1996>

*Technologies de l'information — Profil normalisé international FDI 4 —  
Définitions des données de l'Annuaire — Emploi de l'Annuaire  
pour OSI TP —*

*Partie 2: FDI 42 — Nommage et adressage améliorés*



Reference number  
ISO/IEC ISP 12068-2:1996(E)

**Contents**

## Foreword

## Introduction

- 1 Scope
  - 1.1 General
  - 1.2 Position within the taxonomy
  - 1.3 Scenario

- 2 Normative references

- 3 Definitions

- 4 Support level

- 5 Abbreviations

- 6 Conformance
  - 6.1 DSA conformance
  - 6.2 DUA conformance

- 7 DIT structure

- 8 Object classes

- 9 Attribute types

- 10 Attribute syntaxes

**iTeh STANDARD PREVIEW**  
**(standards.iteh.ai)**  
<https://standards.iteh.ai/catalog/standards/sist/71379ee7-a052-4aa1-a965-5696c00f25da/iso-iec-isp-12068-2-1996>

**Annexes**

- A Profile Requirements List for FDI 42
- B Profile Object Identifier

© ISO/IEC 1996

All rights reserved. Unless otherwise specified, no part of this publication may be reproduced or utilized in any form or by any means, electronic or mechanical, including photocopying and microfilm, without permission in writing from the publisher.

ISO/IEC Copyright Office • Case postale 56 • CH-1211 Genève 20 • Switzerland

Printed in Switzerland

## Foreword

ISO (the International Organization for Standardization) and IEC (the International Electrotechnical Commission) form the specialized system for worldwide standardization. National bodies that are members of ISO or IEC participate in the development of International Standards through technical committees established by the respective organization to deal with particular fields of technical activity. ISO and IEC technical committees collaborate in fields of mutual interest. Other international organizations, governmental or non-governmental, in liaison with ISO and IEC, also take part in the work.

In the field of information technology, ISO and IEC have established a joint technical committee, ISO/IEC JTC 1. In addition to developing International Standards, ISO/IEC JTC 1 has created a Special Group on Functional Standardization for the elaboration of International Standardized Profiles.

An International Standardized Profile is an internationally agreed, harmonized document which identifies a standard or group of standards, together with options and parameters, necessary to accomplish a function or set of functions.

Draft International Standardized Profiles are circulated to national bodies for voting. Publication as an International Standardized Profile requires approval by at least 75% of the national bodies casting a vote.

International Standardized Profile ISO/IEC ISP 12068-2 was prepared with the collaboration of

- Asia-Oceania Workshop (AOW);
- European Workshop for Open Systems (EWOS);
- OSE Implementors' Workshop (OIW);

ISO/IEC ISP 12068 consists of the following parts under the general title *Information technology - International Standardized Profile FDI 4 - Directory data definitions - Use of the Directory for OSI TP* :

- Part 1 : FDI 41 - *Basic naming and addressing*
- Part 2 : FDI 42 - *Enhanced naming and addressing*

Annexes A and B form an integral part of this part of ISO/IEC ISP 12068.

## Introduction

The concept and structure of International Standardized Profiles for Information Systems are laid down in the Technical Report ISO/IEC TR 10000. The purpose of an International Standardized Profile is to recommend when and how certain information technology standards shall be used. ISO/IEC ISP 12068 specifies application profile FDI 4 as defined in the Technical Report ISO/IEC TR 10000-2. ISO/IEC ISP 12068 is one of a set of International Standardized Profiles relating to the Directory (see ISO/IEC TR 10000-2). It specifies the schema of information for the OSI TP application to be stored in the Directory according to ISO/IEC 9594.

ISO/IEC ISP 10616 profiles information to be stored within the Directory which is common to a variety of applications. This ISP augments that information with OSI TP specific information.

Statements and conformance requirements stated in ISP for the information profiled by ISO/IEC ISP 10616 are also valid for the OSI TP specific information profiled by this ISP.

ISO/IEC ISP 12068 specifies the use of the Directory for OSI TP, using existing object class and attribute type definitions from the Directory specifications themselves, and additional definitions. These existing and additional definitions are also intended to support the use of the Directory by users of OSI TP applications.

## iTeh STANDARD PREVIEW (standards.iteh.ai)

[ISO/IEC ISP 12068-2:1996](https://standards.iteh.ai/catalog/standards/sist/71379ee7-a052-4aa1-a965-5696c00f25da/iso-iec-isp-12068-2-1996)

<https://standards.iteh.ai/catalog/standards/sist/71379ee7-a052-4aa1-a965-5696c00f25da/iso-iec-isp-12068-2-1996>

# Information technology - International Standardized Profile FDI 4 - Directory data definitions - Use of the Directory for OSI TP -

## Part 2 :

## FDI 42 - Enhanced naming and addressing

### 1 Scope

#### 1.1 General

ISO/IEC ISP 10616 profiles information to be stored within the Directory which is common to a variety of applications. ISO/IEC ISP 12068 augments this information with OSI TP specific information.

Statements and conformance requirements stated in ISO/IEC ISP 10616 for the information profiled by ISO/IEC ISP 10616 are also valid for the OSI TP specific information profiled by this international Standardized Profile.

ISO/IEC ISP 12068 specifies the use of the Directory, for OSI TP, using existing object class and attribute type definitions from the Directory specifications themselves, and additional definitions.

These existing and additional definitions are also intended to support the use of the Directory by users of OSI TP applications.

This part of ISO/IEC ISP 12068 defines those additional information which are needed to retrieve basic addressing information for applications using the OSI TP service.

#### 1.2 Position within the taxonomy

ISO/IEC ISP 12068 is identified in ISO/IEC TR 10000-2 as "Information technology - International Standardized Profile FDI 4 - Directory data definitions - Use of the Directory for OSI TP.

#### 1.3 Scenario

An OSI TP application, by means of its associated DUA, obtains Directory information by accessing directly or indirectly one or more DSAs of the Directory (see figure)

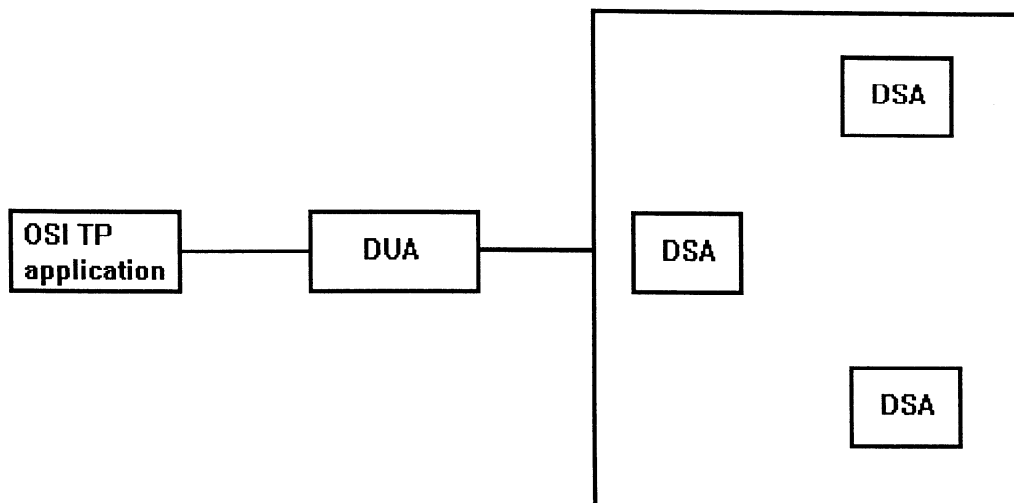

Figure 1 - Access of an OSI TP application to the Directory

## 2 Normative references

STANDARD PREVIEW  
(standards.iteh.ai)

The following documents contain provisions which, through reference in this text, constitute provisions of this part of ISO/IEC ISP 12068. At the time of publication, the editions indicated were valid. All documents are subject to revision, and parties to agreements based on this part of ISO/IEC ISP 12068 are warned against automatically applying any more recent editions of the documents listed below, since the nature of references made by ISPs to such documents is that they may be specific to a particular edition. Members of IEC and ISO maintain registers of currently valid International Standards and ISPs, and ITU-T maintains published editions of its current Recommendations.

ISO/IEC 9594-6:1990, *Information technology - Open Systems Interconnection - The Directory - Part 6 : Selected attribute types.*

ISO/IEC 9594-7:1990, *Information technology - Open Systems Interconnection - The Directory - Part 7 : Selected Object classes.*

ISO/IEC TR 10000-1:1995, *Information technology - Framework and taxonomy of International Standardized Profiles - Part 1 : General principles and documentation framework.*

ISO/IEC TR 10000-2:1995, *Information technology - Framework and taxonomy of International Standardized Profiles - Part 2 : Principles and taxonomy for OSI profiles.*

ISO/IEC 10026-1:1992, *Information technology - Open Systems Interconnection - Distributed Transaction Processing - Part 1 : OSI TP Model.*

ISO/IEC 10026-2:1996, *Information technology - Open Systems Interconnection - Distributed Transaction Processing - Part 2 : OSI TP Service.*

ISO/IEC 10026-3:1996, *Information technology - Open Systems Interconnection - Distributed Transaction Processing - Part 3 : Protocol specification.*

ISO/IEC ISP 10616:1995, *Information technology - International Standardized Profile FDI 11 - Directory data definitions - Common Directory Use (Normal).*

### 3 Definitions

For the purposes of this part of ISO/IEC ISP 12068 the definitions given in the referenced standards apply.

### 4 Support Level

To specify the support level of protocol features for this part of ISO/IEC ISP 12068, the following terminology is defined.

**4.2.1 mandatory; m** : Mandatory requirement for support. A feature (object class, attribute type, attribute syntax) is supported by a DSA implementation if the DSA is able to process the feature in accordance with the base standard or as specified ISO/IEC ISP (see also clauses 8, 9 and 10).

**4.2.2 optionally supported; o** : The support of the feature (object class, attribute type, attribute syntax) is left to the implementor of the DSA.

### 5 Abbreviations

DIB	Directory Information Base
DIT	Directory Information Tree
DSA	Directory Service Agent
DUA	Directory User Agent
ISP	International Standardized Profile
OID	Object Identifier
OSI TP	Open Systems Interconnection - Transaction Processing
PRL	Profile Requirements List
TPSU	TP Service User

### 6 Conformance

#### 6.1 DSA conformance

Conformance to this part ISO/IEC ISP 12068 implies conformance to ISO/IEC ISP 10616, i.e., as a precondition to conform to this part ISO/IEC ISP 12068, a Directory System Agent shall fulfill the conformance requirements as stated in ISO/IEC ISP 10616.

In addition, a Directory System Agent shall after suitable set up be capable of storing, modifying and retrieving entries which fulfill all of the following conditions :

- the entry lies within the scope of the minimum set of structure and naming elements specified in clause 7 ;
- the entry's object classes are part of the set of mandatory object classes (specified in A.6.4.1) and the subset of optional object classes (see ISO/IEC ISP 10616, A.6.4.1) for which support is claimed for the DSA ;

- the entry's attributes are part of the set of mandatory attribute types (as specified in A.6.4.2) and the subset of optional attribute types (see ISO/IEC ISP 10616, A.6.4.2) for which support is claimed for the DSA.

The requirements formulated in ISO/IEC ISP 10616 with respect to supported object classes, supported attribute types and supported attribute syntaxes according to ISO/IEC ISP 10616 are also valid for the additional supported object classes, supported attribute types and supported attribute syntaxes according to this part of ISO/IEC ISP 12068.

## 6.2 DUA conformance

DUAs typically need schema information as outlined in this part of ISO/IEC ISP 12068 to support Use of the Directory for OSI TP. However, this part of ISO/IEC ISP 12068 makes no statements about DUA conformance.

## 7 DIT structure

The purpose of this clause is to relate information specified in ISO/IEC ISP 12068 to the minimum set of structure and naming elements defined in ISO/IEC ISP 10616 and thus to provide locations for entries of selected object classes.

The DIT structure which shall as a minimum be supported by implementations claiming conformance to ISO/IEC ISP 12068 is that defined in ISO/IEC ISP 10616 and in clause 8 and 9.

The DIT structure which shall as a minimum be supported by implementations claiming conformance to ISO/IEC ISP 12068 is the superset of

- structure elements listed in ISO/IEC ISP 10616, and
- structure elements listed in A.6.5.1.

This DIT structure is supported in the sense that a conformant DSA shall be capable of storing, modifying and retrieving entries which are part of a tree with this structure (for a more formal definition see ISO/IEC ISP 10616).

## 8 Object classes

The following object class shall be supported in addition to those specified in ISO/IEC ISP 10616:

- tpsu

To define the application entity objects that are the objects stored in the Directory describing OSI TP entities, it is necessary to have Object Identifiers to identify the various objects and attributes.

In the following definitions the Object Identifier used as the parent vertex for the definition of object identifiers for TP object classes is:

```
osiTpObjectClass ::= OBJECT IDENTIFIER {iso(1) standard(0) fdi4(12068) objectClass(6)}
"OSI TP object class"
```



## 8.1 tpsu

The tpsu structural object class is used to describe the information relative to a TP Service User.

```

tpsu OBJECT CLASS
  SUBCLASS OF top
  KIND structural
  MUST CONTAIN {
    tpsuTitle,
    tpRoles,
    applicationEntities}
  MAY CONTAIN {
    tpApplicationContext,
    tpSymbolicNames,
    tpHumanReadableInformation }

  ::= {osiTpObjectClass 1}

```

## 9 Attribute types

The following attribute types shall be supported in addition to those specified in ISO/IEC ISP 10616:

- applicationEntities
- tpApplicationContext
- tpHumanReadableInformation
- tpRoles
- tpsuTitle
- tpSymbolicNames

ITeH STANDARD PREVIEW  
 (standards.iteh.ai)  
 ISO/IEC ISP 12068-2:1996  
<https://standards.iteh.ai/catalog/standards/sist/71379ee7-a052-4aa1-a965-5696c00f25da/iso-iec-isp-12068-2-1996>

Each of the additionally defined attributes requires an Object Identifier to identify it, and the parent vertex definition for these OIDs is:

```

osiTpAttributeType ::= OBJECT IDENTIFIER
  {iso(1) standard(0) fdi4(12068) attributeType(5)}
  "OSI TP attribute type"

```

### 9.1 TPSU Title

The TPSU Title attribute type specifies the name used to designate the user of OSI TP services in an application process.

```

tpsuTitle ATTRIBUTE
  WITH SYNTAX TPSU-title
  EQUALITY MATCHING RULE
  SINGLE VALUE TRUE
  ID {tpAttributeType 1}

```