**Paints and varnishes — Determination
of film hardness by pencil test**

*Peintures et vernis — Détermination de la dureté du feuillet
par l'essai de dureté crayon*

iTeh STANDARD PREVIEW
(standards.iteh.ai)

[ISO 15184:1998](https://standards.iteh.ai/catalog/standards/sist/c56822f9-812b-43c6-a3b3-854e7421643e/iso-15184-1998)

<https://standards.iteh.ai/catalog/standards/sist/c56822f9-812b-43c6-a3b3-854e7421643e/iso-15184-1998>



ISO (the International Organization for Standardization) is a worldwide federation of national standards bodies (ISO member bodies). The work of preparing International Standards is normally carried out through ISO technical committees. Each member body interested in a subject for which a technical committee has been established has the right to be represented on that committee. International organizations, governmental and non-governmental, in liaison with ISO, also take part in the work. ISO collaborates closely with the International Electrotechnical Commission (IEC) on all matters of electrotechnical standardization.

Draft International Standards adopted by the technical committees are circulated to the member bodies for voting. Publication as an International Standard requires approval by at least 75 % of the member bodies casting a vote.

~~International Standard~~ ISO 15184 was prepared by Technical Committee ISO/TC 35, Subcommittee SC 9, *General test methods for paints and varnishes*.

Annex A forms an integral part of this International Standard.

iTeh STANDARD PREVIEW (standards.iteh.ai)

ISO 15184:1998

<https://standards.iteh.ai/catalog/standards/sist/c56822f9-812b-43c6-a3b3-854e7421643e/iso-15184-1998>

© ISO 1998

All rights reserved. Unless otherwise specified, no part of this publication may be reproduced or utilized in any form or by any means, electronic or mechanical, including photocopying and microfilm, without permission in writing from the publisher.

International Organization for Standardization
Case postale 56 • CH-1211 Genève 20 • Switzerland
Internet iso@iso.ch

Foreword

1 Scope

1.1 This International Standard is one of a series of standards dealing with the sampling and testing of paints, varnishes and related products.

It specifies a method for determining the film hardness by pushing pencils of known hardness over the film.

The test can be performed on a single coating of a paint, varnish or related product, or on the upper layer of a multicoat system.

1.2 This rapid, inexpensive test has been found to be useful in comparing the pencil hardness of different coatings.

It is more useful in providing relative ratings for a series of coated panels exhibiting significant differences in pencil hardness.

ISO 15184:1998

The method is applicable only to smooth surfaces.

2 Normative references

The following standards contain provisions which, through reference in this text, constitute provisions of this International Standard. At the time of publication, the editions indicated were valid. All standards are subject to revision, and parties to agreements based on this International Standard are encouraged to investigate the possibility of applying the most recent editions of the standards indicated below. Members of IEC and ISO maintain registers of currently valid International Standards.

ISO 1512:1991, *Paint and varnishes — Sampling of products in liquid or paste form.*

ISO 1513:1992, *Paints and varnishes — Examination and preparation of samples for testing.*

ISO 1514:1993, *Paints and varnishes — Standard panels for testing.*

ISO 2808:1997, *Paints and varnishes — Determination of film thickness.*

3 Definition

For the purposes of this International Standard, the following definition applies:

3.1 pencil hardness: The resistance of the surface of a paint film to marking, or the formation of some other defect, as a result of the action of a pencil with a lead of specified dimensions, shape and hardness which is pushed across the surface.

Paints and varnishes — Determination of film hardness by pencil test

Marking by pencil leads covers a range of defects in the surface of the paint film.

These defects are defined as follows:

- a) Plastic deformation: a permanent indentation in the paint surface without cohesive fracture.
- b) Cohesive fracture: the presence of a visible scratch or rupture in the surface of the paint film, material having been removed from the paint film.
- c) Combinations of the above.

These defects can occur simultaneously.

4 Principle

The product or system under test is applied at uniform thickness to flat panels of uniform surface texture.

After drying/curing, the pencil hardness is determined by pushing pencils of increasing hardness over the paint film, with the panel in a horizontal position.

During the test, the pencil is mounted so that it presses down on the paint surface at an angle of 45° with a load of 750 g.

The hardness of the pencils is increased in steps until the coating is marked by defects of the kind defined in 3.1.

5 Required supplementary information

For any particular application, the test method specified in this International Standard needs to be completed by supplementary information. <https://standards.iteh.ai/catalog/standards/sist/c56822f9-812b-43c6-a3b3-854e7421643e/iso-15184-1998>

The items of supplementary information are given in annex A.

6 Apparatus

6.1 Test instrument: The test is best performed using a mechanical device. An example of a suitable device is shown in figure 1 (see also note).

NOTE — Although the test is preferably performed using a mechanical device, it can also be performed by hand. Other types of test instrument may also be used, provided they give similar relative rating results.

The device shown consists of a metal block fitted with two wheels, one on each side. In the middle of the metal block, there is a cylindrical hole inclined at an angle of $(45 \pm 1)^\circ$.

With the help of a clamp, pencils can be fixed in the instrument so that they are always in the same position.

Mounted on the top of the instrument is a level which is used to ensure that the test is carried out with the instrument horizontal.

The instrument shall be designed so that, with the instrument in the horizontal position, the tip of the pencil exerts a load of (750 ± 10) g on the paint surface.

6.2 Set of wood drawing pencils, of the following hardnesses (see note):

9B - 8B - 7B - 6B - 5B - 4B - 3B - 2B - B - HB - F - H - 2H - 3H - 4H - 5H - 6H - 7H - 8H - 9H

Softer _____ Harder

NOTE — Pencils made by various manufacturers may be used by agreement between the interested parties, provided they give similar relative rating results.

Some examples of pencil makes and manufacturers which have been found suitable are as follows:

- Microtomic, manufactured by Faber Castell;
- Turquoise T-2375, manufactured by Empire Berol, USA;
- KOH-I-NOOR, type 1500, manufactured by Hardtmuth AG;
- Uni, manufactured by the Mitsubishi Pencil Co.

For comparative testing, it is recommended that pencils from the same manufacturer be used. Variations may be found between manufacturers and between batches from the same manufacturer.

6.3 Special mechanical sharpener¹⁾, which will remove the wood only, leaving the cylindrical pencil lead intact (see figure 2).

6.4 Abrasive paper, grit No. 400.

6.5 Soft cloth or swab of cotton wool (to clean the panel after the test, using a solvent to which the coating is inert).

ITCh STANDARD PREVIEW
(standards.itech.ai)

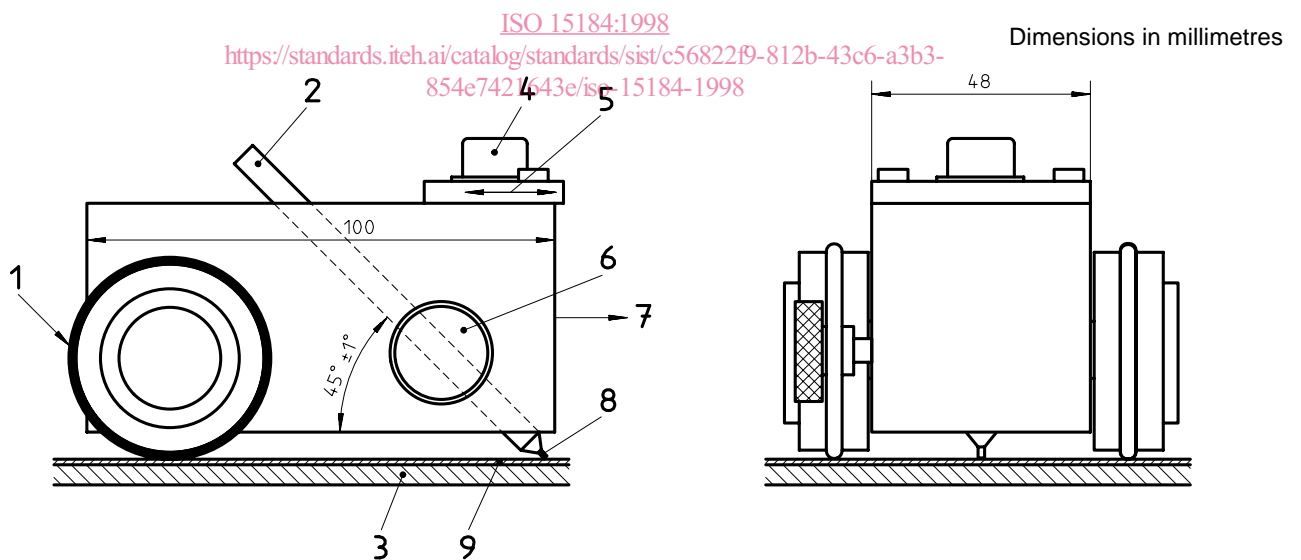

Key

- | | |
|-------------------------|-------------------------------------|
| 1 Rubber O-ring | 6 Clamp |
| 2 Pencil | 7 Direction of motion of instrument |
| 3 Substrate | 8 Pencil lead |
| 4 Level | 9 Paint film |
| 5 Small, movable weight | |

1) For example, a Staedler 510.27 metal pencil sharpener with a removable blade, available from Staedler (UK) Ltd, Pontyclun, Mid-Glamorgan, CF72 8YJ, United Kingdom, has been found suitable for this purpose.

Dimensions in millimetres

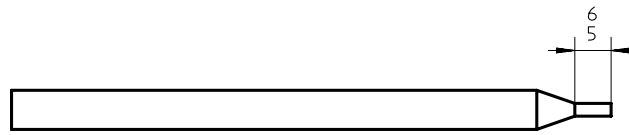

Figure 2 — Schematic view of pencil after sharpening

7 Sampling

Take a representative sample of the product to be tested (or of each product in the case of a multicoat system), as described in ISO 1512.

Examine and prepare each sample for testing, as described in ISO 1513.

8 Test panels

8.1 Substrate

Unless otherwise agreed, select the substrate from one of those described in ISO 1514, using, where possible, the same type of material as will be used in practice. The substrate panels shall be plane and free from distortion.

8.2 Shape and dimensions

The shape and dimensions of the test panels shall be such that, during the test, the panel will stay in the horizontal position.

<https://standards.iteh.ai/catalog/standards/sist/c56822f9-812b-43c6-a3b3-854e7421643e/iso-15184-1998>

8.3 Preparation and coating

Unless otherwise agreed, prepare each test panel in accordance with ISO 1514 and then coat it by the specified method with the product or system under test.

8.4 Drying and conditioning

Dry (or stove) and age, if applicable, each coated test panel for the specified time under the specified conditions. Before testing, condition the coated panels at (23 ± 2) °C and a relative humidity of (50 ± 5) %, unless otherwise agreed, for a minimum period of 16 h.

8.5 Thickness of coating

The thickness of the coating shall be as specified or as agreed between the interested parties. Determine the thickness of the coating by one of the procedures specified in ISO 2808.

9 Procedure

9.1 Carry out the test at a temperature of (23 ± 2) °C and a relative humidity of (50 ± 5) %, unless otherwise agreed.

9.2 Remove approximately 5 mm to 6 mm of wood from the point of each pencil using the special mechanical sharpener (6.3), being careful to leave an undisturbed, unmarked, smooth cylinder of pencil lead.

9.3 The tip of the lead shall be squared by holding the pencil in a vertical position and moving the pencil back and forth over abrasive paper (6.4), maintaining an angle of 90°. Continue until a flat, smooth, circular cross-section is obtained, free from chips or nicks in the edges.

Repeat this procedure each time a pencil is used.

9.4 Place the coated panel on a level, firm, horizontal surface.

Insert a pencil in the test instrument (6.1) and clamp it in position so that the instrument is horizontal with the tip of the pencil resting on the surface of the paint film (see figure 1).

9.5 Immediately after the tip of the pencil has come to rest on the coating, push the test panel, in the direction away from the operator, at a speed of 0,5 mm/s to 1 mm/s for a distance of at least 7 mm.

9.6 Unless otherwise agreed, inspect the coating after 30 s with the naked eye for marking of the kind defined in 3.1.

The damage can be assessed more easily after cleaning all fragments of pencil lead from the paint surface using a soft cloth or swab of cotton wool (6.5) and an inert solvent. If this is done, take care that the solvent does not affect the hardness of the coating in the test area.

By agreement, a microscope (magnification $\times 6$ to $\times 10$) may be used to assess the damage. If a microscope is used, this shall be reported in the test report.

If no marking has occurred, repeat the test (9.3 to 9.6) without overlap of the test areas, moving up the hardness scale until marking occurs over a distance of at least 3 mm.

If marking has occurred, repeat the test (9.3 to 9.6) down the hardness scale until marking no longer occurs.

Determine which of the defects of the kind defined in 3.1 has been produced.

The hardness of the hardest pencil which does not mark the coating is the so-called pencil hardness.

By agreement, the test can also be carried out to determine the minimum pencil hardness which does not cause a cohesive fracture (the so-called "gouge" hardness as defined in ASTM D 3363-92a, *Film hardness by pencil test*). If the test is done this way, this shall be reported in the test report.

9.7 Carry out the test in duplicate. If the two results differ by more than one unit of pencil hardness, discard them and repeat the test.

10 Precision

Use the following criteria, based on ASTM D 3363-92a, to judge the acceptability of results (confidence level 95 %):

Repeatability: Two results obtained by two different operators within the same laboratory using the same pencils and panels should be considered suspect if they differ by more than one pencil unit on the scale given in 6.2.

Reproducibility: Two results, each the mean of at least two determinations, obtained by operators in different laboratories using the same pencils and panels, or different pencils and the same panels, should be considered suspect if they differ by more than one pencil unit on the scale given in 6.2.

Bias: Since there is no acceptable material suitable for determining the bias for the procedure in this test method, bias cannot be determined.

11 Test report

The test report shall contain at least the following information:

- a) all details necessary to identify the product tested;
- b) a reference to this International Standard (ISO 15184);
- c) the items of supplementary information referred to in annex A;
- d) a reference to the international or national standard, product specification or other document supplying the information referred to in c);
- e) the make and manufacturer of the pencil used;
- f) the result of the test, including, if agreed between the interested parties, a description of the kinds of defect defined in 3.1 which actually occurred;
- g) the magnification of the microscope, if used;
- h) any deviation from the test method specified;
- i) the date of the test.

iTeh STANDARD PREVIEW
(standards.iteh.ai)

ISO 15184:1998

<https://standards.iteh.ai/catalog/standards/sist/c56822f9-812b-43c6-a3b3-854e7421643e/iso-15184-1998>

Annex A (normative)

Required supplementary information

The items of supplementary information listed in this annex shall be supplied as appropriate to enable the method to be carried out.

The information required should preferably be agreed between the interested parties and may be derived, in part or totally, from an international or national standard or other document related to the product under test.

- a) The material, dimensions and surface preparation of the substrate.
- b) The method of application of the test coating to the substrate.
- c) The duration and conditions of drying (or stoving) and ageing (if applicable) of the coating before testing.
- d) The thickness, in micrometres, of the dry coating and method of measurement in accordance with ISO 2808, and whether it is a single coating or a multi coat system.
- e) The temperature and relative humidity of the test, if different from those specified in 9.1.

[ISO 15184:1998](https://standards.iteh.ai/catalog/standards/sist/c56822f9-812b-43c6-a3b3-854e7421643e/iso-15184-1998)

<https://standards.iteh.ai/catalog/standards/sist/c56822f9-812b-43c6-a3b3-854e7421643e/iso-15184-1998>