



SLOVENSKI STANDARD
SIST EN 15471:2008
01-januar-2008

I hŕ_c]b^yb]`bUzb]`d`]b]`È8c`c Yj Ub^YfUhtcd`^yb]` `cghUb_cj `È
J]gc_chYa dYfUi fbU[fUj]a Yf]g_Ua YtcXU

Liquefied petroleum gases - Determination of dissolved residues - High-temperature gravimetric method

Flüssiggas - Bestimmung der gelösten Rückstände - Gravimetrisches Hochtemperaturverfahren

iTeh STANDARD PREVIEW

Gaz de pétrole liquéfié - Détermination des résidus dissous - Méthode gravimétrique a haute température

[SIST EN 15471:2008](https://standards.iteh.ai/catalog/standards/sist/5a3ec136-e6a9-4c49-884d-550566316fb6/sist-en-15471-2008)

<https://standards.iteh.ai/catalog/standards/sist/5a3ec136-e6a9-4c49-884d-550566316fb6/sist-en-15471-2008>
Ta slovenski standard je istoveten z: EN 15471:2007

ICS:

75.160.30 Plinska goriva Gaseous fuels

SIST EN 15471:2008 **en,de**

iTeh STANDARD PREVIEW
(standards.iteh.ai)

SIST EN 15471:2008

<https://standards.iteh.ai/catalog/standards/sist/5a3ec136-e6a9-4c49-884d-5563b0516fb6/sist-en-15471-2008>

ICS 75.160.10

English Version

Liquefied petroleum gases - Determination of dissolved residues - High-temperature gravimetric method

Gaz de pétrole liquéfiés - Détermination des résidus
dissous - Méthode gravimétrique à haute température

Flüssiggas - Bestimmung der gelösten Rückstände -
Gravimetrisches Hochtemperaturverfahren

This European Standard was approved by CEN on 7 October 2007.

CEN members are bound to comply with the CEN/CENELEC Internal Regulations which stipulate the conditions for giving this European Standard the status of a national standard without any alteration. Up-to-date lists and bibliographical references concerning such national standards may be obtained on application to the CEN Management Centre or to any CEN member.

This European Standard exists in three official versions (English, French, German). A version in any other language made by translation under the responsibility of a CEN member into its own language and notified to the CEN Management Centre has the same status as the official versions.

CEN members are the national standards bodies of Austria, Belgium, Bulgaria, Cyprus, Czech Republic, Denmark, Estonia, Finland, France, Germany, Greece, Hungary, Iceland, Ireland, Italy, Latvia, Lithuania, Luxembourg, Malta, Netherlands, Norway, Poland, Portugal, Romania, Slovakia, Slovenia, Spain, Sweden, Switzerland and United Kingdom.

[SIST EN 15471:2008](https://standards.iteh.ai/catalog/standards/sist/5a3ec136-e6a9-4c49-884d-5563b0516fb6/sist-en-15471-2008)

<https://standards.iteh.ai/catalog/standards/sist/5a3ec136-e6a9-4c49-884d-5563b0516fb6/sist-en-15471-2008>



EUROPEAN COMMITTEE FOR STANDARDIZATION
COMITÉ EUROPÉEN DE NORMALISATION
EUROPÄISCHES KOMITEE FÜR NORMUNG

Management Centre: rue de Stassart, 36 B-1050 Brussels

Contents

Page

Foreword.....	3
1 Scope	4
2 Normative reference	4
3 Terms and definitions	4
4 Principle.....	4
5 Reagents.....	4
6 Apparatus	5
7 Sampling.....	6
8 Procedure	6
8.1 Sampling.....	6
8.2 Evaporation of the LPG.....	7
8.3 Jet evaporation procedure.....	7
9 Calculation.....	8
10 Expression of results.....	8
11 Precision.....	8
11.1 General.....	8
11.2 Repeatability, <i>r</i>	8
11.3 Reproducibility, <i>R</i>	9
Bibliography.....	10

iTeh STANDARD PREVIEW
 (standards.itech.ai)
 SIST EN 15471:2008
<https://standards.itech.ai/catalog/standards/sist/5a3ec136-e6a9-4c49-884d-5563b05101b6/sist-en-15471-2008>

Foreword

This document (EN 15471:2007) has been prepared by Technical Committee CEN/TC 19 "Gaseous and liquid fuels, lubricants and related products of petroleum, synthetic and biological origin", the secretariat of which is held by NEN.

This European Standard shall be given the status of a national standard, either by publication of an identical text or by endorsement, at the latest by May 2008, and conflicting national standards shall be withdrawn at the latest by May 2008.

Attention is drawn to the possibility that some of the elements of this document may be the subject of patent rights. CEN [and/or CENELEC] shall not be held responsible for identifying any or all such patent rights.

According to the CEN/CENELEC Internal Regulations, the national standards organizations of the following countries are bound to implement this European Standard: Austria, Belgium, Bulgaria, Cyprus, Czech Republic, Denmark, Estonia, Finland, France, Germany, Greece, Hungary, Iceland, Ireland, Italy, Latvia, Lithuania, Luxembourg, Malta, Netherlands, Norway, Poland, Portugal, Romania, Slovakia, Slovenia, Spain, Sweden, Switzerland and the United Kingdom.

iTeh STANDARD PREVIEW (standards.iteh.ai)

SIST EN 15471:2008

<https://standards.iteh.ai/catalog/standards/sist/5a3ec136-e6a9-4c49-884d-5563b0516fb6/sist-en-15471-2008>

1 Scope

This Standard specifies a method, for determining the residual matter in liquefied petroleum gases (LPG), which remains after evaporation at 105 °C. This material represents those products deposited in car LPG vaporizers that are subject to a temperature equal to or greater than the boiling temperature of water. The range of determination extends from 50 mg/kg to 100 mg/kg. Higher concentrations can be determined by adjusting the sample size.

The precision data of the method have been determined from 20 mg/kg to 100 mg/kg, with samples amount from 100 g to 50 g.

This method has been developed as a potential replacement of the commonly used method EN ISO 13757 [1]. The advantages of the method are that a small quantity of LPG (100 ml) is required.

NOTE An alternative European Standard, EN 15470 [2], with the same scope, specifies a gas chromatography method with slightly better fidelity.

WARNING — Use of this method involves hazardous materials and operations. It is the responsibility of the user to establish appropriate safety and health precautions. All handling must be performed in a fume hood.

2 Normative reference

The following referenced documents are indispensable for the application of this document. For dated references only the edition cited applies. For undated references, the latest edition of the referenced document (including any amendments) applies.

EN ISO 4257, *Liquefied petroleum gases - Method of sampling (ISO 4257:2001)*

<https://standards.iteh.ai/catalog/standards/sist/5a3ec136-e6a9-4c49-884d-5563b0516fb6/sist-en-15471-2008>

3 Terms and definitions

For the purposes of this document, the following term and definition applies.

3.1 liquefied petroleum gas (LPG)
petroleum gas that can be stored and/or handled in the liquid phase under moderate conditions of pressure and at ambient temperature, consisting predominantly of propane, butanes, with small proportions of propene, butenes and pentanes/pentenes

4 Principle

A known mass of LPG is sampled and concentrated by evaporation. The concentrate is transferred into a beaker of 100 ml capacity and then evaporated by jet evaporation under controlled conditions of temperature and airflow. The oily residue remaining after this procedure is cooled and weighed.

5 Reagents

- 5.1 n-heptane, analytical grade.
- 5.2 2-propanol, technical grade, for the cooling bath.
- 5.3 Solid carbon dioxide, for the cooling bath.

5.4 **Air**, supply of filtered air at a pressure not more than 34,5 kPa.

5.5 **propanone (acetone)**

6 Apparatus

6.1 **Sample cylinder**, made of stainless steel, fitted with two stainless steel valves conforming to EN ISO 4257 and having a maximum service pressure of 3 MPa and a minimum capacity of 1 l. This cylinder is used to sample the LPG, of which the dissolved residues are to be determined.

6.2 **In-line filter support**, made of stainless steel and for use at suitable high pressure.

6.3 **Filter discs**, plain membrane with nominal pore dimension of 0,8 μm .

6.4 **Cooling coil**, made by coiling 4 m of stainless steel tube of external diameter 6 mm and internal diameter 4 mm onto a mandrel of a diameter of approximately 50 mm and fitted with the necessary connections (see 3 in Figure 2).

6.5 **Cooling bath**, comprising a Dewar flask, three-quarters filled with an appropriate liquid, e.g. 2-propanol (5.2) cooled with solid carbon dioxide, to achieve a temperature of about - 60 °C.

6.6 **Beaker**, made of glass, with a capacity of 1 l.

6.7 **Ebullition regulating rod**, made of glass and a length of about 28 cm.

6.8 **Beaker**, made of glass and with a capacity 100 ml.

6.9 Balances

6.9.1 For weighing the sample cylinder (6.1), balance with a range of 10 kg minimum, accurate to within ± 1 g or better.

6.9.2 For weighing the beaker (6.8), balance with a range of 200 g, accurate to within $\pm 0,1$ mg or better.

6.10 **Cabinet drier**, suitable for the preparation of the 100 ml beaker (6.8).

6.11 **Desiccator**.

6.12 **Apparatus**, for determining evaporation residues by air jet evaporation according to Figure 1 (for further information see ASTM D 381 [3]).

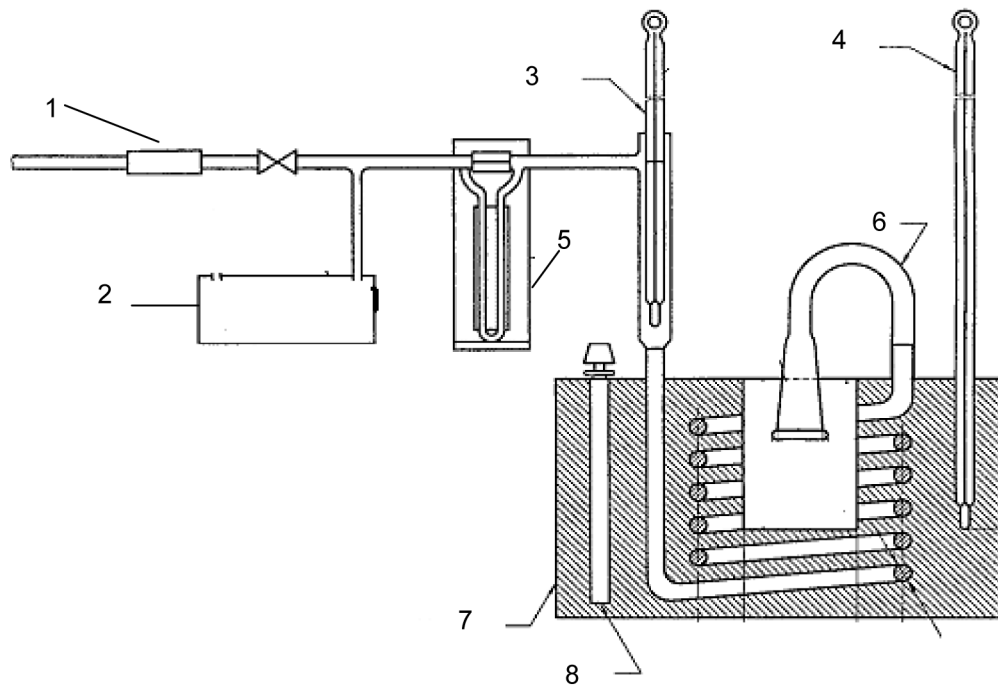

Key

- | | |
|------------------------------------|----------------------|
| 1. dry air supply | 5. flow indicator |
| 2. dry and clean steam supply | 6. removable adaptor |
| 3. thermometer and well (optional) | 7. heating block |
| 4. thermometer | 8. thermo-regulator |

SIST EN 15471:2008

Figure 1 — Apparatus for determining oily residues by jet evaporation

7 Sampling

Samples shall be taken as described in EN ISO 4257 and/or in accordance with the requirements of national standards or regulations for the sampling of automotive LPG.

8 Procedure

8.1 Sampling

Assemble the apparatus, as shown in Figure 2, and operate the following instructions:

- slowly shake the sample cylinder (6.1) containing the LPG to be analysed, in order to mix the contents;
- connect the lower valve of the sample cylinder to the in-line filter (6.2);
- purge and fill the in-line filter and the cooling coil with the LPG to be analyzed;
- close the lower valve of the sample cylinder;
- disconnect the in-line filter from the sample cylinder and weigh the sample cylinder to obtain its mass m_1 in grams;
- reconnect the sample cylinder to the purged in-line filter and cooling coil;

- g) position the 1 l beaker (6.6) and open the lower valve of the sample cylinder to obtain a steady flow of LPG sample into the beaker, until a mass of approximately 250 g is obtained;
- h) close the lower valve of the sample cylinder;
- i) disconnect the in-line filter from the sample cylinder and weigh the sample cylinder once more to obtain the post sample cylinder mass m_2 in grams.

The test sample mass, m_s , in grams, is determined by subtraction:

$$m_s = m_1 - m_2 \quad (1)$$

8.2 Evaporation of the LPG

Place the beaker with the sample (see 8.1) into an explosion-proof hood. Leave to evaporate until there is no visible volume of liquid left in the beaker.

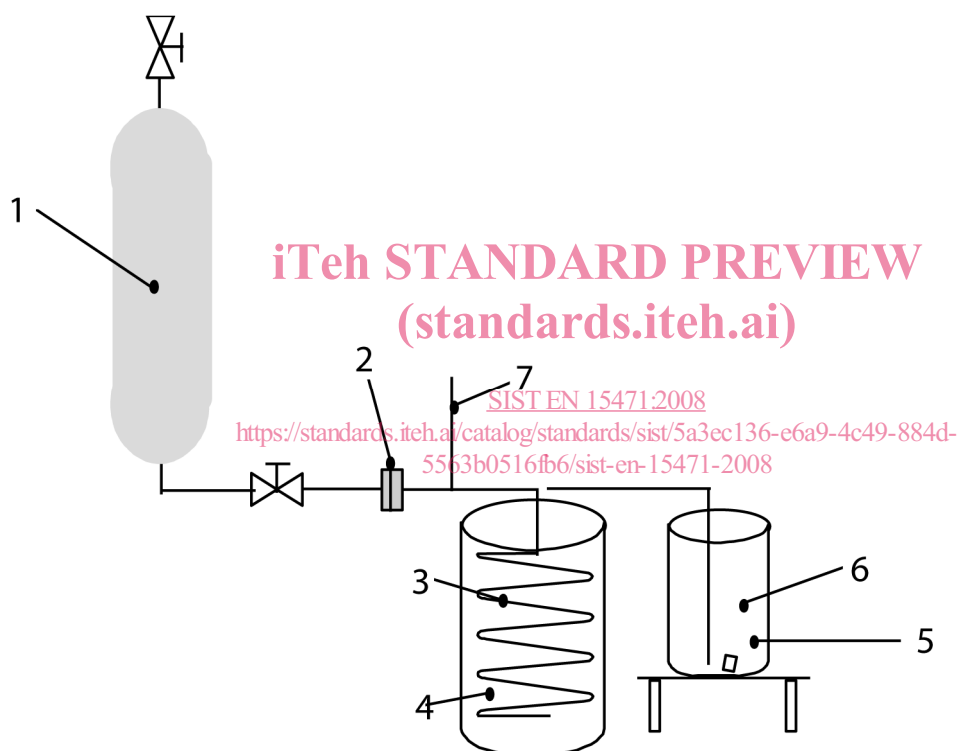

Key

- | | |
|--|------------------------------------|
| 1. sample cylinder with two valves (6.1) | 5. 1 l beaker (6.6) |
| 2. in-line filter support (6.2) | 6. ebullition regulating rod (6.7) |
| 3. stainless steel cooling coil (see 6.4) | 7. earthing |
| 4. Dewar flask filled as stipulated in 6.5 | |

Figure 2 — Sampling assembly

8.3 Jet evaporation procedure

The 100 ml beaker (6.8) is washed/rinsed with acetone (5.5) and distilled water and then dried at 105 °C for 30 min.