

5 YfcbUj h_U!'NU_cj bY'a UhWZgUa cnUdJfUbYzcXdcfbY'dfchJ[cfJj i žHgb^YbYž
dfYa] bYžXj cglfUbg_Yžn'nj fhbc'nUj U'UghY'j]'U_Yž]n'_cfcn]g_c'cXdcfbY[U'Y_`Už
dUgJj JfUbYža UnUbY'n'AcG&ža Yfg_UgYf]U!'?'Ug]Z_UW'U.'-\$A DUfdJ]'hYa dYfUi fJ
c_c`jWt#/#\$š7

Aerospace series - Nuts, anchor, self-locking, fuel resistant, sealing, floating, two lug,
with counterbore, in corrosion resisting steel, passivated, MoS2 lubricated, metric series
- Classification: 900 MPa (at ambient temperature)/120 °C

iTeh STANDARD PREVIEW

Luft- und Raumfahrt - Anniemuttern, selbstsichernd, kraftstoffbeständig, druckdicht,
beweglich, beiderseitiger Flansch, mit zylindrischer Aussenkung, aus
korrosionsbeständigem Stahl, passiviert, MoS2-geschmiert, metrische Reihe - Klasse:
900 MPa (bei Raumtemperatur)/120 °C

<http://standards.iteh.ai/catalog/standards/sist/d5fabd9d-ed1e-4c6e-9c96-1f7901ca3133/sist-en-2881-2009>

Série aérospatiale - Écrous à river, à freinage interne, étanches au carburant, flottants,
double patte, avec chambrage, en acier résistant à la corrosion, passivés, lubrifiés
MoS2, série métrique - Classification: 900 MPa (à température ambiante)/120 °C

Ta slovenski standard je istoveten z: EN 2881:2006

ICS:

49.030.30 Matice Nuts

SIST EN 2881:2009 en,de

iTeh STANDARD PREVIEW
(standards.iteh.ai)

SIST EN 2881:2009

<https://standards.iteh.ai/catalog/standards/sist/d5fabd9d-ed1e-4c6e-9c96-1f7901ca3133/sist-en-2881-2009>

EUROPEAN STANDARD

EN 2881

NORME EUROPÉENNE

EUROPÄISCHE NORM

May 2006

ICS 49.030.30

English Version

Aerospace series - Nuts, anchor, self-locking, fuel resistant, sealing, floating, two lug, with counterbore, in corrosion resisting steel, passivated, MoS2 lubricated - Classification: 900 MPa (at ambient temperature) / 120 C

Série aérospatiale - Écrous à river, à freinage interne, étanches au carburant, flottants, double patte, avec chambrage, en acier résistant à la corrosion, passivés, lubrifiés MoS2, série métrique - Classification : 900 MPa (à température ambiante) / 120 C

Luft- und Raumfahrt - Anniemuttern, selbstsichernd, druckdicht, kraftstoffbeständig, beweglich, beiderseitiger Flansch, mit zylindrischer Aussenkung, aus korrosionsbeständigem Stahl, passiviert, MoS2-geschmiert - Klasse: 900 MPa (bei Raumtemperatur) / 120 C

This European Standard was approved by CEN on 6 February 2006.

CEN members are bound to comply with the CEN/CENELEC Internal Regulations which stipulate the conditions for giving this European Standard the status of a national standard without any alteration. Up-to-date lists and bibliographical references concerning such national standards may be obtained on application to the Central Secretariat or to any CEN member.

This European Standard exists in three official versions (English, French, German). A version in any other language made by translation under the responsibility of a CEN member into its own language and notified to the Central Secretariat has the same status as the official versions.

<https://standards.iteh.ai/catalog/standards/sist/d5fabd9d-ed1e-4c6e-9c96-59113123belgium/2881-2006>

CEN members are the national standards bodies of Austria, Belgium, Cyprus, Czech Republic, Denmark, Estonia, Finland, France, Germany, Greece, Hungary, Iceland, Ireland, Italy, Latvia, Lithuania, Luxembourg, Malta, Netherlands, Norway, Poland, Portugal, Romania, Slovakia, Slovenia, Spain, Sweden, Switzerland and United Kingdom.



EUROPEAN COMMITTEE FOR STANDARDIZATION
COMITÉ EUROPÉEN DE NORMALISATION
EUROPÄISCHES KOMITEE FÜR NORMUNG

Management Centre: rue de Stassart, 36 B-1050 Brussels

Contents		Page
Foreword		3
1	Scope	4
2	Normative references	4
3	Required characteristics	5
4	Designation	7
5	Marking	7
6	Technical specification.....	7

iTeh STANDARD PREVIEW
(standards.iteh.ai)

[SIST EN 2881:2009](https://standards.iteh.ai/catalog/standards/sist/d5fabd9d-ed1e-4c6e-9c96-1f7901ca3133/sist-en-2881-2009)

<https://standards.iteh.ai/catalog/standards/sist/d5fabd9d-ed1e-4c6e-9c96-1f7901ca3133/sist-en-2881-2009>

Foreword

This European Standard (EN 2881:2006) has been prepared by the European Association of Aerospace Manufacturers - Standardization (AECMA-STAN).

After enquiries and votes carried out in accordance with the rules of this Association, this Standard has received the approval of the National Associations and the Official Services of the member countries of AECMA, prior to its presentation to CEN.

This European Standard shall be given the status of a national standard, either by publication of an identical text or by endorsement, at the latest by November 2006, and conflicting national standards shall be withdrawn at the latest by November 2006.

Attention is drawn to the possibility that some of the elements of this document may be the subject of patent rights. CEN [and/or CENELEC] shall not be held responsible for identifying any or all such patent rights.

According to the CEN/CENELEC Internal Regulations, the national standards organizations of the following countries are bound to implement this European Standard: Austria, Belgium, Cyprus, Czech Republic, Denmark, Estonia, Finland, France, Germany, Greece, Hungary, Iceland, Ireland, Italy, Latvia, Lithuania, Luxembourg, Malta, Netherlands, Norway, Poland, Portugal, Romania, Slovakia, Slovenia, Spain, Sweden, Switzerland and the United Kingdom.

ITIH STANDARD PREVIEW
(standards.iteh.ai)

SIST EN 2881:2009

<https://standards.iteh.ai/catalog/standards/sist/d5fabd9d-ed1e-4c6e-9c96-1f7901ca3133/sist-en-2881-2009>

EN 2881:2006 (E)

1 Scope

This standard specifies the characteristics of self-locking, fuel resistant, sealing, floating, two lug anchor nuts, with counterbore, in corrosion resisting steel, passivated, MoS₂ lubricated, metric series.

Classification: 900 MPa ¹⁾ / 120 °C ²⁾

2 Normative references

The following referenced documents are indispensable for the application of this document. For dated references, only the edition cited applies. For undated references, the latest edition of the referenced document (including any amendments) applies.

ISO 5855-2, *Aerospace — MJ threads — Part 2: Limit dimensions for bolts and nuts.*

ISO 5858, *Aerospace — Nuts, self-locking, with maximum operating temperature less than or equal to 425 °C — Procurement specification.*

ISO 8788, *Aerospace — Nuts, metric — Tolerances of form and position.*

ISO 8940, *Aerospace — Nuts, anchor, self-locking, sealing, floating, two-lug, with counterbore, with MJ threads, classifications: 900 MPa (at ambient temperature)/120 °C, 900 MPa (at ambient temperature)/175 °C and 900 MPa (at ambient temperature)/235 °C — Dimensions.*

EN 2424, *Aerospace series — Marking of aerospace products.*

EN 2491, *Aerospace series — Molybdenum disulphide dry lubricants — Coating methods.*

EN 2516, *Aerospace series — Passivation of corrosion resisting steels and decontamination of nickel base alloys.*

EN 9100, *Aerospace series — Quality management systems — Requirements (based on ISO 9001:2000) and Quality systems — Model for quality assurance in design, development, production, installation and servicing (based on ISO 9001:1994).*

EN 9133, *Aerospace series — Quality management systems — Qualification Procedure for aerospace standard parts.*

MIL-R-6855E, *Rubber, synthetic, sheets, strips, molded or extruded shapes, general specification for.*³⁾

TR 3791, *Aerospace series — Materials for self-locking nuts, threaded inserts and screw thread inserts of temperature classes ≤ 425 °C.*⁴⁾

1) Corresponds to the minimum tensile stress which the nut is able to withstand at ambient temperature without breaking or cracking when tested with a bolt of a higher strength class.

2) Maximum temperature that the nut is able to withstand, without permanent alteration to its original characteristics, after ambient temperature has been restored. The maximum temperature is conditioned by the seal material.

3) Published by: Department of Defense (DoD), the Pentagon, Washington, D.C. 20301, USA.

4) Published as AECMA Technical Report at the date of publication of this standard.

3 Required characteristics

3.1 Configuration – Dimensions – Masses

See Figure 1 and Table 1.

Dimensions and tolerances are: in conformity with ISO 8940, expressed in millimetres and apply after surface treatment but before MoS₂ lubrication.

Details of form not stated are at the manufacturer's option.

3.2 Tolerances of form and position

See ISO 8788.

3.3 Materials

Cage, seal retainer and nut element: TR 3791

Sealing ring: rubber, fuel resistant per MIL-R-6855, class 1, grade 60 or equivalent.

3.4 Surface treatments

Cage and seal retainer: EN 2516

Nut element: EN 2491, thickness not specified, mandatory on threads, optional on other surfaces

SIST EN 2881:2009
<https://standards.iteh.ai/catalog/standards/sist/d5fabd9d-ed1e-4c6e-9c96-1f7901ca3133/sist-en-2881-2009>

EN 2881:2006 (E)

6,3 $\sqrt{\quad}$ $\left[\begin{array}{c} 3,2 \\ \sqrt{\quad} \end{array} \right]$ These values in micrometres apply before surface treatment. They do not apply to threads, punched holes or sheared edges the surface texture of which will be as achieved by usual manufacturing methods.

Remove sharp edges 0,1 to 0,4.

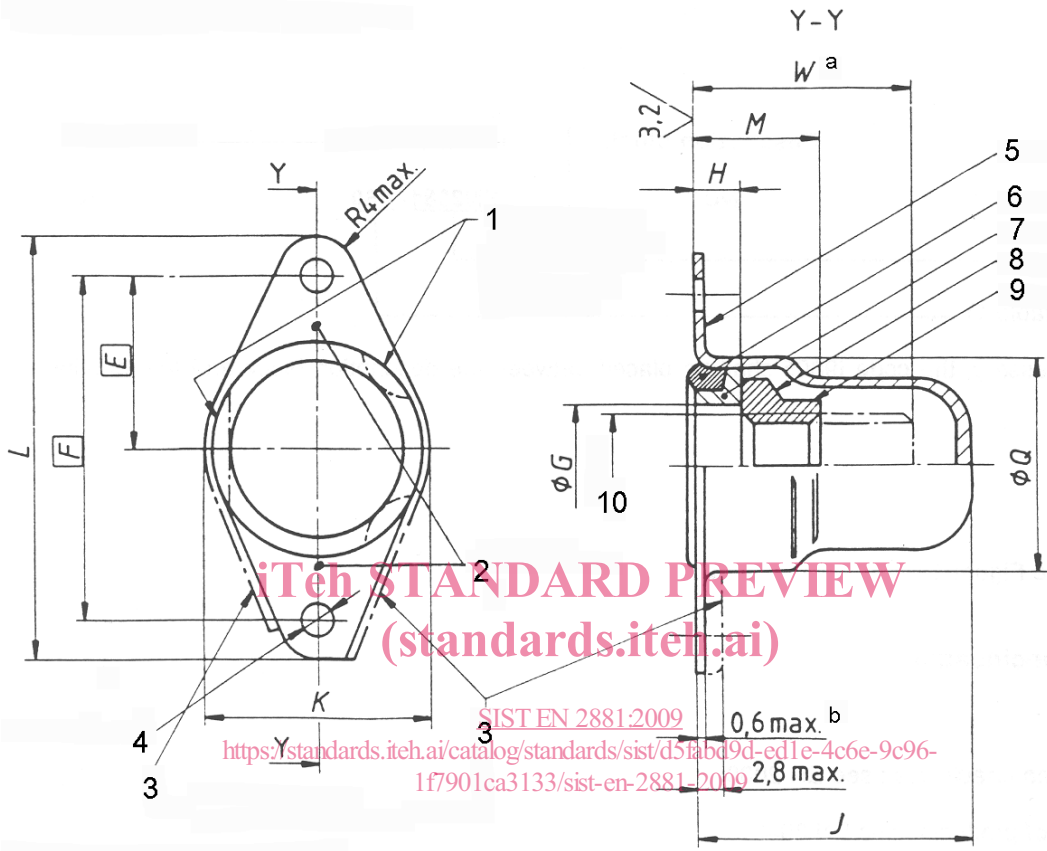

Key

- 1 Threaded element anti-rotational device (form at manufacturer's discretion)
 - 2 Marking
 - 3 Choice of flange at manufacturer's option
 - 4 Two holes $\varnothing S$
 - 5 Cage
 - 6 Seal
 - 7 Seal retainer
 - 8 Nut element. Minimum radial float of nut element: 0,5
 - 9 Form-out-round in this area to achieve the self-locking torque requirement (tooling marks permissible)
 - 10 Thread
- ^a Maximum bolt thread intrusion
^b Lug thickness at the rivet location

Figure 1