

ETSI EN 302 583 V1.1.1 (2008-03)

European Standard (Telecommunications series)

Digital Video Broadcasting (DVB); Framing Structure, channel coding and modulation for Satellite Services to Handheld devices (SH) below 3 GHz

European Broadcasting Union

Union Européenne de Radio-Télévision



*ITeH STANDARD PREVIEW
(standards.iteh.ai)*

*Full standard:
<https://standards.iteh.ai/catalog/standards/sist/6317e4-d317-4552-afe4-1a378e982e32/etsi-en-302-583-v1-1-2008-03>*



Reference

DEN/JTC-DVB-207

Keywords

broadcast, DVB

ETSI

650 Route des Lucioles
F-06921 Sophia Antipolis Cedex - FRANCE

Tel.: +33 4 92 94 42 00 Fax: +33 4 93 65 47 16

Siret N° 348 623 562 00017 - NAF 742 C
Association à but non lucratif enregistrée à la
Sous-Préfecture de Grasse (06) N° 7803/88

Important notice

Individual copies of the present document can be downloaded from:

<http://www.etsi.org>

The present document may be made available in more than one electronic version or in print. In any case of existing or perceived difference in contents between such versions, the reference version is the Portable Document Format (PDF). In case of dispute, the reference shall be the printing on ETSI printers of the PDF version kept on a specific network drive within ETSI Secretariat.

Users of the present document should be aware that the document may be subject to revision or change of status. Information on the current status of this and other ETSI documents is available at

<http://portal.etsi.org/tb/status/status.asp>

If you find errors in the present document, please send your comment to one of the following services:

http://portal.etsi.org/chaicor/ETSI_support.asp

Copyright Notification

No part may be reproduced except as authorized by written permission.
The copyright and the foregoing restriction extend to reproduction in all media.

© European Telecommunications Standards Institute 2008.

© European Broadcasting Union 2008.

All rights reserved.

DECT™, PLUGTESTS™, UMTS™, TIPHON™, the TIPHON logo and the ETSI logo are Trade Marks of ETSI registered for the benefit of its Members.

3GPP™ is a Trade Mark of ETSI registered for the benefit of its Members and of the 3GPP Organizational Partners.

Contents

Intellectual Property Rights	5
Foreword.....	5
1 Scope	6
2 References	6
2.1 Normative references	7
2.2 Informative references.....	7
3 Definitions, symbols and abbreviations	7
3.1 Definitions.....	7
3.2 Symbols.....	8
3.3 Abbreviations	8
4 Transmission system description.....	9
4.1 System definition.....	9
4.2 System architecture	9
5 Subsystems specification.....	10
5.1 Mode adaptation.....	10
5.1.1 CRC-16 encoder	11
5.1.2 Encapsulation Frame Header insertion	12
5.2 Stream adaptation	13
5.2.1 Padding	13
5.2.2 EScrambling	13
5.3 FEC encoding and channel interleaving.....	14
5.3.1 Constituent codes of the turbo encoder and puncturing patterns	14
5.3.2 Turbo code termination.....	16
5.3.3 Turbo interleavers.....	17
5.4 Channel interleaver and rate adaptation	19
5.4.1 Overview	19
5.4.2 Bit-wise interleaving and rate adaptation.....	19
5.4.3 Time interleaver.....	21
5.5 Frame structure.....	22
5.5.1 Interface with FEC encoding.....	22
5.5.2 SH Frame structure	22
5.5.2.1 Overview.....	22
5.5.2.2 Elementary parts description.....	25
5.5.2.3 OFDM mode	26
5.5.2.4 TDM mode.....	28
5.5.3 Interface with modulation.....	28
5.6 Single carrier (TDM).....	28
5.6.1 Interface to SH frame.....	28
5.6.2 Bit mapping into constellation.....	29
5.6.2.1 Bit mapping into QPSK constellation	29
5.6.2.2 Bit mapping into 8PSK constellation	30
5.6.2.3 Bit mapping into 16APSK constellation	30
5.6.3 TDM symbol rate selection.....	31
5.6.4 TDM framing.....	31
5.6.4.1 PL Slot definition	31
5.6.4.2 Pilot insertion	32
5.6.4.3 Physical layer scrambling	33
5.6.5 Baseband shaping and quadrature modulation.....	34
5.7 Multi carrier (OFDM)	35
5.7.1 Interface to SH frame.....	35
5.7.1.1 CU mapping	35
5.7.1.2 Bit demultiplexing.....	35
5.7.2 Symbol interleaver.....	36

5.7.3	Bit mapping into constellation	39
5.7.4	OFDM framing	41
5.7.4.1	OFDM frame structure	41
5.7.4.2	Reference signals	45
5.7.4.2.1	Functions and derivation	45
5.7.4.2.2	Definition of reference sequence	45
5.7.4.2.3	Location of scattered pilot cells	46
5.7.4.2.4	Location of continual pilot carriers	46
5.7.4.2.5	Amplitudes of all reference information	48
5.7.4.3	Transmission Parameter Signalling (TPS)	48
5.7.4.3.1	Scope of the TPS	49
5.7.4.3.2	TPS transmission format	49
5.7.4.3.3	TPS modulation	54
5.7.5	Baseband shaping and quadrature modulation	55
Annex A (normative): SH frame Initialization Packet (SHIP)		56
A.1	Introduction	56
A.2	SHIP header	56
A.3	Mandatory parameters	57
A.4	Optional SHIP section parameters	58
A.4.1	Transmitter time offset function	59
A.4.2	Transmitter frequency offset function	59
A.4.3	Transmitter power function	60
A.4.4	Private data function	60
A.4.5	Cell id function	60
A.4.6	Enable function	61
A.4.7	Bandwidth function	61
A.4.8	Service localization function	61
A.4.9	Service synchronization function	62
A.4.10	TDM function	63
A.4.11	Group membership function	64
A.5	CRC decoder model	65
Annex B (informative): Bibliography		67
History		68

Intellectual Property Rights

IPRs essential or potentially essential to the present document may have been declared to ETSI. The information pertaining to these essential IPRs, if any, is publicly available for **ETSI members and non-members**, and can be found in ETSI SR 000 314: "*Intellectual Property Rights (IPRs); Essential, or potentially Essential, IPRs notified to ETSI in respect of ETSI standards*", which is available from the ETSI Secretariat. Latest updates are available on the ETSI Web server (<http://webapp.etsi.org/IPR/home.asp>).

Pursuant to the ETSI IPR Policy, no investigation, including IPR searches, has been carried out by ETSI. No guarantee can be given as to the existence of other IPRs not referenced in ETSI SR 000 314 (or the updates on the ETSI Web server) which are, or may be, or may become, essential to the present document.

Foreword

This European Standard (Telecommunications series) has been produced by Joint Technical Committee (JTC) Broadcast of the European Broadcasting Union (EBU), Comité Européen de Normalisation ELECtrotechnique (CENELEC) and the European Telecommunications Standards Institute (ETSI).

The work of the JTC was based on the studies carried out by the European DVB Project under the auspices of the Ad Hoc Group on DVB-SH of the DVB Technical Module. This joint group of industry, operators and broadcasters provided the necessary information on all relevant technical matters (see bibliography).

NOTE: The EBU/ETSI JTC Broadcast was established in 1990 to co-ordinate the drafting of standards in the specific field of broadcasting and related fields. Since 1995 the JTC Broadcast became a tripartite body by including in the Memorandum of Understanding also CENELEC, which is responsible for the standardization of radio and television receivers. The EBU is a professional association of broadcasting organizations whose work includes the co-ordination of its members' activities in the technical, legal, programme-making and programme-exchange domains. The EBU has active members in about 60 countries in the European broadcasting area; its headquarters is in Geneva.

European Broadcasting Union
CH-1218 GRAND SACONNEX (Geneva)
Switzerland
Tel: +41 22 717 21 11
Fax: +41 22 717 24 81

Founded in September 1993, the DVB Project is a market-led consortium of public and private sector organizations in the television industry. Its aim is to establish the framework for the introduction of MPEG-2 based digital television services. Now comprising over 200 organizations from more than 25 countries around the world, DVB fosters market-led systems, which meet the real needs, and economic circumstances, of the consumer electronics and the broadcast industry.

National transposition dates

Date of adoption of this EN:	14 March 2008
Date of latest announcement of this EN (doa):	30 June 2008
Date of latest publication of new National Standard or endorsement of this EN (dop/e):	31 December 2008
Date of withdrawal of any conflicting National Standard (dow):	31 December 2008

1 Scope

The present document specifies a transmission system for hybrid satellite and terrestrial digital television broadcasting to mobile terminals. It is derived from the DVB-T [1] and DVB-H [6] system specification, respectively designed for digital television terrestrial broadcasting towards fixed and mobile terminals and DVB-S2, [2] designed for digital satellite broadcasting towards fixed terminals. The purpose of the DVB-SH standard is to provide an efficient transmission system using frequencies below 3 GHz suitable for Satellite Services to Handheld devices, in terms of reception threshold and resistance to mobile satellite channel impairments.

The system relies on a hybrid satellite/terrestrial infrastructure. The signals are broadcast to mobile terminals on two paths:

- A direct path from a broadcast station to the terminals via the satellite.
- An indirect path from a broadcast station to terminals via terrestrial repeaters that form the Complementary Ground Component (CGC) to the satellite. The CGC can be fed through satellite and/or terrestrial distribution networks.

The system includes two transmission modes:

- An OFDM mode based on DVB-T standard [1] with enhancements. This mode can be used on both the direct and indirect paths; the two signals are combined in the receiver to strengthen the reception in a SFN configuration.
- A TDM mode partly derived from DVB-S2 standard [2], in order to optimize transmission through satellite towards mobile terminals. This mode is used on the direct path only. The system supports code diversity recombination between satellite TDM and terrestrial OFDM modes so as to increase the robustness of the transmission in relevant areas (mainly suburban).

The present document specifies the digital signal format and the digital signal modulation and coding in order to allow compatibility between pieces of equipment developed by different manufacturers. Signal processing at the modulator side is described in details, while processing at receiver side is left open to a particular implementation (as far as it complies with the present document).

2 References

References are either specific (identified by date of publication and/or edition number or version number) or non-specific.

- For a specific reference, subsequent revisions do not apply.
- Non-specific reference may be made only to a complete document or a part thereof and only in the following cases:
 - if it is accepted that it will be possible to use all future changes of the referenced document for the purposes of the referring document;
 - for informative references.

Referenced documents which are not found to be publicly available in the expected location might be found at <http://docbox.etsi.org/Reference>.

For online referenced documents, information sufficient to identify and locate the source shall be provided. Preferably, the primary source of the referenced document should be cited, in order to ensure traceability. Furthermore, the reference should, as far as possible, remain valid for the expected life of the document. The reference shall include the method of access to the referenced document and the full network address, with the same punctuation and use of upper case and lower case letters.

NOTE: While any hyperlinks included in this clause were valid at the time of publication ETSI cannot guarantee their long term validity.

2.1 Normative references

The following referenced documents are indispensable for the application of the present document. For dated references, only the edition cited applies. For non-specific references, the latest edition of the referenced document (including any amendments) applies.

- [1] ETSI EN 300 744: "Digital Video Broadcasting (DVB); Framing structure, channel coding and modulation for digital terrestrial television".
- [2] ETSI EN 302 307: "Digital Video Broadcasting (DVB); Second generation framing structure, channel coding and modulation systems for Broadcasting, Interactive Services, News Gathering and other broadband satellite applications".
- [3] 3GPP2 C.S0002-D, September 2005: "3GPP2: Physical Layer Standard for cdma2000 Spread Spectrum Systems, Revision D".

NOTE: See http://www.3gpp2.org/Public_html/specs/C.S0002-D_v2.0_051006.pdf.

- [4] ISO/IEC 13818-1: "Information technology - Generic coding of moving pictures and associated audio information: Systems".
- [5] ETSI EN 301 192: "Digital Video Broadcasting (DVB); DVB specification for data broadcasting".
- [6] ETSI EN 302 304: "Digital Video Broadcasting (DVB); Transmission System for Handheld Terminals (DVB-H)".
- [7] ETSI TS 102 606: "Digital Video Broadcasting (DVB); Generic Stream Encapsulation (GSE) Protocol".
- [8] Void.
- [9] ETSI TS 102 585: "Digital Video Broadcasting (DVB); System Specifications for Satellite services to Handheld devices (SH) below 3 GHz".
- [10] ETSI EN 300 468: "Digital Video Broadcasting (DVB); Specification for Service Information (SI) in DVB systems".

2.2 Informative references

Not applicable.

3 Definitions, symbols and abbreviations

3.1 Definitions

For the purposes of the present document, the following terms and definitions apply:

class 1 receiver: support short physical layer protection in the order of one DVB-H burst

NOTE: As defined in [9].

class 2 receivers: support long physical layer protection in the order of several DVB-H bursts

NOTE: As defined in [9].

code combining: transmission and decoding technique consisting in transmitting complementary or partially complementary components of a mother code through different channels (in SH-B systems, using satellite TDM and terrestrial OFDM) and recombining the punctured parts into a single coded FEC block before decoding

SH-A architecture: DVB-SH system using OFDM on the satellite path

NOTE: As defined in [9].

SH-B architecture: DVB-SH system using TDM on the satellite path

NOTE: As defined in [9].

3.2 Symbols

For the purposes of the present document, the following symbols apply:

$L_{TC-input}$	Turbo Code input block length in bits
q'	Symbol Number

3.3 Abbreviations

For the purposes of the present document, the following abbreviations apply:

BCH	Bose, Ray-Chaudhuri, Hocquenghem
CGC	Complementary Ground Component
CR	Code Rate
CRC	Cyclic Redundancy Check
CU	Capacity Unit

NOTE: Defined as a block of 2 016 bits.

D	Decimal notation
DFL	DATAFIELD Length
DVB	Digital Video Broadcasting project
DVB-H	Digital Video Broadcasting for Handheld terminals
DVB-S	Digital Video Broadcasting for Satellite services
DVB-S2	DVB-S, second generation
DVB-T	Digital Video Broadcasting for Terrestrial services
EBU	European Broadcasting Union
EFRAME	Encapsulation Frame
EHEADER	Encapsulation Frame Header
EN	European Norm
EXOR	Exclusive OR function
FEC	Forward Error Correction
FFT	Fast Fourier Transform
FIFO	First In First Out
GF	Galois Field
ISI	Input Stream Identifier
IU	Interleaver Unit

NOTE: Defined as a set of 126 bits.

LSB	Least Significant Bit
MIP	Mega-frame Initialization Packet
MPE	Multi-Protocol Encapsulation
MPEG	Moving Pictures Experts Group
MPEG-TS	MPEG-Transport Stream
MSB	Most Significant Bit
N_{BIL}	Number of bits at the output of the bit interleaver
NCW	Number of Coded words
N_{TCB}	Number of bits of the FEC (turbo) coded block
OFDM	Orthogonal Frequency Division Multiplexing
PER	(MPEG TS) Packet Error Rate
PID	Packet IDentifier
PL	Physical Layer

PRBS	Pseudo Random Binary Sequence
PSK	Phase Shift Keying
QAM	Quadrature Amplitude Modulation
QPSK	Quaternary Phase Shift Keying
RF	Radio Frequency
RFU	Reserved for Future Use
RSC	Recursive Systematic Convolutional Coder
SF	Signalling Field (inserted in TDM mode)
SFN	Single Frequency Network
SH	Satellite to Handheld
SHIP	SH frame Initialization Packet
SHL	SH frame Length (variable in TDM mode)
SL	Service Layer
SOF	Start Of Frame (inserted in TDM mode)
SYNC	User packet SYNChronization byte

EXAMPLE: 0x47 for MPEG packets.

TDM	Time Division Multiplex
TS	Transport Stream
UP	User Packet
UPL	User Packet Length

4 Transmission system description

4.1 System definition

The system is mainly designed to transport mobile TV services. It may also support a wide range of mobile multimedia services, e.g. audio and data broadcast as well as file download services.

The system performs the adaptation and transmission of one or two (in case of hierarchical mode) baseband signals to both satellite and terrestrial channel characteristics. Baseband signals at system input are, by default, MPEG Transport Streams (MPEG-TS, see [4]) and are composed of bursts compliant with DVB-H time slicing [5]. Typically a burst transports a given service (or set of services), e.g. a TV channel. The size of each burst may vary with time in order to support Variable burst Bit Rate.

The present document applies to the MPEG-TS format but the support of a Generic Stream is not precluded (see clause 5.1).

4.2 System architecture

Figure 4.1 describes the transmission system. It includes two modulation possibilities for the satellite path: an OFDM mode based on DVB-T standard and a TDM mode, partly derived from DVB-S2 structure.

The following process, composed of a part common to both modes, and parts dedicated to each mode, shall be applied to the input stream(s):

Both modes:

- Mode adaptation: CRC-16 and insertion of the Encapsulation Frame Header.
- Stream adaptation: padding and scrambling of the Encapsulation Frame.
- Forward Error Correction (FEC) encoding using 3GPP2 [3] turbo code.
- Bit-wise interleaving applying on a FEC block. The latter is meanwhile shortened to comply with the modulation frame structure of OFDM and TDM.
- Convolutional time interleaving and framing.

TDM mode:

- Bit mapping to the constellation.
- TDM physical layer framing.
- Pilots insertion and scrambling.
- Pulse shaping and quadrature modulation.

OFDM mode:

- Symbol interleaver.
- Bit mapping to the constellation.
- OFDM framing with pilots and TPS insertion.

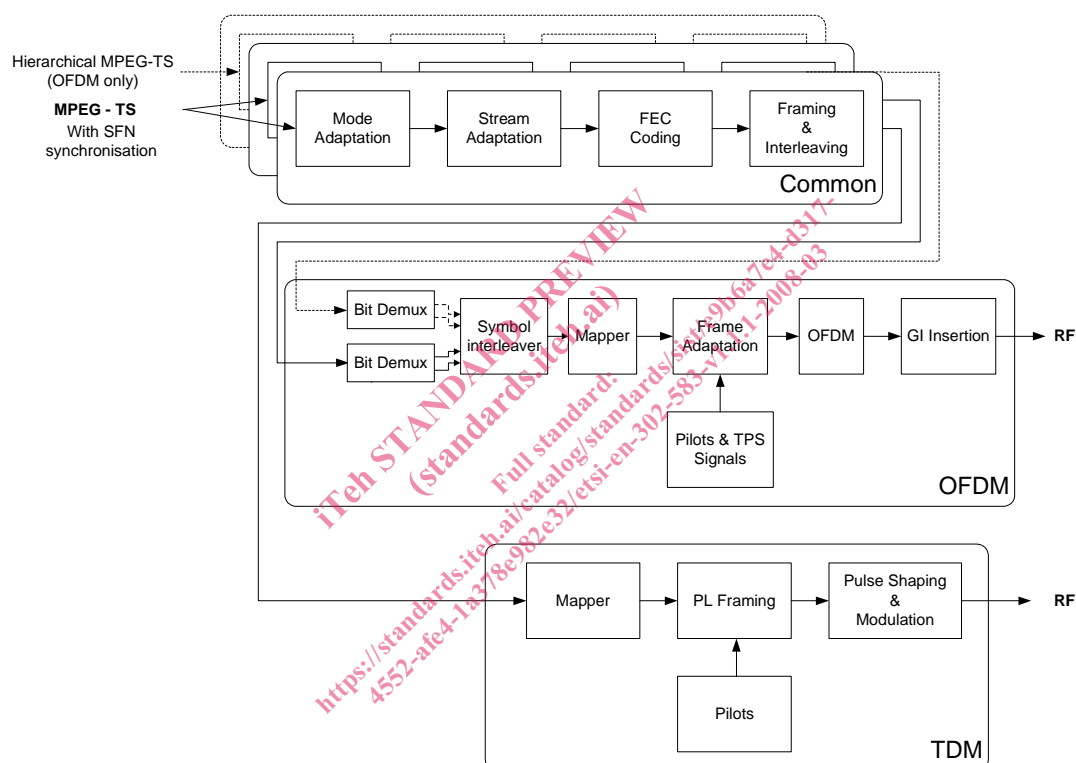

Figure 4.1: Functional block diagram of the DVB-SH transmitter (Either TDM or OFDM configurations)

5 Subsystems specification

5.1 Mode adaptation

Figure 5.1 gives the functional block diagram of the mode adaptation. It consists of CRC encoding, to provide error detection on every MPEG packet, and of inserting an Encapsulation Signalling (ESignalling). Even if the current version of the air interface fully supports only MPEG-TS input stream, mode adaptation is already able to handle any input stream format, be it packetized or not. The ESignalling process (thanks to the EHEADER structure, see clause 5.1.2) straightforwardly ensures this full compliance.

The output of mode adaptation is composed of an EHEADER followed by a DATAFIELD.

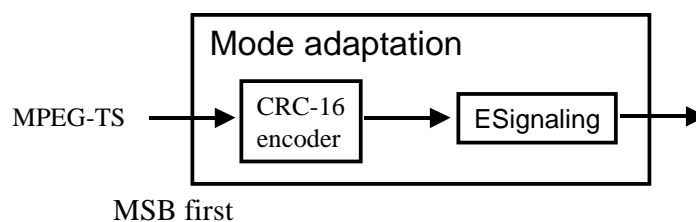

Figure 5.1: Functional block diagram of the mode adaptation

An MPEG Transport Stream corresponds to User Packets (UP) of constant length $UPL = 188 \times 8_D$ bits (one MPEG packet), the first byte being a Sync-Byte (47HEX). A DATAFIELD is designed so as to contain exactly 8 MPEG packets.

The DATAFIELD has an index related to the SH Frame.

5.1.1 CRC-16 encoder

CRC-16 encoding provides error detection capability to upper layers. The input stream is a sequence of User Packets of length UPL bits ($UPL = 188$ bytes), starting with a Sync-Byte.

The useful part of the UP (excluding the Sync-Byte) shall be processed by a systematic 16-bit CRC encoder. The generator polynomial shall be $0x1021$:

$$g(X) = X^{16} + X^{12} + X^5 + 1$$

The CRC encoder output shall be computed as:

$$\text{CRC} = \text{remainder}[X^{16} u(X) : g(X)]$$

with $u(X)$ being the input sequence ($UPL - 8$ bits) to be systematically encoded. The generator $g(X)$ shall be initialized with the sequence $0xFFFF$. The computed CRC-16 shall be placed at the end of the current User Packet, and the SYNC-Byte shall be removed, as shown on figure 5.2. As described in clause 5.1.2, the Sync-Byte is copied into the SYNC field of the EHEADER for transmission.

The DATAFIELD is composed of a set of 8 UPs with their CRC-16.

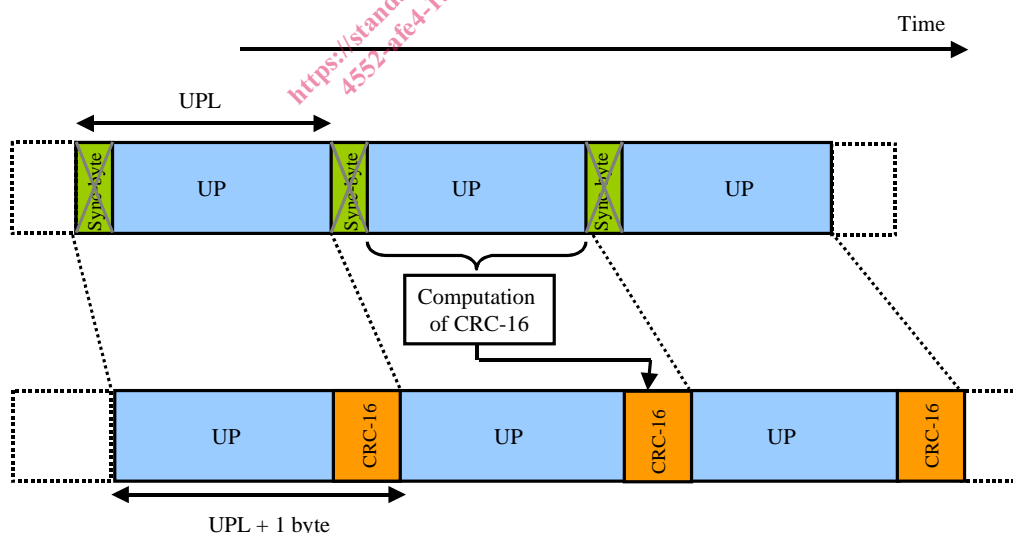

Figure 5.2: Illustration of the CRC-16 encoding process

5.1.2 Encapsulation Frame Header insertion

A fixed length Encapsulation Frame Header (EHEADER) of 114 bits shall be inserted in front of the DATAFIELD (see figure 5.3). The EHEADER aims at signalling the input stream features and supporting the code diversity. First field of EHEADER is devoted to support other input stream formats than MPEG-TS. Value 01 is devoted to a data stream encapsulated according to Generic Stream Encapsulation protocol as defined in [7]. The format of the EHEADER is the following (see also figure 5.3):

- TIS (2 bits): Type of Input Stream according to table 5.1.

Table 5.1: TIS mapping field

TIS	Description
11	[MPEG-TS]
10	[reserved]
01	[Generic Stream]
00	[reserved]

- UPL (16 bits): User Packet length in bits.
 - $UPL = 188 \times 8_D$ for MPEG-TS.
- DFL (16 bits): DATAFIELD Length in bits.
 - DFL = 12 096 bits for MPEG-TS.
- SYNC (8 bits): copy of the User Packet Sync-Byte (identical for all packets).
- RFU (32 bits): to support future additional features.
- CBCOUNTER (24 bits): this field identifies the FEC block position index, hence enabling supports of code diversity through tagging of each EFRAME/FEC codeword. It is split into two parts:
 - CBCOUNTER_SH (msb 14 bits): two cases are possible depending on the SHIP service synchronization function (please refer to clause A.4.9):
 - If service synchronization is not present on this transmitter, all bits are set to 0.
 - If service synchronization is present on this transmitter, it indicates the number of the SH frame inside the frame multiplexing (first SH frame), it is incremented by 1 every SH frame that has no start of service 0, it is reset to 0 at each SH frame having a service 0 start.
 - CBCOUNTER_FB (lsb 10 bits):
 - Indicates position index of the EFRAME/FEC block inside current SH frame, first position being coded as 0 (zero).
 - Incremented by 1 every EFRAME.
 - Reset to 0 at each SH frame start.
- CRC-16 (16 bits): error detection code applied to the first 98 bits of the EHEADER. CRC-16 shall be computed using the same way as defined in clause 5.1.1.

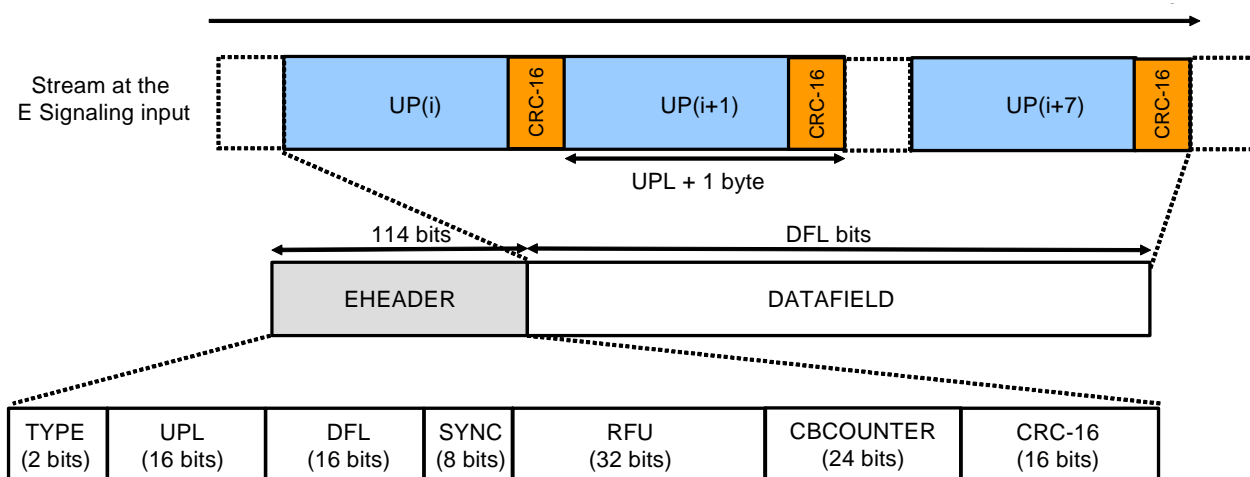

Figure 5.3: Description of the ESignalling process

5.2 Stream adaptation

Stream adaptation (see figures 5.4 and 5.5) provides padding to complete a constant length ($L_{TC-input} = 12\ 282$ bits) Encapsulation Frame (EFRAME) and performs scrambling. EFRAME is designed so as to match the input turbo code block size, namely $L_{TC-input} = 12\ 282$ bits, independently of the code rate.

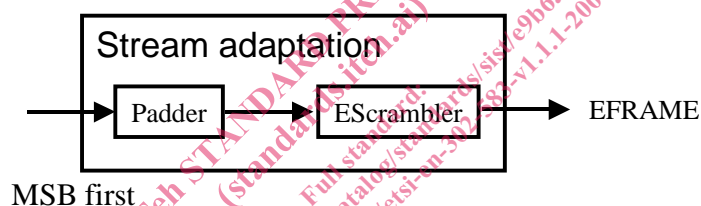

Figure 5.4: Functional block diagram of the stream adaptation

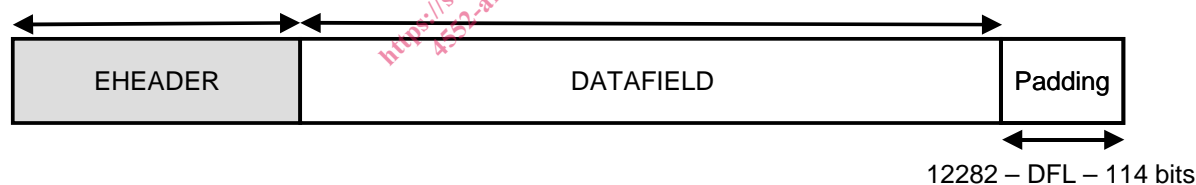

Figure 5.5: EFRAME format at the output of stream adaptation

5.2.1 Padding

In DVB-SH system, $(12\ 282 - DFL - 114)$ bits of zero bits shall be appended after the DATAFIELD. The resulting EFRAME shall have a constant length of $L_{TC-input}$ bits, namely $12\ 282$ bits.

For MPEG-TS, $DFL = 8 \times (187 + 2) \times 8 = 12\ 096$ bits. Therefore 72 bits (9 bytes) of padding are required.

5.2.2 EScrambling

The complete EFRAME shall be randomized. The randomization sequence shall be synchronous with the EFRAME, starting from the MSB and ending after $L_{TC-input}$ bits.