**Dental hand instruments — Reusable
mirrors and handles**

Instruments dentaires à main — Miroirs et manches de miroirs réutilisables

iTeh STANDARD PREVIEW
(standards.iteh.ai)

[ISO 9873:1998](https://standards.iteh.ai/catalog/standards/sist/60888ee1-8f66-4b47-a0c3-c165a7d947a2/iso-9873-1998)

<https://standards.iteh.ai/catalog/standards/sist/60888ee1-8f66-4b47-a0c3-c165a7d947a2/iso-9873-1998>



Contents	Page
1 Scope	1
2 Normative references	1
3 Definitions	1
4 Requirements	2
5 Test methods.....	5
6 Marking	9
Annex A Bibliography	10

iTeh STANDARD PREVIEW
(standards.iteh.ai)

ISO 9873:1998

<https://standards.iteh.ai/catalog/standards/sist/60888ee1-8f66-4b47-a0c3-c165a7d947a2/iso-9873-1998>

© ISO 1998

All rights reserved. Unless otherwise specified, no part of this publication may be reproduced or utilized in any form or by any means, electronic or mechanical, including photocopying and microfilm, without permission in writing from the publisher.

International Organization for Standardization
Case postale 56 • CH-1211 Genève 20 • Switzerland
Internet iso@iso.ch

Printed in Switzerland

Foreword

ISO (the International Organization for Standardization) is a worldwide federation of national standards bodies (ISO member bodies). The work of preparing International Standards is normally carried out through ISO technical committees. Each member body interested in a subject for which a technical committee has been established has the right to be represented on that committee. International organizations, governmental and non-governmental, in liaison with ISO, also take part in the work. ISO collaborates closely with the International Electrotechnical Commission (IEC) on all matters of electrotechnical standardization.

Draft International Standards adopted by the technical committees are circulated to the member bodies for voting. Publication as an International Standard requires approval by at least 75 % of the member bodies casting a vote.

International Standard ISO 9873 was prepared by Technical Committee ISO/TC 106, *Dentistry*, Subcommittee 4, *Dental instruments*.

This second edition cancels and replaces the first edition (ISO 9873:1990), of which it constitutes a technical revision.

Annex A of this International Standard is for information only.

iTeh STANDARD PREVIEW (standards.iteh.ai)

[ISO 9873:1998](https://standards.iteh.ai/catalog/standards/sist/60888ee1-8f66-4b47-a0c3-c165a7d947a2/iso-9873-1998)

<https://standards.iteh.ai/catalog/standards/sist/60888ee1-8f66-4b47-a0c3-c165a7d947a2/iso-9873-1998>

Introduction

This International Standard specifies requirements for a type of dental viewing and retracting instrument in common use throughout the world. However, it is well known that there are also other types of mirrors in use which have different designs and/or are made of different materials. Amongst these other types are mirrors with plastics cases and/or stems; mirrors with a polished metal reflecting surface (as opposed to a coated glass surface); mirrors with a cone socket design; and single-use mirrors. Standardization of these other types may form the subject of future work.

iTeh STANDARD PREVIEW (standards.iteh.ai)

[ISO 9873:1998](https://standards.iteh.ai/catalog/standards/sist/60888ee1-8f66-4b47-a0c3-c165a7d947a2/iso-9873-1998)

<https://standards.iteh.ai/catalog/standards/sist/60888ee1-8f66-4b47-a0c3-c165a7d947a2/iso-9873-1998>

Dental hand instruments — Reusable mirrors and handles

1 Scope

This International Standard specifies requirements and test methods for reusable mouth mirrors with a coated glass reflecting surface and metal casing and metallic handles suitable for dental use in the oral cavity.

2 Normative references

The following standards contain provisions which, through reference in this text, constitute provisions of this International Standard. At the time of publication, the editions indicated were valid. All standards are subject to revision, and parties to agreements based on this International Standard are encouraged to investigate the possibility of applying the most recent editions of the standards indicated below. Members of IEC and ISO maintain registers of currently valid International Standards.

ISO 68-1:—¹⁾, *ISO general-purpose screw threads — Basic profile — Part 1: Metric screw threads.*

ISO 724:1993, *ISO general-purpose metric screw threads — Basic dimensions.*

ISO 965-1:—²⁾, *ISO general-purpose metric screw threads — Tolerances — Part 1: Principles and basic data.*

ISO 1942-3:1989, *Dental vocabulary — Part 3: Dental instruments.*

ISO 3696:1987, *Water for analytical laboratory use — Specification and test methods.*

ISO 7153-1:1991, *Surgical instruments — Metallic materials — Part 1: Stainless steel.*

ISO 13402:1995, *Surgical and dental hand instruments — Determination of resistance against autoclaving, corrosion and thermal exposure.*

3 Definitions

For the purposes of this International Standard, the definitions in ISO 1942-3 and the following definitions apply.

3.1

mirror

intra-oral inspection or inspection and retraction instrument generally comprising the mirror head and the mirror handle

3.2

mirror head

assembly comprising a glass reflective surface, casing, packing (if present) and stem

—227—

1) To be published. (Revision in part of ISO 68:1973)

2) To be published. (Revision of ISO 965-1:1980)

**3.3
stem**

that part of the mirror head connecting the glass and casing to the handle

**3.4
reflecting surface**

layer applied to the mirror glass for the purpose of reflecting light

**3.5
reflecting back surface**

reflecting layer coated onto the back surface of the mirror glass so that the image can be observed through the glass

**3.6
reflecting front surface**

reflecting layer coated onto the front surface of the mirror glass so that the image can be observed with no intervening glass layer

**3.7
plane mirror**

dental mirror whose reflective surface is flat

**3.8
magnifying mirror**

dental mirror whose reflective surface is concave to produce an enlarged image of the object observed

**3.9
viewing surface**

surface of the mirror glass, excluding the bevel, not enclosed by the metal casing

See figure 1, diameter d_2 .

ISO 9873:1998

<https://standards.iteh.ai/catalog/standards/sist/60888ee1-8f66-4b47-a0c3-c165a7d947a2/iso-9873-1998>

**3.10
distortion**

image deformation due to optical defect(s)

4 Requirements

4.1 Dimensions

4.1.1 Overall length

The maximum overall length of mirror head plus handle shall be 178 mm. If the mirror can be separated from the handle for sterilization, the maximum overall length of 178 mm is applicable to each of the separate parts.

4.1.2 Dimensions of connection between stem and handle

The dimensions of the connection between stem and handle shall be M 2,5 in accordance with ISO 724. The tolerances for the stem shall be 6e and for the handle 6H, in accordance with ISO 965-1. The length of the thread engagement shall be as shown in figure 1.

4.1.3 Dimensions of mirror casing and viewing surface

Dental mirrors shall meet the dimensions given in figure 1 and table 1.

Table 1 — Mirror head and viewing surface

Preferred sizes and designation: nominal diameter d_1	d_2	Size designation currently in use
16	$d_1 - 2,5 \text{ mm max.}$	1
18		2
20		3
22		4
24		5
26	$d_1 - 3 \text{ mm max.}$	6
28		7
30		8

NOTE 1 The mirror head size designations are based on the nominal diameter d_1 of the casing, expressed in millimetres, each subsequent size increasing by 2 mm.

NOTE 2 The preferred sizes are recommended for designations for all dental applications.

iTeh STANDARD PREVIEW
(standards.iteh.ai)

Dimensions in millimetres

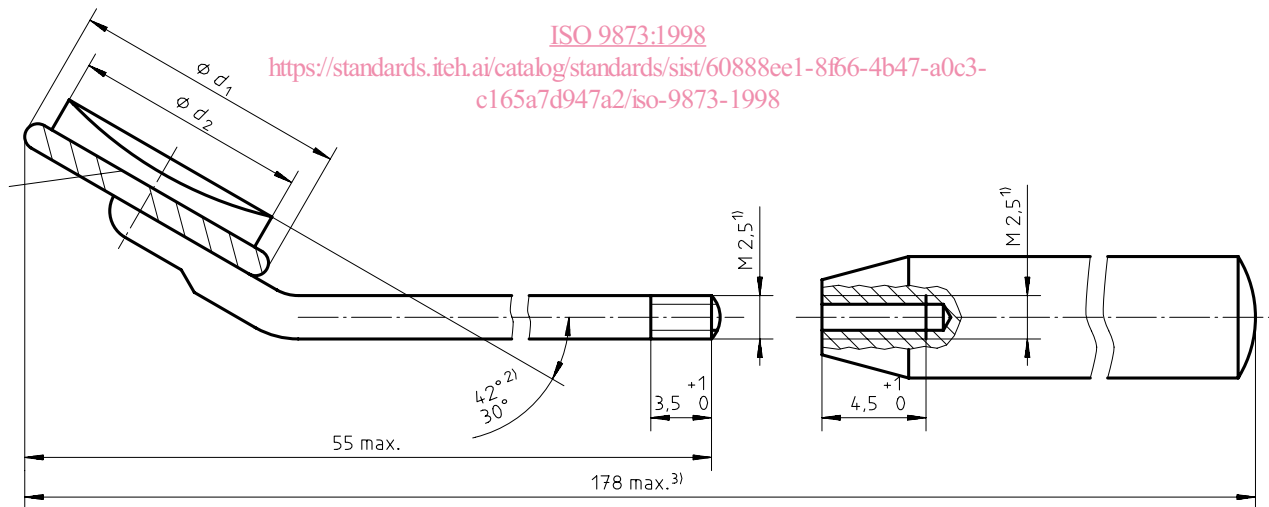

- 1) See ISO 724.
- 2) To be stated: see 6.3.
- 3) When assembled.

Figure 1 — Dental mirror

4.1.4 Position of mirror head with respect to stem

The mirror head shall be positioned such that the long axis of the stem bisects the casing to provide a symmetrical mount about the plane surface of the mirror glass/casing. Test in accordance with 5.1.

4.2 Material

4.2.1 Mirror glass

The mirror glass shall be made of polished glass free from visible defects such as waves, chips, scratches and other imperfections observable to the naked eye. Test in accordance with 5.1.

The glass or front-surface reflective coating shall show no blemish or other deterioration after having been tested. Test in accordance with 5.2, 5.3, 5.4 and 5.5.

4.2.2 Mirror casing

The mirror casing shall be made of a metal which is resistant to corrosion, e.g. stainless steel or a plated non-ferrous alloy. The metal shall show no visible signs of corrosion after having been tested. Any visible blemish on the metal shall be considered as evidence of corrosion. Test in accordance with 5.2, 5.3, 5.4 and 5.5.

4.2.3 Mirror handle

Mirror handles shall be made of stainless steel in accordance with ISO 7153-1; chromium-plated nonferrous metal or other metallic materials providing the handle made therefrom shall meet the requirements of 4.3.6.

4.3 Other requirements

iTeh STANDARD PREVIEW
(standards.iteh.ai)

4.3.1 Casing of mirror head

The casing shall have a formed edge which shall be below the level of the viewing surface of the glass and shall be visibly free from sharp edges, burs or other irregularities. Test in accordance with 5.1.

The glass shall be held and supported in position in the casing so that no movement can occur under normal conditions of use. The reflecting surface, and if applicable the packaging material within the mirror-head casing, shall show no sign of deterioration after having been tested. Test in accordance with 5.2.

4.3.2 Reflecting surfaces

The reflecting surfaces shall allow the image to be viewed through, or from, the whole of the viewing surface. Test in accordance with 5.1.

4.3.3 Nominal magnification

The nominal magnification of magnifying mirrors shall be between 2,8 and 3,3.

Nominal magnification, M , is calculated as

$$M = \frac{250}{f}$$

where

f is the focal length, in millimetres;

250 is the least distance of distinct vision, in millimetres.

Test in accordance with 5.6.2.

4.3.4 Distortion

There shall be no observable distortion when the reflecting surface of the plane or magnifying mirror is tested. Test in accordance with 5.7.

4.3.5 Casing/stem joint strength

The mirror casing/stem joint shall withstand the test load without observable loosening or distortion. Test in accordance with 5.8.

4.3.6 Handle

All external surfaces of the handle shall be visibly free from imperfections. Test in accordance with 5.1

The handle shall show no sign of deterioration, degradation or corrosion after having been tested. Test in accordance with 5.4 and 5.5 and inspect in accordance with 5.1.

Hollow handles shall emit no bubbles when tested. Test in accordance with 5.9 and inspect in accordance with 5.1.

5 Test methods

5.1 Visual inspection

Conduct visual inspection at normal visual acuity without magnification.

5.2 Test sequence

Carry out the procedures described in 5.3, 5.4 and 5.5 consecutively in one continuous operation as follows:

- 50 cycles for the mirror head according to the test specified in 5.3;
- five cycles for the complete instrument (mirror head with mirror handle) according to the autoclave test specified in 5.4;
- five cycles for the complete instrument (mirror head with mirror handle) according to the dry heat test specified in 5.5.

After completing the procedures described in 5.3, 5.4 and 5.5, wipe the instrument and vigorously rub it with a soft dry cloth. Inspect for any sign of corrosion or other deterioration in accordance with 5.1

5.3 Water and dry heat test

5.3.1 Materials

Distilled or deionized water of grade 3 according to ISO 3696.

5.3.2 Apparatus

5.3.2.1 Tank, made of corrosion-resistant material (i.e. stainless steel or chromium-plated base metal).

5.3.2.2 Dry heat oven, capable of being operated at (175 ± 5) °C.

5.3.3 Test procedure

Place the mirror head in distilled or deionized water (5.3.1) at room temperature and leave it there for 10 min. Remove the mirror head from the liquid and place in the dry heat oven (5.3.2.2) at (175 ± 5) °C and leave it there for 15 min.