



SLOVENSKI STANDARD SIST EN 4008-011:2009

01-julij-2009

5 YfcbUj h_U!`9`Ya Ybh`YY_fj b]]b`cdh] b] `dcj YnUj `!`CfcX`Y`nU`ghg_Ub`Y]b
df]dUXUc UcdfYa U!`\$%`XY. `Dcn]Wcb]fbU`bUdfUj UnU`_Yy`YA &&) &\$#&`\$%!
GHubXUfX`nUdfc]nj cX

Aerospace series - Elements of electrical and optical connection - Crimping tools and associated accessories - Part 011: Positioner for crimping tool M22520/2-01 - Product standard

STANDARD PREVIEW

Luft- und Raumfahrt - Elektrische und optische Verbindungselemente - Crimpwerkzeug und zugehöriges Zubehör - Teil 011: Positionierer für Crimpzange M22520/2-01 - Produktnorm

[SIST EN 4008-011:2009](https://standards.itih.ai/catalog/standards/sist/21505e68-cc55-40af-897e-920000000000/sist-en-4008-011-2009)

[https://standards.itih.ai/catalog/standards/sist/21505e68-cc55-40af-897e-](https://standards.itih.ai/catalog/standards/sist/21505e68-cc55-40af-897e-920000000000/sist-en-4008-011-2009)

Série aérospatiale - Organes de connexion électrique et optique - Outils de sertissage et accessoires associés - Partie 011 : Positionneur pour pince à sertir M22520/2-01 - Norme de produit

Ta slovenski standard je istoveten z: EN 4008-011:2006

ICS:

49.060 Š^cp \ aš Á^• [|b \ æ Aerospace electric
^|\ dã } aš] !^ { aš Á ã c { ã equipment and systems

SIST EN 4008-011:2009

en,de

iTeh STANDARD PREVIEW
(standards.iteh.ai)

[SIST EN 4008-011:2009](#)

<https://standards.iteh.ai/catalog/standards/sist/21505e68-ec55-40af-897e-9ee792b024f9/sist-en-4008-011-2009>

EUROPEAN STANDARD
NORME EUROPÉENNE
EUROPÄISCHE NORM

EN 4008-011

July 2006

ICS 49.060

English Version

**Aerospace series - Elements of electrical and optical connection
- Crimping tools and associated accessories - Part 011:
Positioner for crimping tool M22520/2-01 - Product standard**

Série aérospatiale - Organes de connexion électrique et
optique - Outils de sertissage et accessoires associés -
Partie 011 : Positionneur pour pince à sertir M22520/2-01 -
Norme de produit

Luft- und Raumfahrt - Elektrische und optische
Verbindungselemente - Crimpwerkzeug und zugehöriges
Zubehör - Teil 011: Positionierer für Crimpzange M22520/2-
01 - Produktnorm

This European Standard was approved by CEN on 6 February 2006.

CEN members are bound to comply with the CEN/CENELEC Internal Regulations which stipulate the conditions for giving this European Standard the status of a national standard without any alteration. Up-to-date lists and bibliographical references concerning such national standards may be obtained on application to the Central Secretariat or to any CEN member.

This European Standard exists in three official versions (English, French, German). A version in any other language made by translation under the responsibility of a CEN member into its own language and notified to the Central Secretariat has the same status as the official versions.

CEN members are the national standards bodies of Austria, Belgium, Cyprus, Czech Republic, Denmark, Estonia, Finland, France, Germany, Greece, Hungary, Iceland, Ireland, Italy, Latvia, Lithuania, Luxembourg, Malta, Netherlands, Norway, Poland, Portugal, Romania, Slovakia, Slovenia, Spain, Sweden, Switzerland and United Kingdom.



EUROPEAN COMMITTEE FOR STANDARDIZATION
COMITÉ EUROPÉEN DE NORMALISATION
EUROPÄISCHES KOMITEE FÜR NORMUNG

Management Centre: rue de Stassart, 36 B-1050 Brussels

Contents		Page
Foreword.....		3
1	Scope	4
2	Normative references	4
3	Terminology	4
4	Required characteristics	4
4.1	Description	4
4.2	Dimensions, mass	4
4.3	Material, surface treatment	6
5	Designation	6
6	Marking	6
7	Technical specification	6

iTeh STANDARD PREVIEW
(standards.iteh.ai)

[SIST EN 4008-011:2009](https://standards.iteh.ai/catalog/standards/sist/21505e68-ec55-40af-897e-9ee792b024f9/sist-en-4008-011-2009)

<https://standards.iteh.ai/catalog/standards/sist/21505e68-ec55-40af-897e-9ee792b024f9/sist-en-4008-011-2009>

Foreword

This European Standard (EN 4008-011:2006) has been prepared by the AeroSpace and Defense Industries Association of Europe - Standardization (ASD-STAN).

After enquiries and votes carried out in accordance with the rules of this Association, this Standard has received the approval of the National Associations and the Official Services of the member countries of ASD, prior to its presentation to CEN.

This European Standard shall be given the status of a national standard, either by publication of an identical text or by endorsement, at the latest by January 2007, and conflicting national standards shall be withdrawn at the latest by January 2007.

Attention is drawn to the possibility that some of the elements of this document may be the subject of patent rights. CEN [and/or CENELEC] shall not be held responsible for identifying any or all such patent rights.

According to the CEN/CENELEC Internal Regulations, the national standards organizations of the following countries are bound to implement this European Standard: Austria, Belgium, Cyprus, Czech Republic, Denmark, Estonia, Finland, France, Germany, Greece, Hungary, Iceland, Ireland, Italy, Latvia, Lithuania, Luxembourg, Malta, Netherlands, Norway, Poland, Portugal, Romania, Slovakia, Slovenia, Spain, Sweden, Switzerland and the United Kingdom.

ITeH STANDARD PREVIEW
(standards.iteh.ai)

[SIST EN 4008-011:2009](https://standards.iteh.ai/catalog/standards/sist/21505e68-ec55-40af-897e-9ee792b024f9/sist-en-4008-011-2009)

<https://standards.iteh.ai/catalog/standards/sist/21505e68-ec55-40af-897e-9ee792b024f9/sist-en-4008-011-2009>

EN 4008-011:2006 (E)**1 Scope**

This standard specifies the characteristics for the positioner used with the M22520/2-01 crimping tool to crimp electrical contact EN 3155-022 according to EN 4008-002.

2 Normative references

The following referenced documents are indispensable for the application of this document. For dated references, only the edition cited applies. For undated references, the latest edition of the referenced document (including any amendments) applies.

EN 2591-100, *Aerospace series — Elements of electrical and optical connection — Test methods — Part 100: General*

EN 3155-022, *Aerospace series — Electrical contacts used in elements of connection — Part 022: Contacts, electrical rectangular, male, type A, crimp, class R — Product standard*

EN 4008-001, *Aerospace series — Elements of electrical and optical connection — Crimping tools and associated accessories — Part 001: Technical specification*

EN 4008-002, *Aerospace series — Elements of electrical and optical connection — Crimping tools and associated accessories — Part 002: List of product standards*

MIL DTL-22520/2-01, *Crimping tools, terminal, hand, wire termination for wire barrel sizes 20 through 26*¹⁾

3 Terminology

See EN 2591-100.

[SIST EN 4008-011:2009
https://standards.iteh.ai/catalog/standards/sist/21505e68-ec55-40af-897e-9ee792b024f9/sist-en-4008-011-2009](https://standards.iteh.ai/catalog/standards/sist/21505e68-ec55-40af-897e-9ee792b024f9/sist-en-4008-011-2009)

4 Required characteristics**4.1 Description**

Securing the positioner on the crimping tool is provided by the combined action of the two bayonets and the pressure from the internal spring on the central moving part (locator).

The appropriate longitudinal positioning of the contact with respect to the crimping tool indenters is performed by the contact butting against a shoulder on the central part bore.

4.2 Dimensions, mass

Dimensions of positioner are given in Figure 1.

Mass: 30 g max.

1) Published by: Department of Defense (DOD), the Pentagon, Washington D.C. 20301 USA.

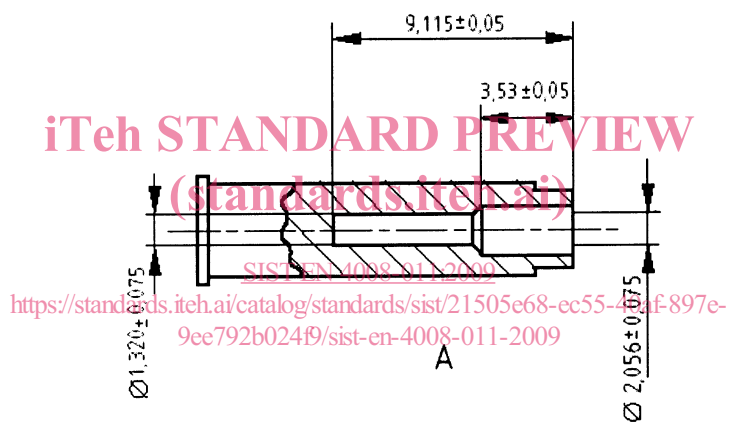
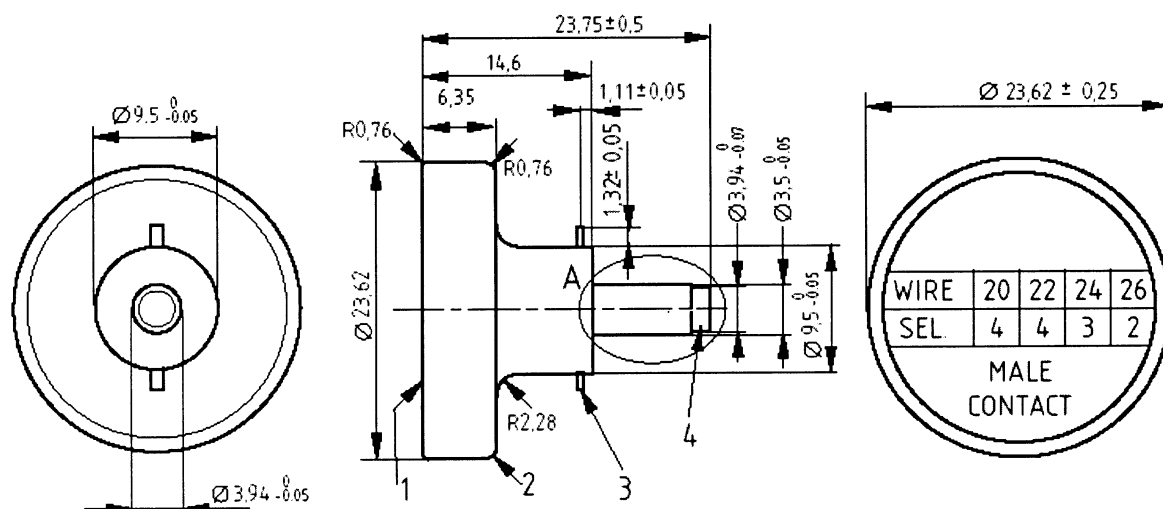
**Key**

- 1 Data plate
- 2 Manufacturer's name and part number
- 3 Bayonet lock pin
- 4 Locator in extended position

Figure 1 — Locator assembly

EN 4008-011:2006 (E)**4.3 Material, surface treatment**

Positioner body: aluminium alloy, colour blue.

Positioner ferrule: stainless steel.

5 Designation

EXAMPLE

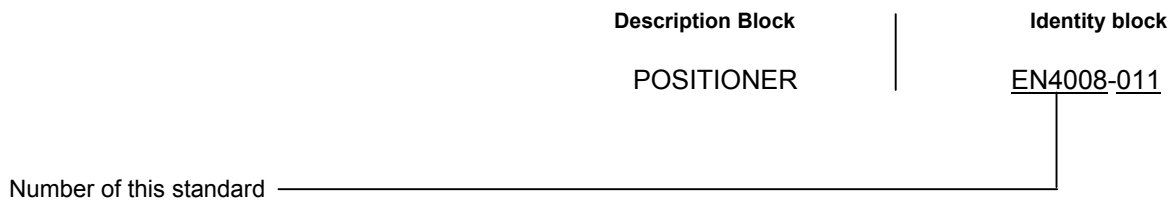

NOTE If necessary, the code I9005 shall be placed between the description block and the identity block.

6 Marking

See Figure 1.

iTeh STANDARD PREVIEW
(standards.iteh.ai)

7 Technical specification

See EN 4008-001.

[SIST EN 4008-011:2009](https://standards.iteh.ai/catalog/standards/sist/21505e68-ec55-40af-897e-9ee792b024f9/sist-en-4008-011-2009)
<https://standards.iteh.ai/catalog/standards/sist/21505e68-ec55-40af-897e-9ee792b024f9/sist-en-4008-011-2009>