Preskušanje strjenega betona - 8. del: Globina vpivanja vode pod pritiskom

Testing hardened concrete - Part 8: Depth of penetration of water under pressure

Prüfung von Festbeton - Teil 8: Wassereindringtiefe unter Druck

Essai pour béton durci - Partie 8: Profondeur de pénétration d'eau sous pression

Ta slovenski standard je istoveten z: EN 12390-8:2000[SIST EN 12390-8:2001](https://standards.iteh.ai/catalog/standards/sist/a09c0661-c83d-4ad5-9e7a-6f05b824f710/sist-en-12390-8-2001)<https://standards.iteh.ai/catalog/standards/sist/a09c0661-c83d-4ad5-9e7a-6f05b824f710/sist-en-12390-8-2001>**ICS:**

91.100.30	Beton in betonski izdelki	Concrete and concrete products
-----------	---------------------------	--------------------------------

SIST EN 12390-8:2001**en**

iTeh STANDARD PREVIEW
(standards.iteh.ai)

SIST EN 12390-8:2001

<https://standards.iteh.ai/catalog/standards/sist/a09c0661-c83d-4ad5-9e7a-6f05b824f710/sist-en-12390-8-2001>

EUROPEAN STANDARD

EN 12390-8

NORME EUROPÉENNE

EUROPÄISCHE NORM

October 2000

ICS 91.100.30

English version

Testing hardened concrete - Part 8: Depth of penetration of water under pressure

Essai pour béton durci - Partie 8: Profondeur de pénétration
d'eau sous pressionPrüfung von Festbeton - Teil 8: Wassereindringtiefe unter
Druck

This European Standard was approved by CEN on 18 February 2000.

CEN members are bound to comply with the CEN/CENELEC Internal Regulations which stipulate the conditions for giving this European Standard the status of a national standard without any alteration. Up-to-date lists and bibliographical references concerning such national standards may be obtained on application to the Management Centre or to any CEN member.

This European Standard exists in three official versions (English, French, German). A version in any other language made by translation under the responsibility of a CEN member into its own language and notified to the Management Centre has the same status as the official versions.

CEN members are the national standards bodies of Austria, Belgium, Czech Republic, Denmark, Finland, France, Germany, Greece, Iceland, Ireland, Italy, Luxembourg, Netherlands, Norway, Portugal, Spain, Sweden, Switzerland and United Kingdom.

iTeh STANDARD PREVIEW
(standards.itih.ai)

SIST EN 12390-8:2001
<https://standards.itih.ai/catalog/standards/sist/a09c0661-c83d-4ad5-9e7a-6f05b824f710/sist-en-12390-8-2001>



EUROPEAN COMMITTEE FOR STANDARDIZATION
COMITÉ EUROPÉEN DE NORMALISATION
EUROPÄISCHES KOMITEE FÜR NORMUNG

Management Centre: rue de Stassart, 36 B-1050 Brussels

Contents

	Page
Foreword	2
1 Scope	3
2 Principle	3
3 Apparatus	3
4 Test specimen	3
5 Procedure	3
6 Test result	4
7 Test report	4
8 Precision	4
Figure 1 - Example of test arrangement	5

Foreword

This European Standard has been prepared by Technical Committee CEN/TC 104 "Concrete (performance, production, placing and compliance criteria)", the secretariat of which is held by DIN.

This European Standard shall be given the status of a national standard, either by publication of an identical text or by endorsement, at the latest by April 2001, and conflicting national standards shall be withdrawn at the latest by December 2003.

According to the CEN/CENELEC Internal Regulations, the national standards organizations of the following countries are bound to implement this European Standard: Austria, Belgium, Czech Republic, Denmark, Finland, France, Germany, Greece, Iceland, Ireland, Italy, Luxembourg, Netherlands, Norway, Portugal, Spain, Sweden, Switzerland and the United Kingdom.

This standard is one of a series concerned with testing concrete.

It is based on the draft International Standard ISO (DIS) 7031 - Concrete hardened - Determination of the depth of penetration of water under pressure.

The standard has been restricted to tests on specimens cured in water.

The requirement in the original draft ISO Standard for the average depth of penetration to be estimated has been omitted.

A draft for this standard was published in 1996 for CEN enquiry as prEN 12364. It was one of a series of individually numbered test methods for fresh or hardened concrete. For convenience it has now been decided to combine these separate draft standards into three new standards with separate parts for each method, as follows:

- Testing fresh concrete (EN 12350)
- Testing hardened concrete (EN 12390)
- Testing concrete in structures (EN 12504)

The series EN 12390 includes the following parts where the brackets give the numbers under which particular test methods were published for CEN enquiry:

EN 12390 Testing hardened concrete

- Part 1: Shape, dimensions and other requirements of specimens and moulds (former prEN 12356 : 1996)
- Part 2: Making and curing specimens for strength tests (former prEN 12379 : 1996)
- Part 3: Compressive strength of test specimens (former prEN 12394 : 1996)
- Part 4: Compressive strength - Specification for testing machines (former prEN 12390 : 1996)
- Part 5: Flexural strength of test specimens (former prEN 12359 : 1996)
- Part 6: Tensile splitting strength of test specimens (former prEN 12362 : 1996)
- Part 7: Density of hardened concrete (former prEN 12363 : 1996)
- Part 8: Depth of penetration of water under pressure (former prEN 12364 : 1996)

1 Scope

This standard specifies a method for determining the depth of penetration of water under pressure in hardened concrete which has been water cured.

2 Principle

Water is applied under pressure to the surface of hardened concrete. The specimen is then split and the depth of penetration of the water front is measured.

3 Apparatus

3.1 Testing equipment

The test specimen, of given dimensions, shall be placed in any suitable equipment in such a manner that the water pressure can act on the test area and the pressure applied can be continuously indicated. An example of a test arrangement is shown in Figure 1.

NOTE 1 It is preferable that the apparatus should allow the other surfaces of the test specimen to be observed.

NOTE 2 The water pressure may be applied to the surface of the test specimen either from the bottom, or the top.

A necessary seal shall be made of rubber or other similar material.

The dimensions of a test area shall be approximately half of the length of the edge or diameter of the test surface.

4 Test specimen

The specimen shall be cubic, cylindrical or prismatic of length of edge, or diameter, not less than 150 mm.

<https://standards.iteh.ai/catalog/standards/sist/a09c0661-c83d-4ad5-9e7a-6f05b824f710/sist-en-12390-8-2001>

5 Procedure

5.1 Preparation of the test specimen

Immediately after the specimen is de-moulded, roughen the surface to be exposed to water pressure, with a wire brush.

5.2 Application of water pressure

The test shall be started when the specimen is at least 28 days old. Do not apply the water pressure to a trowelled surface of a specimen. Place the specimen in the apparatus and apply a water pressure of (500 ± 50) kPa for (72 ± 2) h. During the test, periodically observe the appearance of the surfaces of the test specimen not exposed to the water pressure to note the presence of water. If leakage is observed then consider the validity of the result and record the fact.

NOTE The use of tap water is satisfactory.

5.3 Examination of specimen

After the pressure has been applied for the specified time, remove the specimen from the apparatus. Wipe the face on which the water pressure was applied to remove excess of water. Split the specimen in half, perpendicularly to the face on which the water pressure was applied. When splitting the specimen, and during the examination, place the face of the specimen exposed to the water pressure on the bottom. As soon as the split face has dried to such an extent that the water penetration front can be clearly seen, mark the water front on the specimen. Measure the

maximum depth of penetration under the test area and record it to the nearest millimetre.

6 Test result

The maximum depth of penetration, expressed to the nearest millimetre, is the test result.

7 Test report

The report shall include:

- a) identification of the test specimen;
- b) date of start of the test;
- c) description of the specimen;
- d) direction of application of water pressure with respect to the casting direction;
- e) maximum depth of penetration, in millimetres;
- f) any leakage and consideration of the validity of the result; (if appropriate)
- g) any deviation from standard test method;
- h) a declaration by the person technically responsible for the test that it was carried out in accordance with this standard, except as noted in item g).

iTeh STANDARD PREVIEW
(standards.iteh.ai)

8 Precision

There is no precision data available.

SIST EN 12390-8:2001

<https://standards.iteh.ai/catalog/standards/sist/a09c0661-c83d-4ad5-9e7a-6f05b824f710/sist-en-12390-8-2001>

Dimensions in millimetres

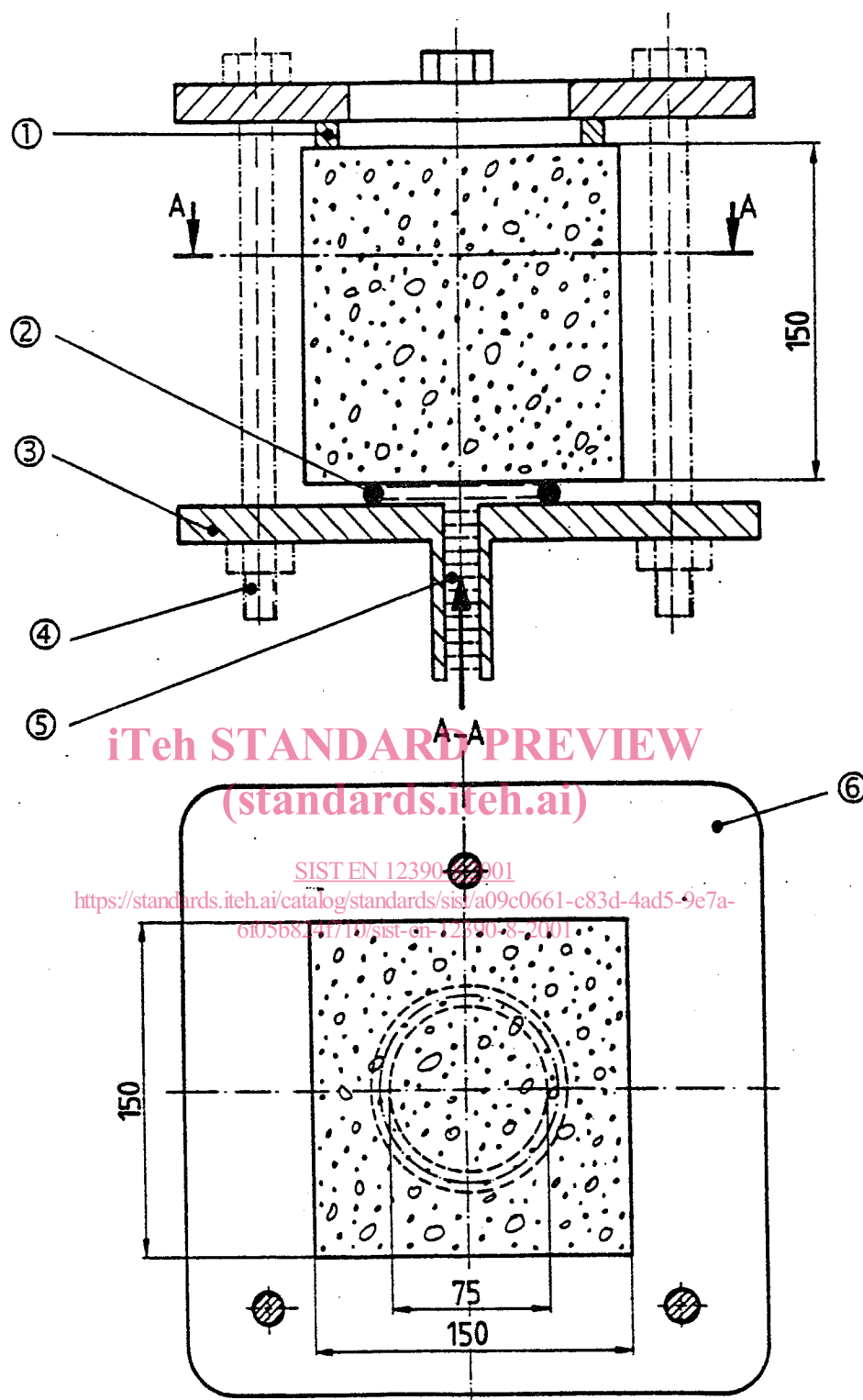
**Key**

- 1 Packing piece
- 2 Sealing ring
- 3 Scrowed on plate
- 4 Screw-threaded rod
- 5 Water under pressure
- 6 Scrowed on plate

Figure 1 - Example of test arrangement