

# INTERNATIONAL STANDARD

**ISO**  
**10648-1**

First edition  
1997-05-15

---

---

## **Containment enclosures —**

### **Part 1:** Design principles

iTeh Standards

(<https://standards.iteh.ai>)  
*Enceintes de confinement —*

*Partie 1: Principes de conception*

Document Preview

[ISO 10648-1:1997](https://standards.iteh.ai/catalog/standards/iso/834e73c8-ec47-4481-9288-9be4b5bb2f4/iso-10648-1-1997)

<https://standards.iteh.ai/catalog/standards/iso/834e73c8-ec47-4481-9288-9be4b5bb2f4/iso-10648-1-1997>



Reference number  
ISO 10648-1:1997(E)

## Contents

	Page
<b>1</b> Scope.....	<b>1</b>
<b>2</b> Normative references.....	<b>2</b>
<b>3</b> Definitions.....	<b>2</b>
<b>4</b> Characteristics of materials used .....	<b>3</b>
<b>5</b> Plastic containment enclosures.....	<b>4</b>
<b>6</b> Metal-framed containment enclosures.....	<b>6</b>
<b>7</b> Hot-worked metal containment enclosures .....	<b>11</b>
<b>8</b> Special case of containment enclosures with shielding .....	<b>20</b>
<b>Annexes</b>	
<b>A</b> Seals for containment enclosures.....	<b>23</b>
<b>B</b> Fully equipped containment enclosure.....	<b>27</b>
<b>C</b> Bibliography .....	<b>28</b>

<https://standards.iteh.ai/catalog/standards/iso/834e73c8-ec47-4481-9288-9be4b5bbf2f4/iso-10648-1-1997>

<https://standards.iteh.ai/catalog/standards/iso/834e73c8-ec47-4481-9288-9be4b5bbf2f4/iso-10648-1-1997>

© ISO 1997

All rights reserved. Unless otherwise specified, no part of this publication may be reproduced or utilized in any form or by any means, electronic or mechanical, including photocopying and microfilm, without permission in writing from the publisher. / Droits de reproduction réservés. Sauf prescription différente, aucune partie de cette publication ne peut être reproduite ni utilisée sous quelque forme que ce soit et par aucun procédé, électronique ou mécanique, y compris la photocopie et les microfilms, sans l'accord écrit de l'éditeur.

International Organization for Standardization  
Case postale 56 • CH-1211 Genève 20 • Switzerland  
Internet central@iso.ch  
X.400 c=ch; a=400net; p=iso; o=isocs; s=central

Printed in Switzerland/Imprimé en Suisse

## Foreword

ISO (the International Organization for Standardization) is a worldwide federation of national standards bodies (ISO member bodies). The work of preparing International Standards is normally carried out through ISO technical committees. Each member body interested in a subject for which a technical committee has been established has the right to be represented on that committee. International organizations, governmental and non-governmental, in liaison with ISO, also take part in the work. ISO collaborates closely with the International Electrotechnical Commission (IEC) on all matters of electrotechnical standardization.

Draft International Standards adopted by the technical committees are circulated to the member bodies for voting. Publication as an International Standard requires approval by at least 75 % of the member bodies casting a vote.

International Standard ISO 10648-1 was prepared by Technical Committee ISO/TC 85, *Nuclear energy*, Subcommittee SC 2, *Radiation protection*.

ISO 10648 consists of the following parts, under the general title *Containment enclosures*:

- *Part 1: Design principles*
- *Part 2: Classification according to leak tightness and associated checking methods*

Annexes A, B and C of this part of ISO 10648 are for information only.

## Introduction

This part of ISO 10648 provides guidance and recommendations for the design, mounting and assembly of containment enclosures. It gives general requirements on the materials to be used, the construction of the different types of containment enclosure: plastic enclosures, metal profile enclosures or hot-worked metal enclosures which can be used either alone or placed behind a shielding wall and, finally, standard dimensions for these different categories of containment enclosure.

Other requirements and important design and safety features, such as operating conditions, internal atmosphere, ventilation, illumination, electrical grounding and shock prevention, ergonomic considerations, etc., will be addressed in other International Standards. The risk of fire, explosion, or violent chemical reaction should also be considered when applying the design principles of this part of ISO 10648.

It is not intended to describe here a systematic procedure for risk assessment in order to select adequate and consistent construction measures. The risk assessment should consider the following different stages, including design, manufacture, construction, assembly, operation, maintenance, decommissioning of containment enclosures and waste management or disposal, as appropriate. This task should be undertaken by every designer, with respect to the exact intended use of the containment enclosure and in order to comply, if required, with relevant safety standards or regulations.

# Containment enclosures —

## Part 1: Design principles

### 1 Scope

This part of ISO 10648 applies to enclosures or enclosure lines intended to be used for work on:

- radioactive and/or toxic products where containment is required for protection of personnel and environment,
- sensitive products requiring a special atmosphere and/or a sterile medium.

This part of ISO 10648 deals with three types of containment enclosure:

- glove boxes,
- tong boxes, and
- containment enclosures with larger dimensions, used with remote manipulators mounted behind independent shielding.

Some dimensions of the last two types will be given in a subsequent International Standard dealing with the mounting of tongs and manipulators.

The following enclosures have been deliberately excluded from the scope of this part of ISO 10648:

- pressurized vessels,
- ventilated hoods,
- shielded enclosures, manufactured from concrete only, with or without cladding, or from lead only,
- sealed sources,
- transport packaging for radioactive materials,
- enclosures, primary circuits and vessels of nuclear reactors.

This part of ISO 10648 describes the use and principles of design for containment enclosures chosen as reference examples of the three following types:

- plastic enclosures,
- metal-framed enclosures,
- hot-worked metal enclosures.

The last two types can be mounted behind shielding or can have directly attached shielding.

Where standard dimensions are not suitable, other dimensions may be chosen but the containment enclosure shall comply with this part of ISO 10648 in design principles, mounting and assembly. It shall also comply with relevant safety standards and regulations.

Examples of various seals available and the assembly of containment enclosures are shown in annexes A and B. ISO 10648-2 gives the classification of containment enclosures according to their leak tightness and associated checking methods.

Associated equipment will be detailed in future International Standards.

## 2 Normative references

The following standards contain provisions which, through reference in this text, constitute provisions of this part of ISO 10648. At the time of publication, the editions indicated were valid. All standards are subject to revision, and parties to agreements based on this part of ISO 10648 are encouraged to investigate the possibility of applying the most recent editions of the standards indicated below. Members of IEC and ISO maintain registers of currently valid International Standards.

ISO 468:1982, *Surface roughness — Parameters, their values and general rules for specifying requirements*.

ISO 1302:1992, *Technical drawings — Method of indicating surface texture*.

ISO 7212:1986, *Enclosures for protection against ionizing radiation — Lead shielding units for 50 mm and 100 mm thick walls*.

ISO 9404-1:1991, *Enclosures for protection against ionizing radiation — Lead shielding units for 150 mm, 200 mm and 250 mm thick walls — Part 1: Chevron units of 150 mm and 200 mm thickness*.

ISO 10648-2:1994, *Containment enclosures — Part 2: Classification according to leak tightness and associated checking methods*.

## 3 Definitions

For the purposes of this part of ISO 10648, the following definitions apply.

**3.1 enclosure:** System which ensures the separation between a specified work volume (or internal environment) and a surrounding space (or external environment) in which the human operators are generally to be found.

**3.2 containment enclosure:** Enclosure designed to prevent the leakage of the products contained in the internal concerned environment into the external environment, or the penetration of substances of the external environment into the internal environment, or both simultaneously.

NOTE — This is the generic term to designate all kinds of enclosures, including glove boxes or boxes equipped with remote handling devices.

**3.3 glove box:** Containment enclosure that permits the operator to safely handle toxic or radioactive materials or products from outside the enclosure using gloves tightly sealed onto glove ports fitted into the panels of the enclosure.

## 4 Characteristics of materials used

### 4.1 Choice of materials for the containment enclosure

The choice of constituent materials is always a compromise between various requirements. The designer shall take into account the requirements for mounting and fitting. The constituent materials of the containment enclosure can be classified into three groups:

- plastics,
- glass,
- metal alloys (painted carbon steel, stainless steel, light alloys).

The general characteristics of each of these groups are given in 4.2 to 4.4.

### 4.2 Plastics

The main characteristics of plastics are:

- light weight and generally low cost,
- transparency for some types of viewing panels,
- good resistance to chemical agents except certain aggressive solvents, e.g. tributyl phosphate (TBP),
- variable mechanical strength according to material quality and working temperature,
- poor resistance to UV radiation,
- limited resistance to gamma radiation,
- poor ease of decontamination,
- high fire load<sup>1)</sup>,
- permeability to water vapour.

<https://standards.iteh.ai/>  
ISO 10648-1:1997

<https://standards.iteh.ai/catalog/standards/iso/834e73e8-ec47-4481-9288-9be4b5bb2f4/iso-10648-1-1997>

### 4.3 Glass

The main characteristics of glass are:

- good resistance to chemical agents except hydrochloric acid and hydrogen fluoride,
- good temperature resistance,
- poor resistance to mechanical and thermal shock (except laminated glass),
- difficult to work, store, handle, particularly laminated glass,
- impermeability to water vapour,
- poor radiation resistance (except stabilized glass),
- ease of decontamination,
- low fire load.

---

1) When using plastics, the effect of the increase in calorific potential per unit mass should be taken into account.

For these reasons, only special types of toughened, laminated and stabilized glass shall be used as structural material in containment enclosures. Special precautions are required when being handled, stored or modified (adding new ports, for example).

## 4.4 Metal alloys

### 4.4.1 Carbon or stainless steels

The main characteristics of carbon or stainless steels are:

- good temperature resistance,
- possibility of modular construction,
- ease of decontamination (stainless steel),
- good mechanical strength,
- good radiation resistance,
- no fire load,
- not transparent,
- more expensive than plastics,
- high weight.

Carbon steels require surface treatment to protect them against corrosion and to simplify the decontamination procedure. Some types of stainless steel exhibit good chemical resistance.

### 4.4.2 Light alloys

The main characteristics of light alloys are:

- good rigidity and ease of machining,
- structures lighter than steels,
- possibility of modular construction,
- difficult to weld,
- low fire load,
- possibility of mechanical damage by sharp objects

Their temperature resistance are limited (not above 800 °C).

## 5 Plastic containment enclosures

This type of containment enclosure is produced in many different designs, shapes and sizes. Several models are standardized.

### 5.1 Use

These containment enclosures can belong to class 1, 2 or 3 (see ISO 10648-2) but shall not be used with dry air or neutral gases because of their permeability to water vapour.

They are recommended for the handling of corrosive chemical products, with the exclusion of certain solvents (TBP) (see 4.2).



Their use is not recommended for the handling of aerosols (or material easily forming aerosols) having a high specific activity, due to the destruction of the molecular structure of the plastic under radiation emitted by deposited materials and problems associated with static electricity.

They generate a fire load higher than hot-worked metal enclosures having the same dimensions.

## 5.2 Description

Containment enclosures are manufactured from two plastics: polyvinylchloride (PVC) or polymethylmethacrylate (PMMA). See figure 1.

Plastic material may be transparent or opaque. The enclosure may be totally or partially transparent, but the front panel should use transparent material.

The enclosure should provide one or two workplaces equipped with glove ports.

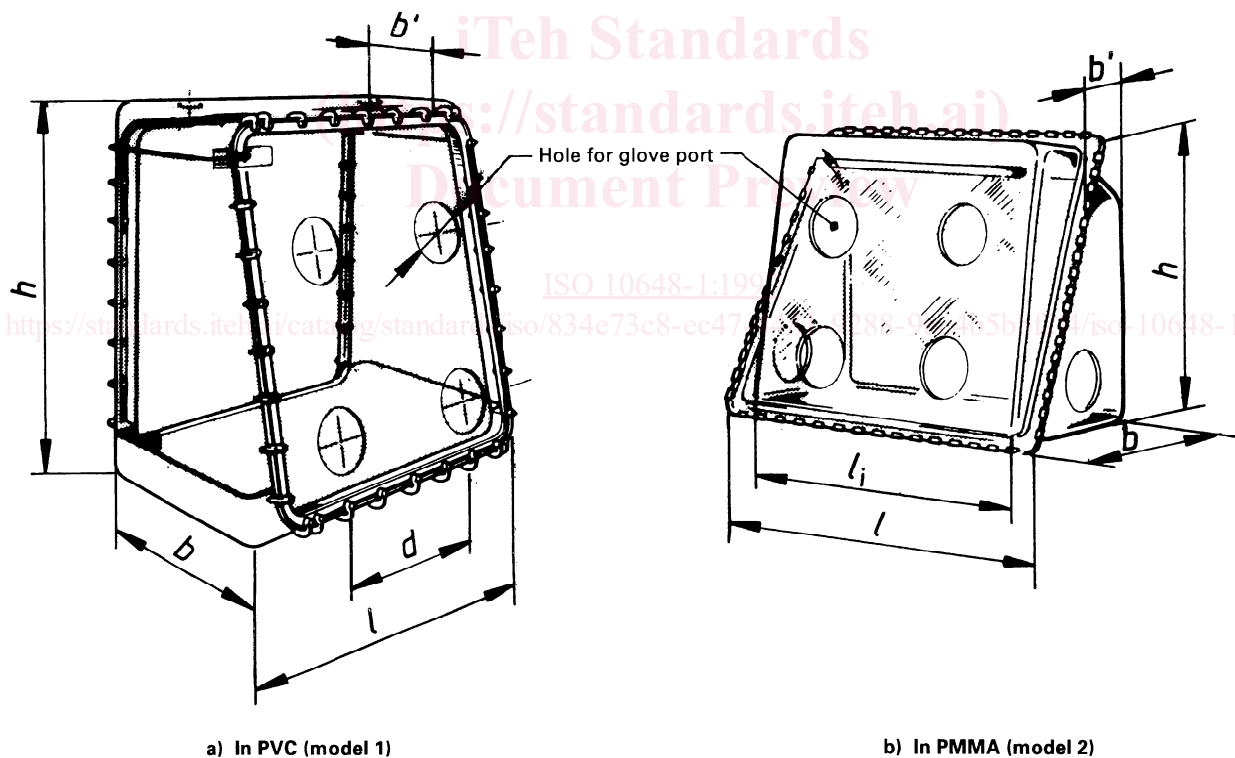

Figure 1 — Plastic containment enclosures

### 5.3 Design

Containment enclosures in PVC or PMMA can be bonded or thermoformed.

These containment enclosures can be placed directly on a laboratory benchtop or, more usually, on an appropriate support.

The front and back, which are removable, are fixed on by clamps or by flexible clips. All corners are rounded for ease of decontamination. The bottom is flat and is press-formed in the shape of a tray.

### 5.4 Dimensions

Standard dimensions of plastic containment enclosures are given in table 1.

**Table 1 — Dimensions of plastic containment enclosures**

Dimensions in millimetres

Model	Length		Width		Height <i>h</i>	Recommended interaxial distance, <i>d</i> (glove/bag port spacing)
	overall <i>l</i>	inner <i>l<sub>i</sub></i>	base <i>b</i>	upper part <i>b'</i>		
1	1 000	—	630	390	1 000	460
1 (variation)	1 080	—	600	500	1 000	450
2	1 180	1 080	730	620	1 020	470

## 6 Metal-framed containment enclosures

### 6.1 Use

The enclosures can be used in conditions of either negative or positive pressure, thus complying with the requirements for nuclear (protection against contamination), biological or medical applications.

These containment enclosures can achieve a high degree of leak tightness (class 1 or 2, see ISO 10648-2).

When handling of aerosols (or material easily forming aerosols) having a high specific activity, or in the presence of corrosive or reactive substances, the seals should be protected with an appropriate mastic.

Because of their modular design, they:

- allow a workplace on each side,
- can be easily adapted for special processes,
- are suitable for heavy machines or complex operations.

They can also be manufactured in larger sizes because of their rigid construction.

NOTE — Contaminated or damaged panels can be replaced using special procedures in accordance with local regulations applicable in the establishment concerned.

## 6.2 Description

These containment enclosures comprise a metallic framework onto which are mounted transparent panels equipped with glove ports.

These containment enclosures are generally parallelepipeds (see figures 2 and 3) with one (or two) vertical working face(s) each having two, three or four glove ports.

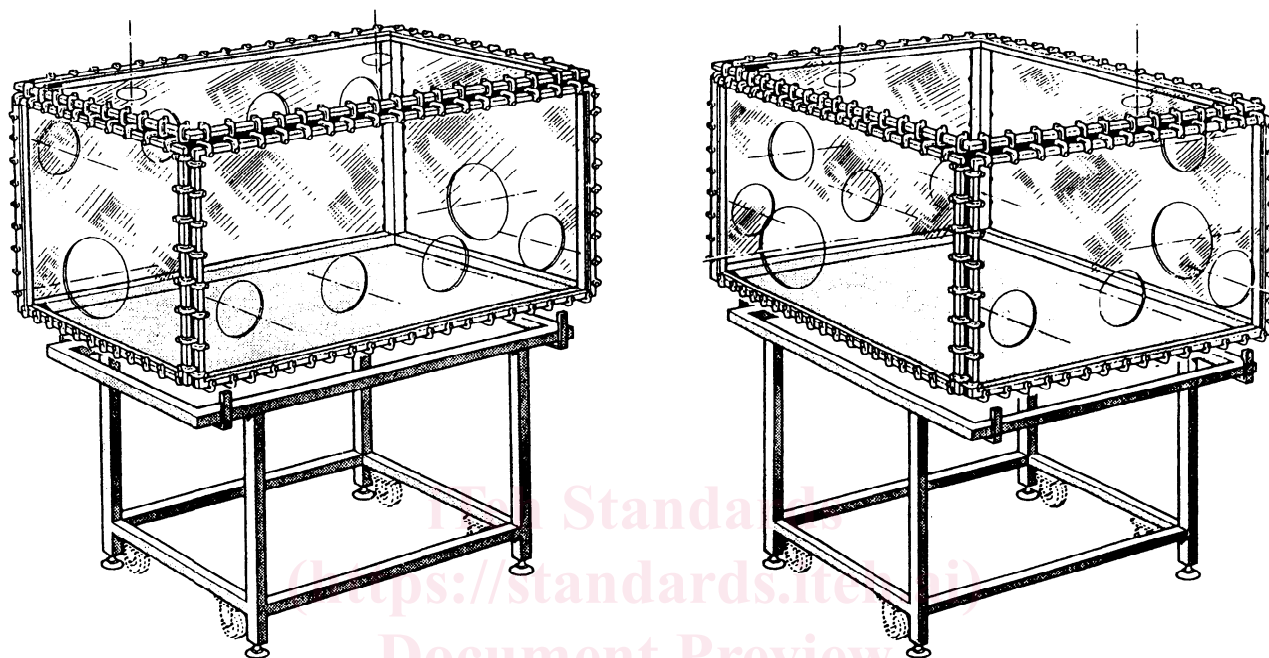

Figure 2 — Metal-framed containment enclosures (examples)

## 6.3 Design

The framework of the enclosure shall be made of painted carbon steel or stainless steel. The transparent panels are mounted on the framework with clamps or flexible clasp (see figure 4).

Leak tightness is ensured by seals which are compressed between the framework and the panel. When clamps are used, an external frame is required to tighten the panels onto the framework.

Various types of the most usual seals, with their main characteristics, are given in annex A.

### 6.3.1 Framework

The framework is made of stainless steel or painted carbon steel.

Different types of metal shapes are in use; the most common are:

- 2,5 mm thick bent sheet metal (also called omega profile) (see figure 4, column A),
- 2 mm thick square tubing (see figure 4, column B),
- angle profile tubing (also called L-profile tubing) (see figure 5).

Two or more frames can be mounted together, as shown in figure 6, in order to extend the length and/or the height of the containment enclosure. Care should be taken to provide sufficient stiffness to prevent a loss of sealing.