



Designation: C1270 – 97 (Reapproved 2003)

# Standard Practice for Detection Sensitivity Mapping of In-Plant Walk-Through Metal Detectors<sup>1</sup>

This standard is issued under the fixed designation C1270; the number immediately following the designation indicates the year of original adoption or, in the case of revision, the year of last revision. A number in parentheses indicates the year of last reapproval. A superscript epsilon ( $\epsilon$ ) indicates an editorial change since the last revision or reapproval.

## INTRODUCTION

Nuclear regulatory authorities require personnel entering designated security areas to be screened for concealed weapons. Additionally, in security areas containing specified quantities of special nuclear materials, exiting personnel are required to be screened for metallic nuclear shielding material. Walk-through metal detectors are widely used to implement these requirements.

A number of environmental conditions, architectural and electrical arrangements near the detector, and detector characteristics affect the detection of metallic objects passing through the walk-through metal detector. These external effects and detector characteristics are discussed in Practices [F1468](#) and [C1269](#), and Guide [C1238](#). This practice is intended to minimize the effects of these variables on detector operation by providing the operator with baseline information on the metal detection sensitivity within the portal aperture, particularly the location of any weak areas of detection. The data is obtained by mapping the detection zone (volume within the portal) of each detector at its field location, under normal operating conditions, and using the target test object. The maps, when applied to detector operation, ensure that the effects of the fixed environmental conditions, architectural and electrical arrangements, and detector characteristics are taken into account during operational sensitivity adjustment, performance evaluation, and general operation of detectors.

## 1. Scope

1.1 This standard practice covers a procedure for determining the weakest detection path through the portal aperture and the worst-case orthogonal orientation of metallic test objects. It results in detection sensitivity maps, which model the detection zone in terms related to detection sensitivity and identify the weakest detection paths. Detection sensitivity maps support sensitivity adjustment and performance evaluation procedures (see Practices [C1269](#) and [C1309](#)).

NOTE 1—Unsymmetrical metal objects possessing a primary longitudinal component, such as handguns and knives, usually have one particular orientation that produces the weakest detection signal. The orientation and the path through the detector aperture where the weakest response is produced may not be the same for all test objects, even those with very similar appearance.

NOTE 2—In the case of multiple specified test objects or for test objects that are orientation sensitive, it may be necessary to map each object several times to determine the worst-case test object or orientation, or both.

1.2 This practice is one of several developed to assist operators of walk-through metal detectors with meeting the metal detection performance requirements of the responsible regulatory authority. (See [Appendix X2](#))

1.3 This practice is neither intended to set performance levels, nor limit or constrain operational technologies.

1.4 This practice does not address safety or operational issues associated with the use of walk-through metal detectors.

1.5 The values stated in SI units are to be regarded as the standard. The values given in parentheses are for information only.

## 2. Referenced Documents

2.1 *ASTM Standards*:<sup>2</sup>

[C1238 Guide for Installation of Walk-Through Metal Detectors](#)

[C1269 Practice for Adjusting the Operational Sensitivity Setting of In-Plant Walk-Through Metal Detectors](#)

[C1309 Practice for Performance Evaluation of In-Plant Walk-Through Metal Detectors](#)

<sup>1</sup> This practice is under the jurisdiction of ASTM Committee [C26](#) on Nuclear Fuel Cycle and is the direct responsibility of Subcommittee [C26.12](#) on Safeguard Applications.

Current edition approved Feb. 10, 2003. Published February 2003. Originally approved in 1994. Last previous edition approved in 1997 as C1270 – 97. DOI: 10.1520/C1270-97R03.

<sup>2</sup> For referenced ASTM standards, visit the ASTM website, [www.astm.org](http://www.astm.org), or contact ASTM Customer Service at [service@astm.org](mailto:service@astm.org). For *Annual Book of ASTM Standards* volume information, refer to the standard's Document Summary page on the ASTM website.

**F1468 Practice for Evaluation of Metallic Weapons Detectors for Controlled Access Search and Screening**

**3. Terminology**

**3.1 Definitions of Terms Specific to This Standard:**

3.1.1 *clean-tester, n*—a person who does not carry any extraneous metallic objects that would significantly alter the signal produced when the person carries a test object.

3.1.1.1 *Discussion*—By example but not limitation, such extraneous metallic objects may include: metallic belt buckles, metal buttons, cardiac pacemakers, coins, metal frame eye glasses, hearing aids, jewelry, keys, mechanical pens and pencils, shoes with metal shanks or arch supports, metallic surgical implants, undergarment support metal, metal zippers, etc. In the absence of other criteria, a clean tester passing through a metal detector shall not cause a disturbance signal greater than 10 % of that produced when carrying the critical test object through the detector. Test objects requiring very high sensitivity settings for detection require more complete elimination of extraneous metal to obtain less than 10 % signal disturbance.

3.1.1.2 *Discussion*—The tester shall have a weight between 50 to 104 kg (110 to 230 lb) and a height between 1.44 to 1.93 m (57 to 75 in.). Should a given detector be sensitive to body size because of design or desired sensitivity, the physical size of testers should be smaller and within a narrower range.

3.1.1.3 *Discussion*—It is recommended that the clean tester be surveyed with a high sensitivity hand-held metal detector to ensure that no metal is present.

3.1.2 *critical orientation, n*—the orthogonal orientation of a test object that produces the smallest detection signal or weakest detection anywhere in the detection zone; the orthogonal orientation of a test object that requires a higher sensitivity setting to be detected compared to the sensitivity setting required to detect the object in all other orthogonal orientations. See Fig. 1 for handgun orientations.

3.1.2.1 *Discussion*—Critical orientations are determined by testing using a mapping procedure such as described in Practice C1270.

3.1.2.2 *Discussion*—The term critical orientation can refer to the worst case orthogonal orientation in a single test path or

the worst case orthogonal orientation for all the test paths (the entire detection zone). The two are coincident in the critical test path.

3.1.3 *critical sensitivity setting, n*—the lowest sensitivity setting of a detector at which the critical test object in its critical orientation is consistently detected (10 out of 10 test passes) when passed through the detection zone on the critical test path.

3.1.4 *critical test element, n*—see **test element**.

3.1.5 *critical test object, n*—see **test object**.

3.1.6 *critical test path, n*—the straight-line shortest-course path through the portal aperture, as defined by an element on the detection sensitivity map, that produces the smallest detection signal or weakest detection for a test object in its critical orientation. (see Figs. 2 and 3)

3.1.7 *detection sensitivity map, n*—(see Figs. 2 and 1) a depiction of the grid used to define test paths through the detection zone, with each element of the grid containing a value, usually the sensitivity setting of the detector, that is indicative of the detectability of the test object.

3.1.7.1 *Discussion*—These values are relative and describe the detection sensitivity pattern within the detection zone for the specific test object. The values are derived by identically testing each defined test path using a specific test object in a single orthogonal orientation. The value is usually the minimum sensitivity setting of the detector that will cause a consistent alarm (10 out of 10 test passes) when the test object is passed through the detection field. Appendix X3 is a sample form for a potential detection sensitivity map configuration.

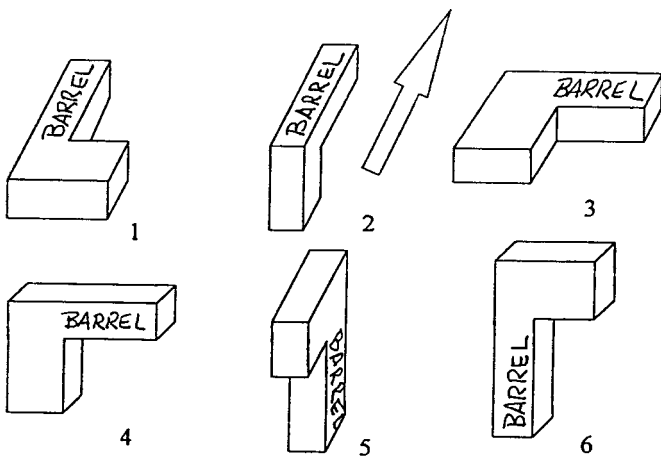

**FIG. 1 Six Standard Orthogonal Orientations for a Handgun**

52	68	52	52
49	55	75	71
50	52	75	73
48	58	74	70
35	63	81	72
47	62	89	74
47	69	79	75
57	71	81	79
62	74	74	69

critical test element

NOTE 1—Numbers are sensitivity setting values for a hypothetical detector. The numbers represent the lowest sensitivity setting at which the object was detected ten out of ten consecutive test passes through the indicated test path.

NOTE 2—Important: ensure that the location of the transmitter and receiver are identified. If the detector does not have a dedicated transmitter and receiver, note the side from which testing is performed relative to the protected area.

**FIG. 2 Example of Detection Sensitivity Map**

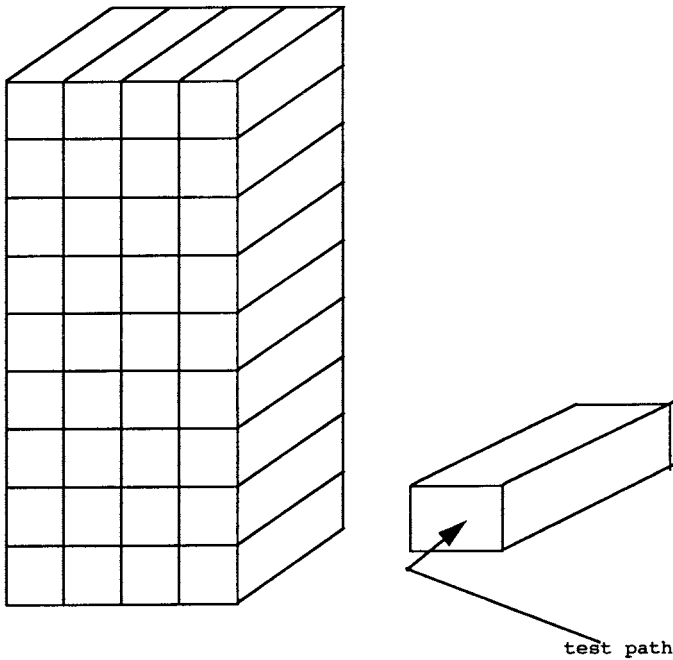

FIG. 3 3-D View of Detection Zones and Test Grid

3.1.8 *detection zone, n*—the volume within the portal aperture.

3.1.9 *detector, n*—see **walk-through metal detector**.

3.1.10 *element, n*—see test element

3.1.11 *grid, n*—see test grid

3.1.11.1 *grid element, n*—(1) a single block on a detection sensitivity map; (2) the rectilinear volume through the detection zone defined by coincident elements of identical grid works placed on either side of the portal aperture. (see Figs. 2 and 3)

3.1.11.2 *test path, n*—as defined by an element on a detection sensitivity map, a straight-line shortest-course path through the detection zone of a detector undergoing mapping, detection sensitivity, or detection sensitivity verification testing. (see Fig. 3)

3.1.12 *element, test element, n*—for the purpose of this testing, a test element is the volume of space defined by the boundaries of two corresponding network openings, and it represents a straight-line shortest-course path through the detection zone.

3.1.12.1 *Discussion*—It is necessary to define discrete and repeatable straight-line shortest-course test paths through the detection zone. This can be done by using two identical networks (grids) made of nonconductive/nonmagnetic material attached across the entry and exit planes of the portal aperture so the networks coincide. A test object on the end of a probe can then be passed from one side of the portal aperture to the other side through corresponding openings, which results in the test object taking a reasonably straight-line shortest-course path through the detection zone. If the networks are constructed so that they can be put in-place identically each time they are used, then the test paths through the detection zone are repeatable over time. On a detection sensitivity map the

corresponding networks appear as a rectangular grid with each element of the grid representing a test path through the detection zone.

3.1.13 *in-plant, adj*—installed in the location, position, and operating environment where the device will be used.

3.1.14 *orthogonal orientation, n*—as used in this practice, orthogonal orientation refers to alignment of the longitudinal axis of a test object along the xyz axes of the Cartesian coordinate system; x is horizontal and across the portal, y is vertical, and z is in the direction of travel through the portal. (see Fig. 1 for handgun orientations)

3.1.15 *portal, n*—see **walk-through metal detector**.

3.1.16 *test element, n*—(see Figs. 2 and 3) for the purpose of testing, it is necessary to define discrete and repeatable straight-line shortest-course test paths through the detection zone. This can be done by using two identical networks (grids) made of nonconductive/nonmagnetic material attached across the entry and exit planes of the portal aperture so the networks coincide. A test object on the end of a probe can then be passed from one side of the portal aperture to the other side through corresponding openings, which results in the test object taking a reasonably straight-line shortest-course path through the detection zone. If the networks are constructed so that they can be put in-place identically each time they are used, then the test paths through the detection zone are repeatable over time. Thus, a test element is the volume of space defined by the boundaries of two corresponding network openings and it represents a straight-line shortest-course path through the detection zone.

3.1.16.1 *Discussion*—On a detection sensitivity map the corresponding networks appear as a rectangular grid with each element of the grid representing a test path through the detection zone. The element defining the critical test path is the critical test element.

3.1.17 *test grid, n*—a network of nonconductive/nonmagnetic material, such as string or tape, can be stretched across the entry and exit planes of the portal aperture to define test paths through the portal aperture; the material should not be hygroscopic.

3.1.17.1 *Discussion*—See Fig. 2 for an example of a 4 by 9 element test grid.

3.1.18 *test object, n*—metallic item meeting dimension and material criteria used to evaluate detection performance.

3.1.18.1 *critical test object*—the one test object out of any given group of test objects that in its critical orientation, produces the weakest detection signal anywhere in the detection zone.

3.1.18.2 *Discussion*—Depending on the particular detector, some orientation sensitive test objects may have different locations in the detection zone result in near critical sensitivity settings. Hence, care must be taken in determining the critical test object, its critical orientation, and the critical test path.

3.1.18.3 *shielding test object, n*—a test object representing special nuclear material shielding that might be used in a theft scenario.

3.1.18.4 *Discussion*—It is usually a metallic container or metallic material configured as a credible gamma-radiation shield for a specific type and quantity of special nuclear

material. The object is specified by a regulatory authority or is based on the facility threat analysis, or both.

3.1.18.5 *weapon test object, n*—a handgun(s) or simulated handgun designated by or satisfying the regulatory authority requirement for a test object.

3.1.18.6 *Discussion*—Care must be taken when selecting or designing a mock handgun. Simple blocks of metal shaped like a handgun will likely not cause a metal detector to react the same as it would to the intricate shapes and variable components of a real handgun. Most government agencies use actual guns for testing.

3.1.19 *walk-through metal detector (detector, portal), n*—a free-standing screening device, usually an arch-type portal, using an electromagnetic field within its portal structure (aperture) for detecting metallic objects, specifically weapons or metallic shielding material, or both, on persons walking through the portal.

3.1.20 *walk speed (Normal), n*—walk speed is between 0.5 to 1.3 m/s (1 ½ to 2 ½ steps/s).

3.1.20.1 *Discussion*—The average casual walk rate is about 1 ¾ step/s.

3.1.20.2 *shielding test object, n*—see **test object**.

3.1.20.3 *weapon test object, n*—see **test object**.

#### 4. Summary of Practice

4.1 This practice describes a method for determining the metal detection sensitivity pattern within the aperture of walk-through metal detectors. It develops detection sensitivity maps for walk-through metal detectors. These maps are depictions of the grids used to define test paths through the detector with values in each element that are representative of the detection sensitivity (see Fig. 2). The values are derived by identically testing each element with the same test object in a specific orthogonal orientation. The maps identify areas of weak detection and are used during sensitivity adjustment and performance testing to assure complete detection coverage throughout the detector aperture.

4.2 This practice describes two methods for determining the values that make up the detection sensitivity map:

4.2.1 In the first, a test object, which is usually specified by requirements of the responsible regulatory authority, is passed through the detection zone in each of the identified test paths and the sensitivity is adjusted to determine the lowest sensitivity setting that results in consistent detection of the test object in each test path. These settings are the critical sensitivity settings and are the value entered in the respective elements of the detection sensitivity map.

4.2.2 If a detector has a numeric readout that is representative of the actual signal from which the detector determines an alarm condition, this value may be used for describing the detection sensitivity pattern. In this case, a specified test object is passed through each test path several times and the mean value of the responses is calculated for each element (the sensitivity adjustment must be set at a level that provides less than full scale readings for the most sensitive path through the detection zone). These mean values describe the sensitivity pattern.

4.3 Test objects that are orientation sensitive must have each orthogonal orientation tested to determine the worst-case orientation.

#### 5. Significance and Use

5.1 A complex set of variables affect metal detection and detection sensitivity. Some physical characteristics of metal objects that influence detection are material composition, shape, surface area, surface and internal electrical and magnetic properties, and finish. The orientation of a test object can greatly influence detection as can the direction and speed or changes in speed while passing through the detection zone. Nearby large metal objects and metal moving in near proximity to a metal detector also affect operation, as do temperature and humidity, and can be a cause for nuisance alarms. Additionally, most currently manufactured walk-through metal detectors have some means for programming the operation of the detector for special conditions or requirements; these variables and the effect they have on the operation of in-plant detectors must be considered if a test program is to be effective. This practice is intended to minimize the impact of these variables on the operation of in-plant detectors by systematically testing the installed detectors in the operating environment with the test object(s) specified by the regulatory authority requirements.

5.2 This practice may be used to determine the critical test object from a group of test objects, its critical orientation, and the critical test path through the detection zone. This information may allow the use of a single test object for setting the operational sensitivity of the detector and performing periodic performance evaluations necessary to ensure a high probability that all test objects in the group are detectable within the capabilities of the detector.

5.3 The detection sensitivity map(s) generated by this practice provides baseline metal detection data for the specified test objects and can serve as a foundation for in-plant walk-through metal detector set-up and performance evaluation testing. The detection sensitivity map(s) may be incorporated into a detector performance test log in support of performance evaluation practices.

5.4 This practice may provide insight into certain metal detection characteristics of walk-through metal detectors, particularly the effect of different metals and test object orientations on detection capability, that are useful for optimizing detector sensitivity settings for detection of specified weapons or shielding material, or both.

5.5 Periodic performance of this practice and analysis of the results may provide a means to monitor the state of health of in-plant detectors and to gain further insight into detector application and operation.

#### 6. Test Objects

6.1 The test objects are generally specified or approved, or both, by the responsible regulatory authority.

#### 7. Interferences

7.1 During performance of this practice and during normal operation of walk-through metal detectors, every attempt