



Designation: C 687 – 02

# Standard Practice for Determination of Thermal Resistance of Loose-Fill Building Insulation<sup>1</sup>

This standard is issued under the fixed designation C 687; the number immediately following the designation indicates the year of original adoption or, in the case of revision, the year of last revision. A number in parentheses indicates the year of last reapproval. A superscript epsilon ( $\epsilon$ ) indicates an editorial change since the last revision or reapproval.

## 1. Scope

1.1 This practice presents a laboratory guide to determine the thermal resistance of loose-fill building insulations at mean temperatures between  $-20$  and  $55^{\circ}\text{C}$  ( $-4$  to  $131^{\circ}\text{F}$ ).

1.2 This practice applies to a wide variety of loose-fill thermal insulation products including fibrous glass, rock/slag wool, or cellulosic fiber materials; granular types including vermiculite and perlite; pelletized products; and any other insulation material that may be installed pneumatically or poured in place. It does not apply to products that change their character after installation either by chemical reaction or the application of binders or adhesives, nor does it consider the effects of structures, containments, facings, or air films.

1.3 Since this practice is designed for reproducible product comparison, it measures the thermal resistance of an insulation material which has been preconditioned to a relatively dry state. Consideration of changes of thermal performance of a hygroscopic insulation by sorption of water is beyond the scope of this practice.

1.4 The sample preparation techniques outlined in this practice do not cover the characterization of loose-fill materials intended for enclosed applications. For those applications, a separate sample preparation technique that simulates the installed condition will be required. For those applications, however, other aspects of this practice should be applicable.

1.5 The values stated in SI units are to be regarded as the standard. The values given in parentheses are for information only.

1.6 *This standard does not purport to address all of the safety concerns, if any, associated with its use. It is the responsibility of the user of this standard to establish appropriate safety and health practices and determine the applicability of regulatory limitations prior to use.*

## 2. Referenced Documents

### 2.1 ASTM Standards:

C 167 Test Methods for Thickness and Density of Blanket

or Batt Thermal Insulations<sup>2</sup>

C 168 Terminology Relating to Thermal Insulating Materials<sup>2</sup>

C 177 Test Method for Steady-State Heat Flux Measurements and Thermal Transmission Properties by Means of the Guarded-Hot-Plate Apparatus<sup>2</sup>

C 518 Test Method for Steady-State Heat Flux Measurements and Thermal Transmission Properties by Means of the Heat Flow Meter Apparatus<sup>2</sup>

C 653 Guide for Determination of the Thermal Resistance of Low-Density Blanket-Type Mineral Fiber Insulation<sup>2</sup>

C 739 Specification for Cellulosic Fiber (Wood Base) Loose-Fill Thermal Insulation<sup>2</sup>

C 1045 Practice for Calculating Thermal Transmission Properties from Steady-State Heat Flux Measurements<sup>2</sup>

C 1114 Test Method for Steady-State Thermal Transmission Properties by Means of the Thin-Heater Apparatus<sup>2</sup>

C 1363 Test Method for Thermal Performance of Building Assemblies by Means of a Hot Box Apparatus<sup>2</sup>

## 3. Terminology

3.1 Unless otherwise stated, the terms and definitions found in Terminology C 168 are applicable herein.

3.2 *label density*—the expected mass per unit volume, after long-term settlement, of a loose-fill insulation that has been applied per manufacturer's specifications. This density (test density) will yield the labeled thermal resistance when tested under the conditions specified by this practice.

## 4. Significance and Use

4.1 The thermal resistance,  $R$ , of an insulation is used to describe its thermal performance.

4.2 The thermal resistance of an insulation is related to the density and thickness of the insulation. It is desirable to obtain test data on thermal resistances at thicknesses and densities related to the end uses of the product.

4.3 In normal use, the thickness of these products may range from less than 100 mm (4 in.) to greater than 500 mm (20 in.). Installed densities will depend upon the product type, the installed thickness, the installation equipment used, the installation techniques, and the geometry of the insulated space.

<sup>1</sup> This practice is under the jurisdiction of ASTM Committee C16 on Thermal Insulation and is the direct responsibility of Subcommittee C16.30 on Thermal Measurement.

Current edition approved Dec. 10, 2002. Published March 2003. Originally approved in 1971. Last previous edition approved in 1996 as C 687 – 96.

<sup>2</sup> *Annual Book of ASTM Standards*, Vol 04.06.

4.4 Loose-fill insulations are specified using label densities selected by manufacturers to represent the product settled densities. Generally, it is necessary to know the product thermal performance at a representative label density. Some bag labels utilize multiple label densities to reflect the fact that greater thickness installations usually result in higher installed densities. The use of multiple label densities can be detected from the bag label by calculating the label density for several different *R*-value levels. (The label densities for a given *R*-value can be calculated from the bag label by dividing the minimum mass per unit area by the minimum thickness.) If the calculated densities are significantly different, the multiple label density strategy has been used.

4.5 When applicable specifications or codes do not specify the nominal *R*-value level to be used for comparison purposes, a recommended practice is to use the R-19 label density and thickness for that measurement. [*R* (metric) – 3.3 m<sup>2</sup>K/W].

4.6 If the density for test purposes is not available from the bag label, a test density shall be established by use of either applicable specifications and codes or, if none apply, agreement between the requesting body and the testing organization.

4.7 Generally, thin sections of these materials are not uniform. Thus, the representative thickness must be exceeded during the test, if the results are to be consistent and typical of use. The representative thickness is specific for each product and may be determined by running a series of tests in which the density is held constant but the thickness is increased. The representative thickness shall be that test thickness above which there is no more than a 2 % change in the resistivity of the product.

4.7.1 For purposes of this practice, the minimum test thickness shall be 100 mm (4 in.) or the representative thickness whichever is larger. If the test is to represent an installation at a lesser thickness, that installed thickness should be used.

4.8 Because of the high cost of construction and operation of large test equipment, it is often impractical to test at the thickness at which products are used. For purposes of this practice, it is acceptable to estimate the thermal resistance at any thickness from the thermal resistivity obtained from tests on the product at the minimum test thickness (see 4.7.1) and at the design density expected for the proposed thickness.

4.9 In principle, any of the standard methods for the determination of thermal resistance are suitable for loose-fill products. These include Test Methods C 177, C 518, C 1114, and C 1363. Of these test methods, the heat flow meter apparatus, Test Method C 518, is preferred because of its lower cost and shorter testing time.

4.10 The thermal resistance of low-density insulations may depend on the direction of heat flow. Attic applications will have heat flow-up during the winter and heat flow-down during the summer. If seasonal differences are significant, then tests should be conducted with heat flow in each direction. Unless otherwise specified, tests shall be performed for the maximum heat flow condition—a horizontal specimen with heat flow-up.

4.11 Specimens shall be prepared in a manner consistent with the intended installation procedure. Products for pneumatic installation shall be pneumatically applied (blown), and products for pour-in-place installation shall be poured into specimen frames.

## 5. Apparatus

5.1 Thermal test apparatus used for this practice shall meet these requirements.

5.1.1 *Conformance to Standards*—The apparatus shall conform to all requirements of the ASTM thermal test method used.

5.1.2 *Size and Error*—The apparatus shall be capable of testing specimens up to at least 150-mm (6-in.) thickness with an estimated error not greater than 1 % attributed to thickness/guard dimensions. (Parametric studies using a mathematical model of the proposed apparatus will give insight to this evaluation. For example see Table 1 in the 1976 revision of Test Method C 518.<sup>3</sup>)

NOTE 1—Thermal test apparatus in use for this practice have overall plate dimensions of 457 to 1220 mm (18 to 48 in.) square with test areas 152 to 457 mm (6 to 18 in.) square. Other sizes may be acceptable if proper consideration of the size-thickness restrictions outlined are observed in their design. (See Practice C 1045 for additional discussion.)

5.1.3 *Temperature*—As a minimum, the apparatus must be capable of testing at a mean temperature of 23.9°C (75°F) with a temperature difference of 20 to 28°C (36 to 40°F). The equipment must be calibrated at the same temperatures as the test conditions. Existing test apparatus have been designed to provide measurements over a range of mean temperatures from –20 to 55°C (–4 to 131°F) and for a wider range of temperature differences.

5.1.4 *Humidity*—The absolute humidity within the test apparatus shall be maintained low enough to prevent condensation within the specimen or on the cold plate(s). A maximum 9°C (48°F) dew point is consistent with the recommended material conditioning levels.

5.1.5 *Orientation and Direction of Heat Flow*—The thermal test apparatus must be capable of testing horizontal specimens with heat flow-up in order to include possible internal convective effects. This orientation represents the most adverse heat flow condition for testing between two solid boundaries. Additional capability such as testing horizontal specimens with heat flow-down or vertical specimens with heat flow horizontal, or both, may also be desirable. (See 10.1.7 for reporting requirements.)

5.1.6 *Thermal Test Specimen Frame*—The test frame shall be sized to match the test apparatus and shall be made of materials having low thermal conductivity (<0.12 W/m K) and minimum thickness. A thin, thermally insignificant, screen or membrane is stretched across the bottom to support the material. Frames may have fixed rigid sides or fold-down, collapsible, or compressible sides (see Fig. 1 and Fig. 2).

5.2 *Specimen Preparation Equipment:*

<sup>3</sup> See Table 1, “Maximum Spacing Between Warm and Cold Plates of Heat Flowmeter Apparatus,” of Test Method C 518 – 76 published in 1985 *Annual Book of ASTM Standards*, Vol 04.06.

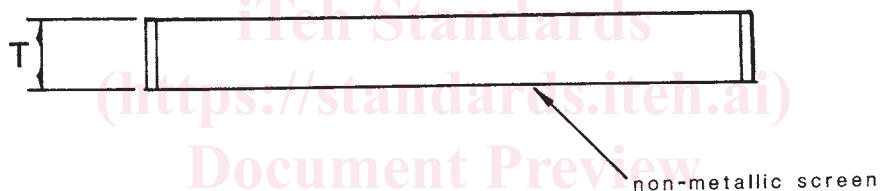
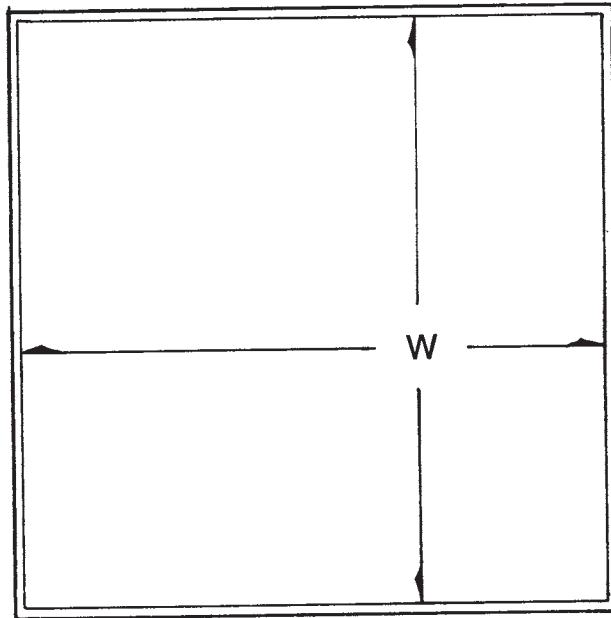

NOTE 1—Dimensions to match thermal test apparatus.

FIG. 1 Rigid Test Frame

<https://standards.iteh.ai/catalog/standards/sist/385b890e-0734-40d8-80b6-f5a93f31f84d/astm-c687-02>

5.2.1 *Blowing Machine*—A blowing apparatus is required when pneumatically applied specimens are to be tested. Choose the combination of hopper, blower, and hose size and length that is representative of common use for the application of the material to be tested. The following machine specifications have been developed for use with mineral wool and cellulosic materials.

5.2.1.1 *Mineral Fiber Insulations:*

(1) *Blowing Machine*—A commercial blowing machine with a design capacity for delivering the subject material at a rate between 4 and 15 kg (9 to 33 lb)/min.

NOTE 2—In case of dispute, for mineral fiber insulations a 75 mm (3 in.) hose shall be used to prepare the specimens.

(2) *Blowing Hose*—The machine should utilize 46 m (150 ft) of typical 75 to 100 mm (3 to 4 in.) diameter flexible, internally corrugated blowing hose. At least 30 m (100 ft) of the hose should be elevated between 3 and 6 m (10 and 20 ft) above the blowing machine to simulate a typical installation configuration. The hose should have no more than eight 90° bends and no bends may be less than 1.2-m (4-ft) radius. It is good practice to clean the hose periodically by mechanically agitating it with the blower on. This practice should dislodge any pieces of old insulation that might be caught in the hose.

5.2.1.2 *Cellulosic Insulations:*

(1) *Blowing Machine*—Use commercial blowing equipment designed for cellulosic material, that is, hopper, blower, and 30 m (100 ft) of typical 50 to 75 mm (2 to 3 in.) diameter hose.

(2) *Settled Density Catch Containers*—Containers shall be sized to match the test frames and shall be made of plywood or similar materials. A thin sheet of plywood attached across the bottom supports the insulation. Frames should have fixed sides.

NOTE 3—In case of dispute, for cellulosic insulations a 51 mm (2 in.) hose shall be used to prepare the specimens

5.2.2 *Test Area Specimen Cutter*—A means for isolating the material within the metering area is required for the density determination. The isolated region shall have an area and shape identical to the metering area. Fig. 3 provides an example of a die cutter used for this purpose. The use of a compression plate to compress an area larger than the metering area, prior to metering area material removal is recommended. This compression plate should extend at least 75 mm (3 in.) beyond the metering area boundary.

5.2.3 *Weighing Devices*—A device is required to weigh the test area material after the thermal test is complete. This device must determine the test area weight to within 0.5 %. A second device is required during sample preparation and conditioning

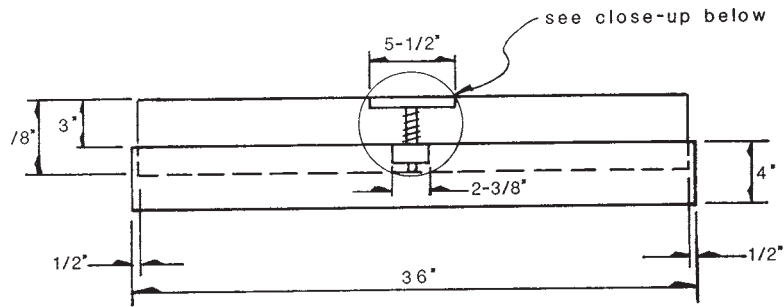

FRONT VIEW

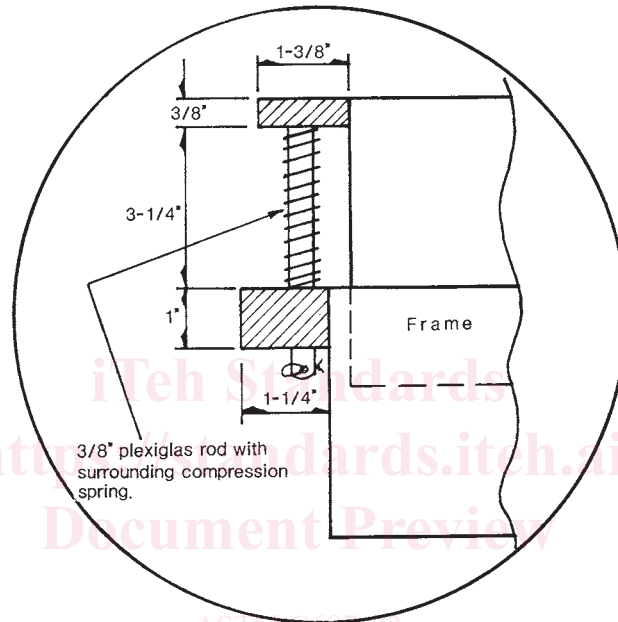

SIDE VIEW DETAIL

FIG. 2 Collapsible Test Frame (an Example)

to determine the sample plus frame weight. This device must weigh the combined weight to within 0.5 %.

5.2.4 *Conditioning Room*—An enclosure held at near constant temperature and humidity is required to stabilize the materials or products prior to testing. The room conditions may be given in product specifications or in other appropriate documents. In the absence of specific directions, conditioning shall be carried out in an atmosphere of  $23 \pm 2^\circ\text{C}$  ( $75 \pm 4^\circ\text{F}$ ) and a relative humidity not greater than 45 % (see 5.1.4).

5.2.5 *Specimen Support Sheet*—A stiff cardboard or equivalent sheet to be used to support the specimen during preparation, conditioning, and transport.

5.2.6 *Specimen Preparation Room*—A semi-enclosed area where the test material is blown into the specimen frame is required. This enclosure protects the blowing operation from wind or strong air currents. The room should not influence the blowing stream from the hose. Minimum room dimensions of 3 by 3 by 2.5 m (10 by 10 by 8 ft) are generally adequate for this purpose. Experience has shown that, to obtain uniform specimens, it is necessary to blow an area greater than the

dimensions of the specimen frame. The recommended area to be covered is at least 2.5 times the minimum test frame dimension.

## 6. Sampling

6.1 Sampling plans given in the material specifications, regulations, or other appropriate documents shall be followed when applicable. In the absence of such directions, material from at least two randomly chosen packages shall be combined in equal portions (weight) and placed in the blowing machine so as to combine materials as uniformly as practicable. Alternatively, multiple tests can be performed where each specimen is made from a single package.

6.2 The insulation material should be preconditioned at laboratory conditions prior to the specimen blowing, if necessary, to remove excess moisture added during the manufacturing process. Preconditioning of materials not only ensures controlled blowing conditions but may reduce the time required to condition the prepared specimen prior to thermal testing. For cellulosic materials, the preconditioning guideline is defined in Specification C 739.

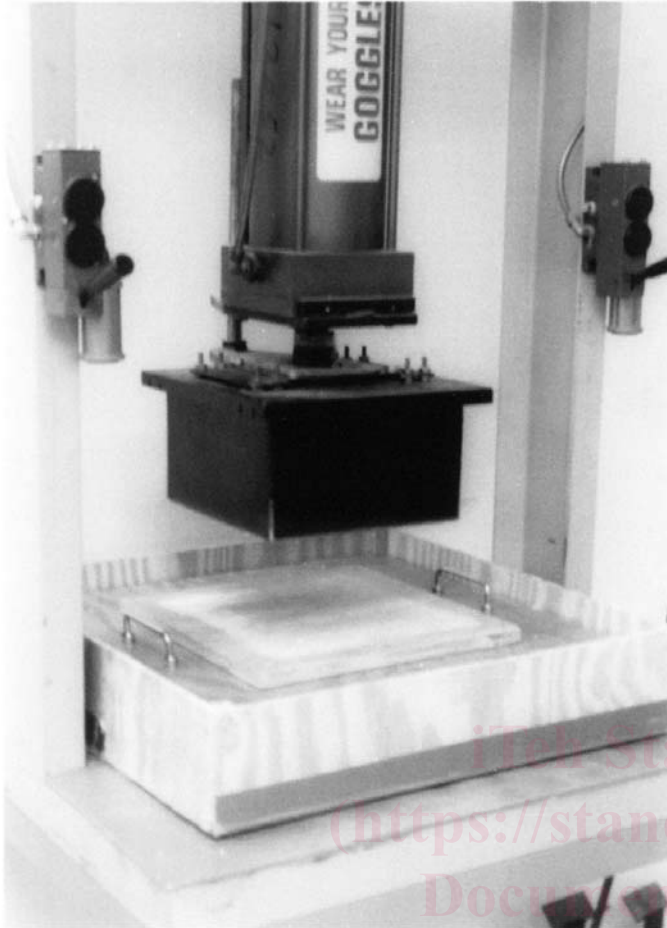

Note 1—Use of a pressure plate to compress a loose-fill specimen prior to cutting the metering area.

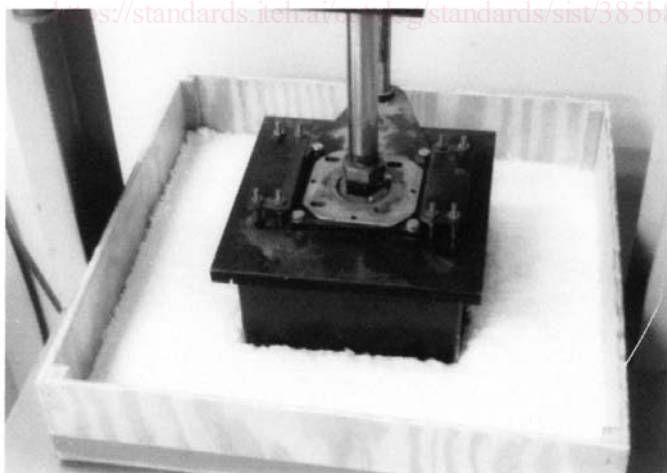

Note 2—Use of a hydraulic die cutter to cut the metering area. Note the compressed specimen after using the pressure plate.

FIG. 3 Test Area Cutter

## 7. Specimen Preparation

### 7.1 Pneumatic Application—General Materials:

7.1.1 The procedure described in this section is intended for products which are normally installed pneumatically which do

not exhibit settling under normal installed conditions. Use Paragraph 7.2 for pneumatically installed products where the specimen preparation must be modified to accommodate a correction for settling after installation.

NOTE 4—For commonly available loose-fill insulations, state and federal energy codes, ASTM material specifications, and the Federal Trade Commission have identified those materials which must apply a correction for settling when determining thermal performance. It is beyond the scope of this practice to outline the procedures for this determination.

7.1.2 The specimen preparation room should be clean and free of old insulation prior to the start of specimen preparation.

NOTE 5—Many factors can influence the characteristics of the blown insulation. These include blowing rate, machine adjustments, the size and length of the hose, and the angle and dimensions of the hose outlet in relation to the test frame. Trained operators are required to duplicate field-installed conditioning. Some users of this method have constructed a support structure that holds the hose end at the proper orientation. This may remove some of the operator dependency during the blowing operation.

NOTE 6—For ease of specimen preparation, the specimen should be blown close to the desired test density. Some operators may wish to establish a target weight of insulation required to fill the test frame as a control during the specimen preparation process. By placing the specimen frame and support sheet on a scale in the specimen preparation room while blowing occurs, it is possible to blow only the mass of the insulation targeted for the test. Other operators may wish to eliminate these extra steps. The reported test density, however, is obtained from the metering area density measurement conducted after the thermal test.

7.1.3 If the specimen is to be blown to a predetermined density, calculate the target weight of insulation required to fill the test frame to the target thickness and density. If the intent is to test the material at whatever density is blown, then this calculation is not required.

7.1.4 Assemble the blowing machine, hose, and hose length combination as appropriate for the material being prepared (see recommendations in 5.2.1.1).

7.1.5 Set the blowing machine adjustments and select the feed rates in accordance with the insulation manufacturer's recommendations. If the insulation manufacturer does not provide this information, consult the machine manufacturer for recommended settings.

7.1.6 Place at least two packages (see 6.1) of the insulation material into the blowing machine hopper. If the hopper is too small to hold two packages of material, fill the hopper to capacity with equal portions of material from two packages.

7.1.7 Place the thermal specimen holder on the specimen support sheet in the center of the specimen preparation area (see Note 6).

7.1.8 Turn on the blowing machine with the hose outlet directed away from the test specimen frame. Do not blow the thermal test specimen until a steady flow of insulation material has been achieved.

7.1.9 Once steady flow is achieved, (approximately 30 to 45 s), direct the hose outlet toward the test specimen frame. The hose outlet should be horizontal and at a height above the test specimen frame of no less than 0.9 m and no greater than 1.2 m (3 to 4 ft). This height is measured from the centerline of the hose opening.

7.1.10 The end of the loose-fill trajectory should fall beyond the test specimen frame at the start of the blow. The operator

should then back up slowly, allowing the end of the trajectory to fall into the specimen frame. While continuing to back up, the operator will slowly change the direction of the hose approximately  $\pm 45^\circ$  in a horizontal plane to uniformly fill the test specimen frame. The operator should continue to make passes back and forth until the specimen frame is filled to approximately one half of the target thickness.

7.1.11 When the test specimen frame is approximately one half full, point the hose away from the test frame and stop the blowing machine. Remove all excess insulation from around the test frame, being careful not to disturb the insulation inside. Carefully rotate the test frame and support sheet  $180^\circ$  from their original position. Do not jar the frame or cause any unnecessary settling of the insulation. During handling of the blown specimen, keep the support sheet firmly against the bottom of the specimen frame.

NOTE 7—For some insulation materials, it is not necessary to rotate the specimen frame during blowing in order to prepare a uniform specimen. However, in case of dispute, the specimen preparation procedure listed, herein, should be followed carefully.

7.1.12 Restart the blowing machine, establish flow as in 7.1.8, and continue to fill the test specimen frame.

7.1.13 Continue blowing the material into the test frame until it is uniformly full and there is a slight excess above the target test thickness. Do not exceed 50 % excess thickness while blowing. For specimen preparation controlled by weight, the control must be a maximum of 110 % of the target weight in addition to the thickness limit stated in 7.1.3.

NOTE 8—If the intent is to test at label density and the specimen exceeds the upper mass limit without reaching the target thickness or exceeds the upper thickness limit without meeting the target mass, a new specimen must be prepared.

NOTE 9—Care should be observed when handling or moving the filled specimen frame so as not to disturb the test specimen any more than is absolutely necessary. Any vibration or impact can change the pack structure of the blown sample and change its thermal properties.

7.1.14 Remove the surrounding excess material from the area of the test frame. Move the specimen frame and support sheet to a flat level table.

7.1.15 Remove excess material to reach a level thickness that is no greater than 115 % of target test thickness. Do not disturb the remaining material, preserving it in the as-blown condition.

7.1.16 Move the specimen frame and its accompanying support sheet to the specimen conditioning room.

7.1.17 Condition the specimen and frame for sufficient time to reach constant weight (less than 1.0 % weight change in 24 h).

## 7.2 Pneumatic Application—Settled Density Method:

7.2.1 This method is intended for pneumatically installed products where the specimen preparation must be modified to accommodate a correction for settling after installation.

NOTE 10—Although this section is specific to cellulosic insulations, the principles outlined can be used for other insulations requiring correction for settled density, providing that the appropriate blowing equipment and settling simulation method (see 7.2.13) is used. Reference should be made to the appropriate material specification to make this determination.

7.2.2 Assemble the blowing machine, hose, and hose length combination as appropriate for the insulation material being prepared. (See recommendations in 5.2.1.2.)

7.2.3 With the blower turned off, turn on the agitator in the hopper and load just enough insulation to cover the agitator.

7.2.4 Allow the agitator to run until the material appears to be thoroughly broken apart.

7.2.5 Hold the hose so the outlet is horizontal and at a height above the test specimen frame of no less than 0.9 m and no greater than 1.2 m (3 to 4 ft). This height is measured from the centerline of the hose opening. Turn on the blower and adjust the air slide on the inlet side of the blower until excessive dust begins to appear. Back off air slightly and record the setting. During this process, manually add insulation to the hopper to keep the agitator in the hopper covered.

7.2.6 Turn off the equipment and clean the specimen preparation room.

7.2.7 Place the thermal test frame on top of the support sheet in the center of the specimen preparation room and rotate the assembly  $45^\circ$  so that the diagonal of the specimen is in line with the blowing direction. Position four additional catch containers around the four sides on the test frame so as to create an “x” pattern.

7.2.8 Turn on the agitator and add insulation to the hopper until the agitator is covered.

7.2.9 Position the hose end as in 7.2.5 and, using the same air settings for the blower, turn on the blower. Once uniform flow is established, begin filling the test boxes at the rear of the specimen preparation room as follows. The end of the loose-fill trajectory should fall beyond the test specimen frame at the start of the blow. The operator should then back up slowly, allowing the end of the trajectory to fall into the specimen frame and catch containers. While continuing to back up, the operator will slowly change the direction of the hose approximately  $\pm 45^\circ$  in a horizontal plane to uniformly fill the test specimen frame. The operator should continue to make passes back and forth until the specimen frame is filled to the target thickness. The agitator should be covered at all times during the blowing process.

7.2.10 Fill the containers to a depth even with the level of the catch containers. Do not overfill above the side extensions.

7.2.11 When the catch containers and the test frame have been filled, gently screed the insulation flush with the top edge of the extensions. Avoid any vibration, compression, or compaction that might alter the blown density.

7.2.12 Weigh the catch containers and determine the average blown density using the net weight contained in each.

7.2.13 Take one or more of the four catch containers and determine the settled density of the insulation using the blower cyclone shaker (BCS) test in accordance with Specification C 739: skip the specimen preparation steps listed which use the commercial blower and hopper.

7.2.14 Carefully remove the surrounding excess material from the area of the test frame. Move the test box and its accompanying support sheet to the specimen conditioning room.