



SLOVENSKI STANDARD
SIST EN 12617-3:2002

01-november-2002

Dfc[nj cX]]b`g]ghYa]`nUnUy]rc`]b`dcdfUj]c`VYrcbg_]` _cbglfi _VY^!`DfYg_i gbY
a YrcXY!` "XY. `8c`c Yj Ub^Y`n[cXb^Y[U`]bYUrbY[U`_f Yb^U`_cbglfi _VY`g_]` Yd]

Products and systems for the protection and repair of concrete structures - Test methods
- Part 3: Determination of early age linear shrinkage for structural bonding agents

Produkte und Systeme für den Schutz und die Instandsetzung von Betontragwerken -
Prüfverfahren - Teil 3: Bestimmung des zeitlichen Verlaufs des linearen Schrumpfens
von Klebstoffen

(standards.iteh.ai)

Produits et systemes pour la protection et la réparation des structures en béton -
Méthodes d'essai - Partie 3: Détermination du retrait linéaire au jeune âge pour les
produits de collage structural

Ta slovenski standard je istoveten z: EN 12617-3:2002

ICS:

91.080.40	Betonske konstrukcije	Concrete structures
91.100.10	Cement. Mavec. Apno. Malta	Cement. Gypsum. Lime. Mortar

SIST EN 12617-3:2002 en

iTeh STANDARD PREVIEW
(standards.iteh.ai)

SIST EN 12617-3:2002

<https://standards.iteh.ai/catalog/standards/sist/958e1300-648f-47c4-a6cc-730839cb5f61/sist-en-12617-3-2002>

EUROPEAN STANDARD
NORME EUROPÉENNE
EUROPÄISCHE NORM

EN 12617-3

May 2002

ICS 91.080.40; 91.100.10

English version

Products and systems for the protection and repair of concrete structures - Test methods - Part 3: Determination of early age linear shrinkage for structural bonding agents

Produits et systèmes pour la protection et la réparation des structures en béton - Méthodes d'essai - Partie 3: Détermination du retrait linéaire au jeune âge pour les produits de collage structural

Produkte und Systeme für den Schutz und die Instandsetzung von Betontragwerken - Prüfverfahren - Teil 3: Bestimmung des zeitlichen Verlaufs des linearen Schrumpfens von Klebstoffen

This European Standard was approved by CEN on 4 January 2002.

CEN members are bound to comply with the CEN/CENELEC Internal Regulations which stipulate the conditions for giving this European Standard the status of a national standard without any alteration. Up-to-date lists and bibliographical references concerning such national standards may be obtained on application to the Management Centre or to any CEN member.

This European Standard exists in three official versions (English, French, German). A version in any other language made by translation under the responsibility of a CEN member into its own language and notified to the Management Centre has the same status as the official versions.

CEN members are the national standards bodies of Austria, Belgium, Czech Republic, Denmark, Finland, France, Germany, Greece, Iceland, Ireland, Italy, Luxembourg, Malta, Netherlands, Norway, Portugal, Spain, Sweden, Switzerland and United Kingdom.



EUROPEAN COMMITTEE FOR STANDARDIZATION
COMITÉ EUROPÉEN DE NORMALISATION
EUROPÄISCHES KOMITEE FÜR NORMUNG

Management Centre: rue de Stassart, 36 B-1050 Brussels

Contents

	page
Foreword.....	3
1 Scope	4
2 Principle	4
3 Equipment.....	4
4 Method	5
5 Calculation of shrinkage	5
6 Test report	6
Bibliography	8

iTeh STANDARD PREVIEW (standards.iteh.ai)

[SIST EN 12617-3:2002](https://standards.iteh.ai/catalog/standards/sist/958e1300-648f-47c4-a6cc-730839cb5f61/sist-en-12617-3-2002)

<https://standards.iteh.ai/catalog/standards/sist/958e1300-648f-47c4-a6cc-730839cb5f61/sist-en-12617-3-2002>

Foreword

This document EN 12617-3 been prepared by Technical Committee CEN/TC 104 "Concrete and related products", the secretariat of which is held by DIN.

This European Standard shall be given the status of a national standard, either by publication of an identical text or by endorsement, at the latest by November 2002, and conflicting national standards shall be withdrawn at the latest by December 2002.

It was prepared by sub-committee 8 "Products and systems for the protection and repair of concrete structures", the secretariat of which is held by AFNOR.

This European Standard is one of a series of inter-related parts dealing with dimensional stability repair products and systems. The other parts are:

prEN 12617-1, *Products and systems for the protection and repair of concrete structures - Test methods – Part 1: Determination of linear shrinkage.*

prEN 12617-2, *Products and systems for the protection and repair of concrete structures - Test methods – Part 2: Determination of volumetric shrinkage.*

EN 12617-4, *Products and systems for the protection and repair of concrete structures - Test methods – Part 4: Determination of shrinkage and expansion.*

According to the CEN/CENELEC Internal Regulations, the national standards organizations of the following countries are bound to implement this European Standard: Austria, Belgium, Czech Republic, Denmark, Finland, France, Germany, Greece, Iceland, Ireland, Italy, Luxembourg, Malta, Netherlands, Norway, Portugal, Spain, Sweden, Switzerland and the United Kingdom.

EN 12617-3:2002 (E)

1 Scope

This European Standard specifies a method for the determination of the early age linear shrinkage of structural bonding agents covered by EN 1504-1 and prEN 1504-4. It describes the procedures for the measurement of linear shrinkage from initial gel of polymer, in the form of unrestrained thin strips less than 10 mm in thickness. It is intended for measurement of early age shrinkage, for example up to 24 hours.

2 Principle

In principle the test is as follows : A freshly mixed sample of polymer shall be placed into a shallow steel trough shaped mould, the inside of which has been treated to prevent adhesion to the polymer. The mould has sliding ends which bond to the polymer and are free to move as the polymer expands or contracts. Linear displacement transducers attached to the ends enable the shrinkage to be measured. Temperature sensors attached to the mould enable the temperature of the mould and the polymer to be measured.

3 Equipment

3.1 Mould

A mould comprising a 400 mm long pressed steel trough supported on an insulating base and fitted with sliding stop ends, as shown in Figure 1.

The sliding ends shall fit the cross section of the trough with a clearance of 0,1 mm. The inside of the trough is coated with polytetrafluoroethylene (PTFE). Disposable linings which have surfaces prepared to enable the polymer samples to adhere to them are attached to the inner faces of the sliding ends. (A mechanical linkage may be needed for some polymers). Probes of linear displacement transducers are attached to the outer faces of the sliding ends. A thermocouple is attached at the centre of the underside of the mould which enables any exothermic temperature rise that occurs during the hardening (curing) of the polymer to be measured.

3.2 Linear displacement transducers

Linear transducers which are capable of measuring to an accuracy of $\pm 0,01$ mm over a range of 5 mm and of producing an output which can be recorded on an automatic recorder.

3.3 Thermocouples

Thermocouples connected into a signal conditioning unit with automatic cold junction compensation, which gives a linear output proportional to temperature so that the temperature of the polymer can be measured at any time during the hardening period.

3.4 Automatic recorder(s)

An automatic recorder or recorders capable of recording the movements measured by the linear transducers according to 4.2 over a period of 24 hours and the temperature changes during hardening according to 4.3.

3.5 Environmental cabinet

An environmental cabinet large enough to contain the mould as described in 4.1 in a horizontal position and capable of maintaining temperature $(21 \pm 2) ^\circ\text{C}$ and relative humidity $(60 \pm 10) \%$.

4 Method

4.1 Sampling material

The polymer to be tested shall be taken from one production batch of mortar. Each specimen shall be representative of the polymer being assessed.

4.2 Number of test specimens

A minimum of three specimens shall be tested.

4.3 Conditioning of test materials

All materials shall be conditioned in the test cabinet as described in 4.5 for 24 hours to reach the required temperature.

The surfaces of the mould which come into contact with the polymer shall be carefully treated with a thin film of suitable silicone release agent and then conditioned in the environmental cabinet as described in 4.5 for 24 hours to reach the test temperature. The temperature shall be measured by the thermocouple as described in 4.3. The transducers as described in 4.2 shall be set at mid-stroke and the sliding ends clamped in this position whilst the filling of the mould with the polymer takes place. A small fillet of silicone is applied at the junction of the sliding end and the trough to prevent any leakage of the polymer.

4.4 Preparation of specimens

The proportioning and mixing of the polymer shall be carried out in accordance with the manufacturer's instructions. The mixed material shall be carefully placed in the mould and compacted to form a uniform level layer maximum 10 mm deep.

SIST EN 12617-3:2002

4.5 Measurement of shrinkage and expansion

<https://standards.iteh.ai/catalog/standards/sist/958e1300-648f-47c4-a6cc-730839c65161/sist-en-12617-3-2002>

As soon as the specimen preparation is complete the sliding ends are unclamped and initial readings on the transducers and the thermocouples are taken. Record the readings for the sliding end displacement and mould temperature at 5 minutes intervals until 1 hour after the initial gelation of the polymer has taken place (gelation can normally be detected by monitoring the inward movement of the ends). Record further readings at 15 minutes intervals during the next 23 hours and at hourly intervals for the subsequent 24 hours. On completion of the test measure and record the length of the hardened test specimen L_s and the length of the mould between the centre lines of the transducer bases L_m to the nearest 0,1 mm.

Owing to the exothermic nature of the hardening of polymers the temperature of the test specimen and trough will rise to a maximum and the trough will expand thus exaggerating the degree of shrinkage at this stage. Corrections can be made for this expansion but are not usually required as the trough returns to ambient temperature by the time maximum shrinkage has occurred. However, corrections need to be made if a continuous readout of shrinkage is required.

5 Calculation of shrinkage

Calculate the change in length of each specimen, ΔL_s , from the equation.

$$\Delta L_s = \delta_1 + \delta_2 - \delta_3 \quad (1)$$

where

δ_1 and δ_2 are the two transducer readings at either end of the specimen (in mm) (positive towards the centre of the specimen);

EN 12617-3:2002 (E)

δ_3 is the thermal expansion of the mould given by:

$$\delta_3 = L_m \Delta T \alpha_s \quad (2)$$

where

L_m is the length of the mould between transducer fixings (in mm);

ΔT is the change in temperature of the mould from ambient to the prescribed temperature (in K) (values less than 5 K can be ignored);

α_s is the coefficient of thermal expansion of steel ($11 \times 10^{-6} K^{-1}$).

Then calculate the shrinkage strain, S_m , as a percentage, from the equation:

$$S_m = \frac{\Delta L_s}{L_s} \times 100 \quad (3)$$

where

L_s is the effective length of the hardened specimen at the ambient temperature (in mm).

NOTE The method does not distinguish precisely between movements due to thermal expansion of the material and shrinkage of the material at any particular moment of time.

iTech STANDARD PREVIEW
(standards.itech.ai)

6 Test report

SIST EN 12617-3:2002

[https://standards.itech.ai/catalog/standards/sist/958e1300-648f-47c4-a6cc-](https://standards.itech.ai/catalog/standards/sist/958e1300-648f-47c4-a6cc-730829-15861/sist-en-12617-3-2002)

730829-15861/sist-en-12617-3-2002

The following information shall be included in the test report:

- a) reference to this European Standard;
- b) name and address of the test laboratory;
- c) identification number and date of the test report;
- d) name and address of the manufacturer or supplier of the product;
- e) name and identification marks or batch number of the product;
- f) date of supply of the product;
- g) date of preparation of the test specimens and any deviation from the prescribed method of preparation;
- h) conditions of storage of prepared specimens prior to test;
- i) date of test and details of the test equipment used, including the make, type and capacity and the calibrations details or the identification number of the apparatus;
- j) tabulation of the results of shrinkage against time, specifying whether or not temperature correction has been applied, and natural scale graphs of these results;
- k) the time intervals from mixing the constituents to identification of initial gel;
- l) the calculated maximum value of shrinkage strain and the time to reach the value from completion of mixing the constituents for each specimen and their mean values;

- m) precision data;
- n) date of test report and signature.

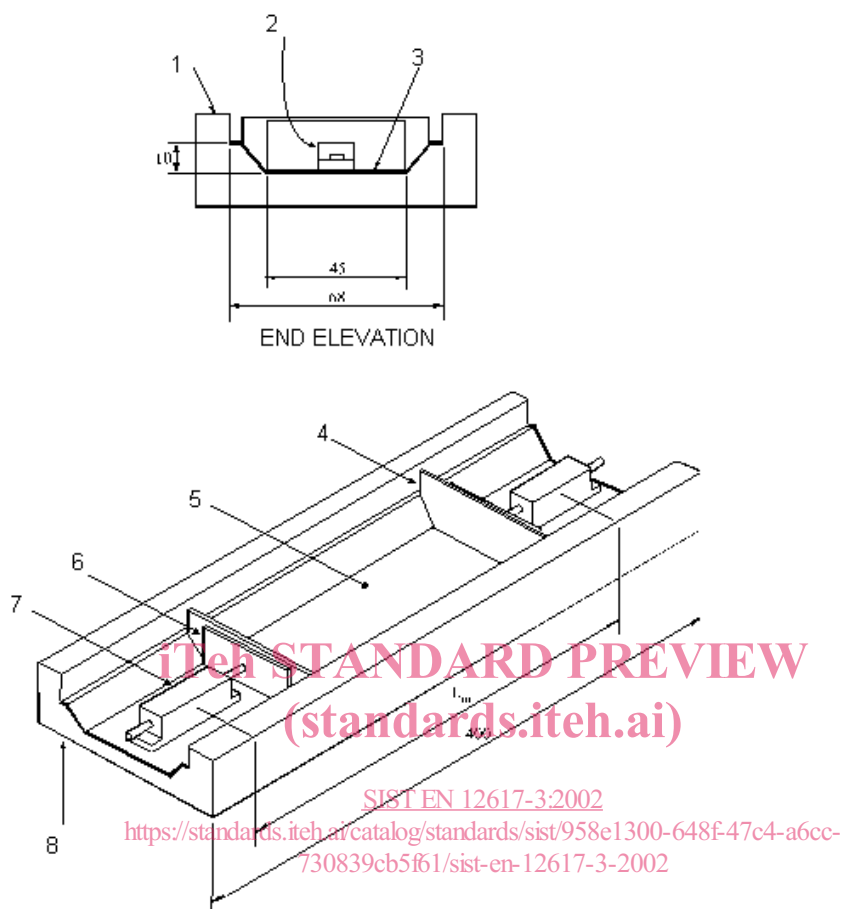

Dimensions in millimetres – Tolerance $\pm 0,1$ mm

Key

- 1 Insulating base
- 2 Displacement transducer
- 3 Steel trough with PTFE lining
- 4 Disposable liner to sliding end
- 5 Pressed steel trough
- 6 Sliding end fixed to transducer spindle
- 7 Transducer
- 8 Insulating base

Figure 1 – General arrangement of steel mould and transducers for measuring displacement and typical cross section