



Designation: E 1823 – 96 (Reapproved 2002)

Standard Terminology Relating to Fatigue and Fracture Testing¹

This standard is issued under the fixed designation E 1823; the number immediately following the designation indicates the year of original adoption or, in the case of revision, the year of last revision. A number in parentheses indicates the year of last approval. A superscript epsilon (ϵ) indicates an editorial change since the last revision or reapproval.

1. Scope

1.1 This terminology contains definitions, definitions of terms specific to certain standards, symbols, and abbreviations approved for use in standards on fatigue and fracture testing. The definitions are preceded by two lists. The first is an alphabetical listing of symbols used. (Greek symbols are listed in accordance with their spelling in English.) The second is an alphabetical listing of relevant abbreviations.

1.2 This terminology includes Annex A1 on Units and Annex A2 on Designation Codes for Specimen Configuration, Applied Loading, and Crack or Notch Orientation.

2. Referenced Documents

2.1 ASTM Standards:

- E 6 Terminology Relating to Methods of Mechanical Testing²
- E 338 Test Method for Sharp-Notch Tension Testing of High-Strength Sheet Materials²
- E 399 Test Method for Plane-Strain Fracture Toughness of Metallic Materials²
- E 436 Test Method for Drop-Weight Tear Tests of Ferritic Steels²
- E 466 Practice for Conducting Force-Controlled Constant Amplitude Axial Fatigue Tests of Metallic Materials²
- E 467 Practice for Verification of Constant Amplitude Dynamic Forces in an Axial Load Fatigue Testing System²
- E 468 Practice for Presentation of Constant Amplitude Fatigue Test Results for Metallic Materials²
- E 561 Practice for R-Curve Determination²
- E 602 Test Method for Sharp-Notch Tension Testing with Cylindrical Specimens²
- E 604 Test Method for Dynamic Tear Testing of Metallic Materials²
- E 606 Practice for Strain-Controlled Fatigue Testing²
- E 647 Test Method for Measurement of Fatigue Crack Growth Rates²
- E 739 Practice for Statistical Analysis of Linear or Linearized Stress-Life (S-N) and Strain-Life (ϵ -N) Fatigue Data²

- E 740 Practice for Fracture Testing with Surface-Crack Tension Specimens²
- E 812 Test Method for Crack Strength of Slow-Bend Pre-cracked Charpy Specimens of High-Strength Metallic Materials²
- E 813 Test Method for J_{Ic} , a Measure of Fracture Toughness³
- E 992 Practice for Determination of Fracture Toughness of Steels Using Equivalent Energy Methodology⁴
- E 1049 Practices for Cycle Counting in Fatigue Analysis²
- E 1152 Test Method for Determining J - R Curves³
- E 1221 Test Method for Determining Plane-Strain Crack-Arrest Fracture Toughness, K_{Ia} , of Ferritic Steels²
- E 1290 Test Method for Crack-Tip Opening Displacement (CTOD) Fracture Toughness Measurement²
- E 1304 Test Method for Plane-Strain (Chevron-Notch) Fracture Toughness of Metallic Materials²
- E 1457 Test Method for Measurement of Creep Crack Growth Rates in Metals²
- E 1681 Test Method for Determining a Threshold Stress Intensity Factor for Environment-Assisted Cracking of Metallic Materials Under Constant Load²
- E 1737 Test Method for J -Integral Characterization of Fracture Toughness⁵
- E 1820 Test Method for Measurement of Fracture Toughness²
- G 15 Terminology Relating to Corrosion and Corrosion Testing⁶

3. Terminology

3.1 Alphabetical Listing of Principal Symbols Used in This Terminology:

Symbol	Term
a	crack depth, crack length, crack size, estimated crack size
a_e	effective crack size
a_n	notch length
a_o	original crack size

¹ This terminology is under the jurisdiction of ASTM Committee E08 on Fatigue and Fracture and is the direct responsibility of Subcommittee E08.02 on Standards and Terminology.

Current edition approved Oct. 10, 2002. Published April 2003. Originally approved in 1996. Last previous edition approved in 1996 as E 1823 – 96.

² Annual Book of ASTM Standards, Vol 03.01.

³ Discontinued. Replaced by E 1737. See 1996 Annual Book of ASTM Standards, Vol 03.01.

⁴ Discontinued. See 1996 Annual Book of ASTM Standards, Vol 03.01.

⁵ Discontinued. Replaced by E 1820. See 1997 Annual Book of ASTM Standards, Vol 03.01.

⁶ Annual Book of ASTM Standards, Vol 03.02.

Symbol	Term
a_p	physical crack size
a/W	normalized crack size
A	load ratio (P_a/P_m)
A_N	net-section area
b	remaining ligament
b_o	original uncracked ligament
B	specimen thickness
B_e	effective thickness
B_N	net thickness
$2c$	surface-crack length
C	normalized K -gradient
D	cycle ratio (n/N_f)
$C^*(t)$	$C^*(t)$ – Integral
da/dN	fatigue-crack-growth rate
δ	crack-tip opening displacement (CTOD)
δd	specimen gage length
Δa	crack extension, estimated crack extension
ΔK	stress-intensity-factor range
ΔK_{th}	fatigue-crack-growth threshold
ΔP	load range
ϵ_a	strain amplitude
ϵ_{in}	inelastic strain
ϵ_m	mean load
G	crack-extension force
G_R	crack-extension resistance
H^*	specimen center of pin hole distance
Γ	the path of the J -integral
J	J -integral
J_{Ic}	plane-strain fracture toughness
J_R	crack-extension resistance
k_f	fatigue notch factor
k_t	theoretical stress concentration factor (sometimes abbreviated stress concentration factor)
$K, K_1, K_2, K_3,$ K_I, K_{II}, K_{III}	stress-intensity factor (see mode)
K_a	crack-arrest fracture toughness
K_c	plane-stress fracture toughness
K_{EAC}	stress intensity factor threshold for environment-assisted cracking
K_{Ia}	plane-strain crack-arrest fracture toughness
K_{IEAC}	stress intensity factor threshold for plane strain environment-assisted cracking
K_{Ic}	plane-strain fracture toughness
K_{IVM}, K_{IV}, K_{IVj}	plane-strain (chevron-notch) fracture toughness
K_{max}	maximum stress-intensity factor
K_{min}	minimum stress-intensity factor
K_o	stress-intensity factor at crack initiation
K_R	crack-extension resistance
n	cycles endured
N_f	fatigue life
P	load
P_a	load amplitude
P_m	mean load
P_M	precrack load
P_{max}	maximum load
P_{min}	minimum load
q	fatigue notch sensitivity
r	effective unloading slope ratio
r_c	critical slope ratio
r_y	plastic-zone adjustment
R	load ratio (P_{min}/P_{max})
s	sample standard deviation
s^2	sample variance
S	specimen span
S_a	load amplitude
S_f	fatigue limit
S_m	mean load
S_N	fatigue strength at N cycles
σ_c	crack strength
σ_N	nominal (net-section) stress
σ_r	residual strength
σ_s	sharp-notch strength
σ_{TS}	tensile strength
$\sigma_x, \sigma_y, \sigma_z$	normal stresses (refer to)
σ_Y	effective yield strength
σ_{YS}	yield strength

Symbol	Term
T	specimen temperature
t_T	transition time
τ_t	total cycle period
$\tau_{xy}, \tau_{yz}, \tau_{zx}$	shear stresses (refer to Fig. 1)
u	displacement in x direction
v	displacement in y direction
$2V_m$	crack-mouth opening displacement
V_c	load-line displacement due to creep
w	displacement in z direction
W	specimen width
Y^*	stress-intensity factor coefficient
Y_m^*	minimum stress-intensity factor coefficient

3.2 Alphabetical Listing of Abbreviations Used:

$CMOD$	crack-mouth opening displacement
COD	see $CTOD$
$CTOD$	crack-tip opening displacement
DT	dynamic tear
$DWTT$	drop-weight tear test
EAC	environment-assisted cracking
$K-EE$	equivalent-energy fracture toughness
NTS	notch tensile strength
PS	part-through surface
SCC	stress corrosion cracking
SZW	stretch zone width

3.3 Definitions—Each definition is followed by the designation(s) of the standard(s) of origin. The listing of definitions is alphabetical.

alternating load—See **loading amplitude**.

block—in *fatigue loading*, a specified number of constant amplitude loading cycles applied consecutively, or a spectrum loading sequence of finite length that is repeated identically. **E 1823**

blunting line—in *fracture testing*, a line that approximates apparent crack advance due to crack-tip blunting in the absence of slow stable crack tearing. The line is defined based on the assumption that the crack advance is equal to one half of the crack-tip opening displacement. This estimate of pseudo-crack advance, Δa_B , is based on the effective yield strength of the material tested. **E 813**

$$\Delta a_B = J/2 \sigma_Y \quad (1)$$

circulation rate [$L^3 T^{-1}$]—in *fatigue testing*, the volume rate of change of the environment chamber volume. **E 1823**

clipping—in *fatigue spectrum loading*, the process of decreasing or increasing the magnitude of all loads (strains) that are, respectively, above or below a specified level, referred to as clipping level; the loads (strains) are decreased or increased to the clipping level (see Fig. 2). **E 1823**

compliance (LF^{-1}), n — the ratio of displacement increment to load increment. **E 1820**

confidence interval—an interval estimate of a population parameter computed so that the statement "the population parameter included in this interval" will be true, on the average, in a stated proportion of the times such computations are made based on different samples from the population. **E 1823**

confidence level (or coefficient)—the stated proportion of the times the confidence interval is expected to include the population parameter. **E 1823**

confidence limits—the two statistics that define a confidence interval. **E 1823**

constant amplitude loading— in *fatigue loading*, a loading

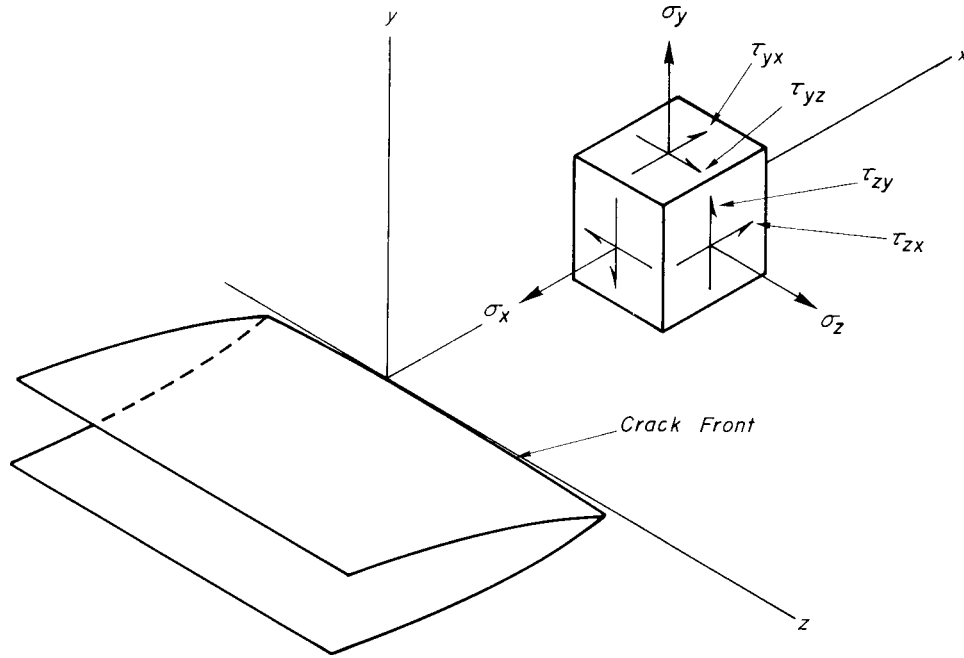

NOTE—See definition of mode.

FIG. 1 Customary Coordinate System and Stress on a Small Volume Element Located on the x Axis Just Ahead of the Crack Front

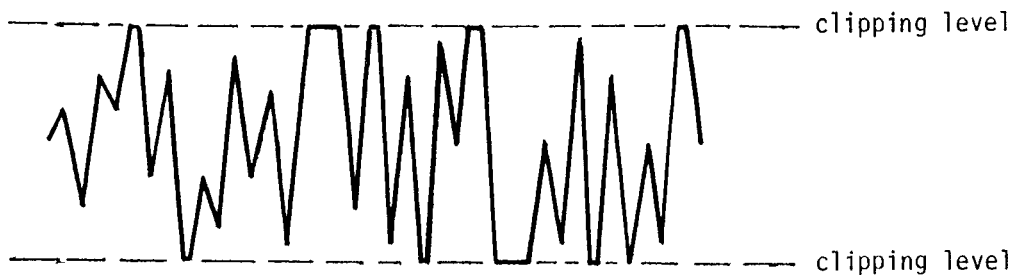

FIG. 2 Clipping of Fatigue Spectrum Loading

(straining) in which all of the peak loads (strains) are equal and all of the valley loads (strains) are equal. **E 1049 constant life diagram**— *in fatigue*, a plot (usually on rectan-

gular coordinates) of a family of curves each of which is for a single fatigue life, N , relating stress amplitude, S_a , to mean stress, S_m , or maximum stress, S_{max} , or both, to minimum

stress, S_{\min} . The constant life fatigue diagram is usually derived from a family of $S-N$ curves each of which represents a different stress ratio (A or R) for a 50 % probability of survival. **E 1823**

corrosion fatigue—the process by which fracture occurs prematurely under conditions of simultaneous corrosion and repeated cyclic loading at lower stress levels or fewer cycles than would be required in the absence of the corrosive environment. **G 15**

counting method—*in fatigue spectrum loading*, a method of counting the occurrences and defining the magnitude of various loading parameters from a load-time history; (some of the counting methods are: level crossing count, peak count, mean crossing peak count, range count, range-pair count, rain-flow count, racetrack count). **E 1049**

crack displacement [L]—the load-induced separation vector between two points (on the facing surfaces of a crack) that were initially coincident.

DISCUSSION—In Practice E 561, displacement is the distance that a chosen measurement point on the specimen displaces normal to the crack plane. Measurement points on the C(W) and C(T) specimen configurations are identified as locations V0, V1, and V2. **E 561**

crack extension, Δa [L]—an increase in crack size.

DISCUSSION—For example, in Practice E 561, Δa_p or Δa_e is the difference between the crack size, either a_p (physical crack size) or a_e (effective crack size), and a_o (original crack size). **E 561**

crack-extension force, G [FL^{-1} or FLL^{-2}]—the elastic energy per unit of new separation area that is made available at the front of an ideal crack in an elastic solid during a virtual increment of forward crack extension.

DISCUSSION—This force concept implies an analytical model for which the stress-strain relations are regarded as elastic. The preceding definition of G applies to either static cracks or running cracks. From past usage, G is commonly associated with linear-elastic methods of analysis, although the J (see **J-integral**) also may be used for such analyses. **E 1823**

crack-extension resistance, K_R [$\text{FL}^{-3/2}$], G_R [FL^{-1}] or J_R [FL^{-1}]—a measure of the resistance of a material to crack extension expressed in terms of the stress-intensity factor, K ; crack-extension force, G ; or values of J derived using the J -integral concept.

DISCUSSION—See definition of R -curve. **E 561**

crack length, a [L]—See crack size and surface crack length. Also see crack length in the *Description of Terms*. For example, in the C(T) specimen, a is measured from the line connecting the bearing points of load application; in the M(T) specimen, a is measured from the perpendicular bisector of the central crack. **E 647**

crack-mouth opening displacement (CMOD), $2v_m$ [L]—the Mode I (also called opening-mode) component of crack displacement resulting from the total deformation (elastic plus plastic), measured under load at the location on a crack surface that has the greatest elastic displacement per unit load.

DISCUSSION—In part-through surface-crack (PS) specimens, $CMOD$

is measured on the specimen surface at the midpoint of the crack length. **E 740**

crack-plane orientation—an identification of the plane and direction of a fracture in relation to product configuration. This identification is designated by a hyphenated code with the first letter(s) representing the direction normal to the crack plane and the second letter(s) designating the expected direction of crack propagation.

DISCUSSION—See also Annex A2, (A2.4 on crack or notch orientation). **E 399**

crack size, a [L]—a lineal measure of a principal planar dimension of a crack. This measure is commonly used in the calculation of quantities descriptive of the stress and displacement fields and is often also termed crack length or depth.

DISCUSSION—In practice, the value of a is obtained from procedures for measurement of physical crack size, a_p , original crack size, a_o , and effective crack size, a_e , as appropriate to the situation being considered. **E 647**

crack strength, σ_c [FL^{-2}]—the maximum value of the nominal stress that a cracked structure is capable of sustaining.

DISCUSSION—1 Crack strength is calculated on the basis of the maximum load and the original minimum cross-sectional area (net cross section or ligament). Thus, it takes into account the original size of the crack but ignores any crack extension that may occur during the test.

DISCUSSION—2 Crack strength is analogous to the ultimate tensile strength, as it is based on the ratio of the maximum load to the minimum cross-sectional area at the start of the test. **E 338, E 602**

crack-tip opening displacement (CTOD), δ , [L]—the crack displacement resulting from the total deformation (elastic plus plastic) at variously defined locations near the original (prior to load application) crack tip.

DISCUSSION—In common practice, δ is estimated for Mode I by inference from observations of crack displacement nearby or away, or both, from the crack tip. **E 1290**

crack-tip plane strain—a stress-strain field (near the crack tip) that approaches plane strain to the degree required by an empirical criterion.

DISCUSSION—For example, in Mode I, the criterion for crack-tip plane strain given by Test Method E 399 requires that plate thickness, B , must be equal to or greater than $2.5 (K/\sigma_{YS})^2$. **E 399**

crack-tip plane stress—a stress-strain field (near the crack tip) that is not in plane strain.

DISCUSSION—In such situations, a significant degree of plane strain may be present. **E 1823**

criterion of failure—complete separation, or the presence of a crack of specified length visible at a specified magnification. Other criteria may be used but should be clearly defined. **E 468**

crystallographic cleavage—the separation of a crystal along a plane of fixed orientation relative to the three-dimensional crystal structure within which the separation process occurs, with the separation process causing the newly formed

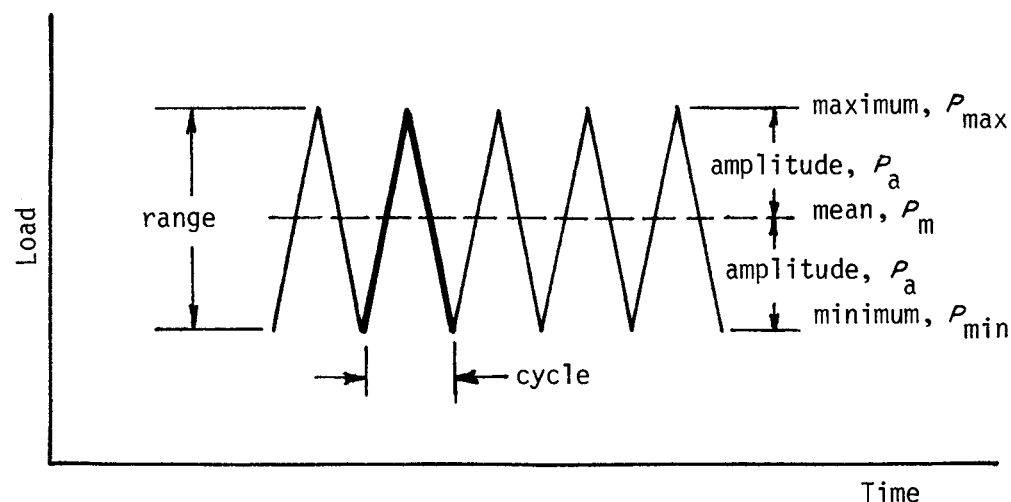

(a) Constant Amplitude Loading

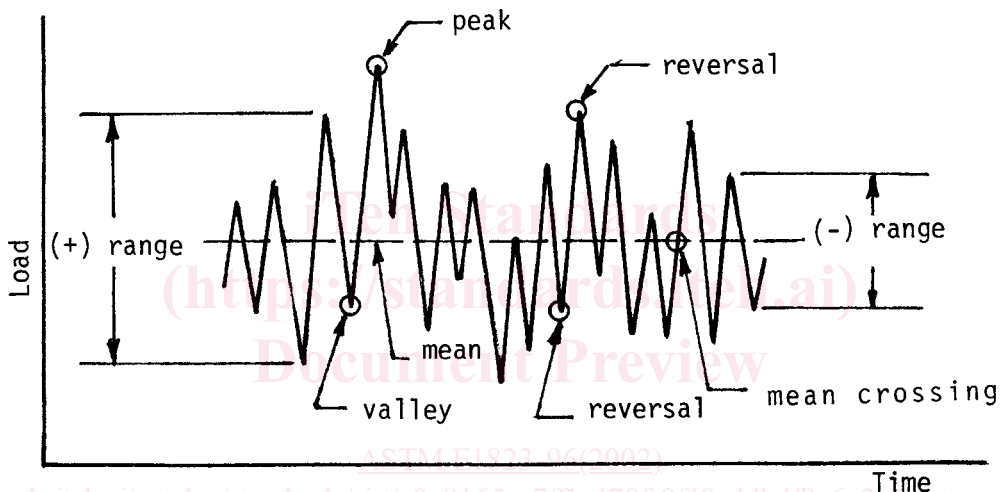

(b) Spectrum Loading

FIG. 3 Fatigue Loading Basic Terms

surfaces to move away from one another in directions containing major components of motion perpendicular to the fixed plane.

E 1823

cumulative frequency spectrum—See **exceedances spectrum**.

cumulative occurrences spectrum—See **exceedances spectrum**.

cycle—*in fatigue*, one complete sequence of values of load (strain) that is repeated under constant amplitude loading (straining). (See Fig. 3.) The symbol N (see definition of **fatigue life**) is used to indicate the number of cycles.

DISCUSSION—In *spectrum loading*, definition of cycle varies with the counting method.

E 1823

cycle ratio, D —the ratio of cycles endured, n , to the estimated fatigue life, N_f , obtained from the stress versus fatigue life ($S-N$) or the strain versus fatigue life ($\epsilon-N$) diagram for cycles of the same character, that is, $D = n/N_f$.

E 1823

cycles endured, n —*in fatigue*, the number of cycles of specified character (that produce fluctuating load) which a

specimen has endured at any time in its load history.

E 1823

cyclic loading—See **fatigue loading**.

deaeration—*in environmentally affected fatigue testing*, the process of removal of air from the liquid environment before and during a test.

E 1823

dynamometer—an elastic calibration device used to verify the indicated loads applied by a fatigue testing system. It shall consist of an instrumented member having mass, stiffness, and end displacements such that the inertial effects of the specimen and its attachments to the testing machine for which the verification of loads is desired are duplicated within 5%. The instrumentation shall permit an accurate determination of the magnitude of the average strain in a region of the uniform transverse cross section when the dynamometer is subjected to a tensile or compressive force along its longitudinal axis, within 1% of the true strains. A

strain gaged specimen is often used as a dynamometer.

E 467

dynamometer dynamic loads [F]—the maximum and minimum loads (or the mean load and the load amplitude) that correspond to the readings obtained from the dynamometer output according to an existing static calibration. Such loads are considered true specimen dynamic loads for the purpose of this terminology.

E 467

dynamometer range [F]—the range of loads for which the dynamometer may be used for verification purposes. A dynamometer for use in tension and in compression will have two dynamometer ranges, one in tension and one in compression.

E 467

effective crack size, a_e [L]—the physical crack size augmented to account for crack-tip plastic deformation.

DISCUSSION—Sometimes the effective crack size, a_e , is calculated from a measured value of a physical crack size, a_p , plus a calculated value of a plastic-zone adjustment, r_Y . Another method for calculation of a_e involves comparing the compliance from the secant of a load-deflection trace with the elastic compliance from a calibration for the given specimen design.

E 561

effective thickness B_e [L]—for compliance-based extension measurements:

E 813

$$B_e = B - (B - B_N)^2 / B \quad (2)$$

effective yield strength, σ_Y [FL⁻²]—an assumed value of uniaxial yield strength, that represents the influences of plastic yielding upon fracture test parameters.

DISCUSSION—1 It is calculated as the average of the 0.2 % offset yield strength, σ_{YS} , and the ultimate tensile strength, σ_{TS} , for example:

$$\sigma_Y = (\sigma_{YS} + \sigma_{TS}) / 2 \quad (3)$$

DISCUSSION—2 In estimating σ_Y , influences of testing conditions, such as loading rate and temperature, should be considered.

E 1823

environment—*in fatigue testing*, the aggregate of chemical species and energy that surrounds a test specimen.

E 1823

environment chamber—*in fatigue testing*, the container of the bulk volume surrounding a test specimen.

E 1823

environment chamber volume [L³]—*in fatigue testing*, that bulk volume surrounding a test specimen.

E 1823

environment composition [ML⁻³]—*in corrosion fatigue testing*, the concentration of the chemical components in the fluid environment surrounding a test specimen.

E 1823

environment hydrogen content [ML⁻³]—*in corrosion fatigue testing*, the hydrogen gas concentration of the fluid environment surrounding a test specimen.

E 1823

environment monitoring—*in fatigue testing*, the periodic or continuous measurement of fluid concentrations of the environment.

E 1823

environment oxygen content [ML⁻³]—*in corrosion fatigue testing*, the oxygen concentration of the fluid environment surrounding a test specimen.

E 1823

environment pressure [FL⁻²]—*in fatigue testing*, the pressure of the bulk volume surrounding a test specimen.

E 1823

environment temperature—*in fatigue testing*, the temperature of the bulk volume surrounding a test specimen.

E 1823

environment volume [L³]—*in fatigue testing*, the total volume immediately surrounding a test specimen plus that

contained in a circulating reservoir if applicable.

E 1823

estimate—*in statistical analysis*, the particular value or values of a parameter computed by an estimation procedure for a given sample.

E 1823

estimated crack extension, Δa [L]—an increase in estimated crack size ($\Delta a = a - a_{oq}$).

E 1737

estimated crack size a [L]—the distance from a reference plane to the observed crack front developed from measurements of elastic compliance or other methods. The reference plane depends on the specimen form, and it is normally taken to be either the boundary, or a plane containing either the load line or the centerline of a specimen or plate. The reference plane is defined prior to specimen deformation.

E 1737

estimation—*in statistical analysis*, a procedure for making a statistical inference about the numerical values of one or more unknown population parameters from the observed values in a sample.

E 1823

exceedances spectrum—*in fatigue loading*, representation of spectrum loading contents by the number of times specified values of a particular loading parameter (peak, range, and so forth) are equaled or exceeded (also known as *cumulative occurrences* or *cumulative frequency spectrum*).

E 1823

fatigue—the process of progressive localized permanent structural change occurring in a material subjected to conditions that produce fluctuating stresses and strains at some point or points and that may culminate in cracks or complete fracture after a sufficient number of fluctuations.

DISCUSSION—1 In ceramic technology, static tests of considerable duration are called “static fatigue” tests, a type of test referred to as stress-rupture in metal testing.

DISCUSSION—2 Fluctuations may occur both in load and with time (frequency) as in the case of “random vibration.”

E 1823

fatigue-crack-growth rate, da/dN , [L]—the rate of crack extension under fatigue loading, expressed in terms of crack extension per cycle of fatigue.

E 1823

fatigue cycle—See **cycle**.

fatigue life, N_f —the number of cycles of a specified character that a given specimen sustains before failure of a specified nature occurs. Fatigue life, or the logarithm of fatigue life, is a dependent variable.

E 1823

fatigue life for p % survival—an estimate of the fatigue life that p % of the population would attain or exceed under a given loading. The observed value of the median fatigue life estimates the fatigue life for 50 % survival. Fatigue life for p % survival values, where p is any number, such as, 95, 90, and so forth, also may be estimated from the individual fatigue life values.

E 1823

fatigue limit, S_f [FL⁻²]—the limiting value of the median fatigue strength as the fatigue life, N_f , becomes very large.

DISCUSSION—Certain materials and environments preclude the attainment of a fatigue limit. Values tabulated as “fatigue limits” in the literature are frequently (but not always) values of S_N for which 50 % of the specimens survive a predetermined number of cycles. These specimens are frequently tested at a mean stress of zero.

E 1823

fatigue limit for p % survival [FL⁻²]—the limiting value of fatigue strength for p % survival as N becomes very large; p

may be any number, such as 95, 90, and so forth. **E 1823**
fatigue loading—periodic, or not periodic, fluctuating loading applied to a test specimen or experienced by a structure in service. (Also known as *cyclic loading*.) **E 1823**

fatigue notch factor, k_f —the ratio of the fatigue strength of a specimen with no stress concentration to a specimen with a stress concentration for the same percent survival at N cycles and for the same conditions. **E 1823**

DISCUSSION—1 In specifying k_f , it is necessary to specify the geometry and the values of S_a , S_m , and N for which it is computed.

DISCUSSION—2 k_f was originally termed the fatigue limit (endurance limit) reduction factor. Early data pertained almost exclusively to mild steels, namely, to $S_a - N$ curves with knees. Later the term was generalized to fatigue strength reduction factor; but, nevertheless, the k_f values tabulated in the literature still pertain almost exclusively to very long (“infinite”) fatigue lives where the notched and unnotched $S_a - N$ curves were almost parallel and almost horizontal. Otherwise, the k_f data are not consistent and are markedly dependent on the type of notch, the fatigue life of interest, and the value of the mean stress.

DISCUSSION—3 Virtually no k_f data exist for percentiles other than (approximately) 50%. Nevertheless, k_f is highly dependent on the percentile of interest. **E 1823**

fatigue notch sensitivity, q —a measure of the degree of agreement between fatigue notch factor, k_f , and theoretical stress concentration factor, k_t .

DISCUSSION—1 The definition of fatigue notch sensitivity is $q = (k_f - 1)/(k_t - 1)$.

DISCUSSION—2 q was originally termed the fatigue notch sensitivity index.

DISCUSSION—3 Virtually all q data and q curves found in the literature pertain to very long (“infinite”) fatigue lives where the notched and unnotched $S_a - N$ curves are almost parallel and almost horizontal, as well as to tests in which $S_m = 0$. Thus, these values should not be extrapolated to $S_m \neq 0$ or “finite” life situations.

DISCUSSION—4 Fatigue notch sensitivity is not considered to be a material property. **E 1823**

fatigue strength at N cycles, S_N [FL^{-2}]—a value of stress for failure at exactly N cycles as determined from an $S - N$ diagram. The value of S_N thus determined is subject to the same conditions as those which apply to the $S - N$ diagram.

DISCUSSION—The value of S_N that is commonly found in the literature is the value of S_{\max} or S_a at which 50% of the specimens of a given sample could survive N stress cycles in which $S_m = 0$. This is also known as the median fatigue strength for N cycles. **E 1823**

fatigue strength for p % survival at N cycles [FL^{-2}]—an estimate of the stress level at which p % of the population would survive N cycles; p may be any percent, such as 95, 90, and so forth.

DISCUSSION—ASTM STP 588⁷ and STP 744⁸ include estimation methods for these values. **E 1823**

fatigue testing system—a device for applying repeated load cycles to a specimen or component. **E 467**

fracture toughness—a generic term for measures of resistance to extension of a crack.

DISCUSSION—The term is sometimes restricted to results of fracture mechanics tests, which are directly applicable in fracture control. However, the term commonly includes results from tests of notched or precracked specimens which do not involve fracture mechanics analysis. Results from tests of the latter type are often useful for fracture control, based upon either service experience or empirical correlations with tests analyzed using fracture mechanics. **E 740**

frequency distribution—the way in which the frequencies of occurrence of members of a population, or a sample, are distributed in accordance with the values of the variable under consideration. **E 1823**

group—*in fatigue*, specimens of the same type tested at a specific time, or consecutively, at one stress level. A group may comprise one or more specimens. **E 1823**

hold time [T]—*in fatigue testing*, the amount of time in the cycle where the controlled test variable (for example, load, strain, displacement) remains constant with time. (See Fig. 4.) **E 606**

hysteresis diagram—*in fatigue*, the stress-strain path during a cycle. **E 1823**

ideal crack—a simplified model of a crack. In a stress-free body, the crack has two smooth surfaces that are coincident and join within the body along a smooth curve called the crack front; in two-dimensional representations the crack front is called the crack tip. **E 1823**

ideal-crack-tip stress field—the singular stress field, infinitesimally close to the crack front, that results from loading an ideal crack. In a linear-elastic homogeneous body, the significant stress components vary inversely as the square root of the distance from the crack tip.

DISCUSSION—In a linear-elastic body, the crack-tip stress field can be regarded as the superposition of three component stress fields called modes. **E 1823**

independent variable—the selected and controlled variable (namely, stress or strain). It is denoted X when plotted on appropriate coordinates. **E 739**

indicated dynamic loads [F]—the maximum and minimum loads (or the mean load and the load amplitude) that correspond to the readings obtained from the load cell associated with the fatigue testing system, according to an existing static calibration. The load cell calibration may have been furnished by the machine manufacturer or may have been developed by the user. **E 467**

inelastic strain, ϵ_{in} —the strain that is not elastic.

DISCUSSION—For isothermal conditions, ϵ_{in} is calculated by subtracting the elastic strain from the total strain. **E 606**

interval estimate—the estimate of a parameter given by two statistics, defining the end points of an interval. **E 1823**

irregularity factor—*in fatigue loading*, the ratio of the number of zero crossings with positive slope (or mean crossings) to the number of peaks or valleys in a given, load-time history. **E 1823**

irregular loading— See **spectrum loading**.

J-integral, J [FL^{-1}]—a mathematical expression, a line or surface integral that encloses the crack front from one crack surface to the other, used to characterize the local stress-strain field around the crack front.

⁷ *Manual on Statistical Planning and Analysis, ASTM STP 588*, ASTM, 1975.

⁸ *Statistical Analysis of Fatigue Data, ASTM STP 744*, ASTM, 1979.

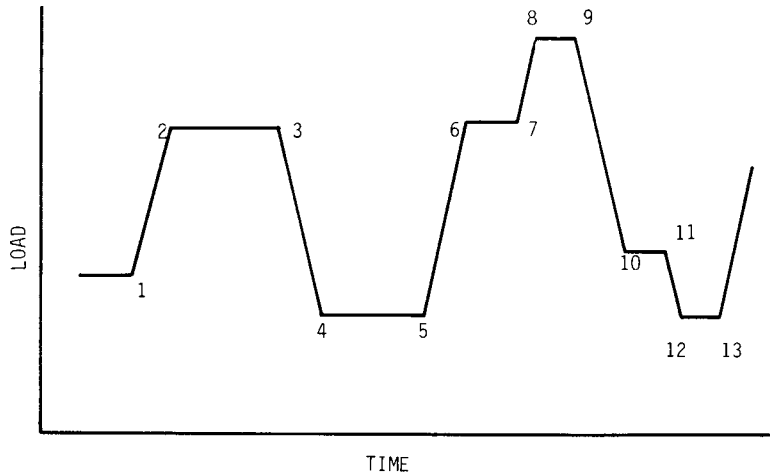

Examples of Definitions
 Hold Times: 2-3, 4-5, 6-7, 8-9, 10-11, 12-13
 Peaks: 2-3, 8-9
 Valleys: 4-5, 12-13
 Reversals: 3, 5, 9, 13

FIG. 4 Definitions of Terms for Load-Histories with Hold Times

DISCUSSION—1 The J -integral expression for a two-dimensional crack, in the x - z plane with the crack front parallel to the z axis, is the line integral,

$$J = \int_{\Gamma} \left(W dy - T \frac{\partial u}{\partial x} ds \right) \quad (4)$$

where:

- W = loading work per unit volume or, for elastic bodies, strain energy density,
- Γ = path of the integral, that encloses (that is, contains) the crack tip (see Fig. 5),
- ds = increment of the contour path,
- T = outward traction vector on ds ,
- u = displacement vector at ds ,
- x, y, z = rectangular coordinates (see Fig. 1), and
- $T \frac{\partial u}{\partial x} ds$ = rate of work input from the stress field into the area enclosed by Γ .

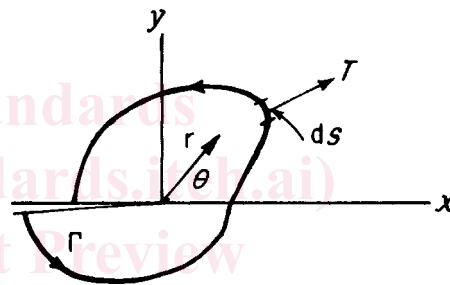

FIG. 5 J-Integral Contour and Symbolism

J -integral against physical crack extension Δa_p . **E 813**

level crossings—*in fatigue loading*, the number of times that the load-time (strain-time) history crosses a given load (strain) level with a positive slope or a negative slope, or both, as specified during a given period. **E 1823**

load, P [F]—the force applied to a test specimen or to a component. **E 1823**

load cell—a device which indicates the applied force by means of an electrical voltage. Usually the electrical voltage increases linearly with applied load. **E 467**

load cycle—See **cycle**.

load range, ΔP [FL⁻²]—*in fatigue loading*, the algebraic difference between successive valley and peak loads (positive range or increasing load range) or between successive peak and valley loads (negative range or decreasing load range). (See Fig. 3.) In constant amplitude loading, the range is given as follows:

$$\Delta P = P_{\max} - P_{\min} \quad (5)$$

DISCUSSION—In cycle counting by various methods, it is common to employ ranges between valley and peak loads, or between peak and valley loads, which are not necessarily successive events. The word “range” is used in this broader sense when dealing with cycle counting.

E 1823

J - R curve—a plot of resistance to stable crack extension, Δa_p .

DISCUSSION—In Test Method E 813, the J - R curve is a plot of the

⁹ For further discussion, see Rice, J. R., *Journal of Applied Mechanics*, Vol 35, 1968, p. 379.

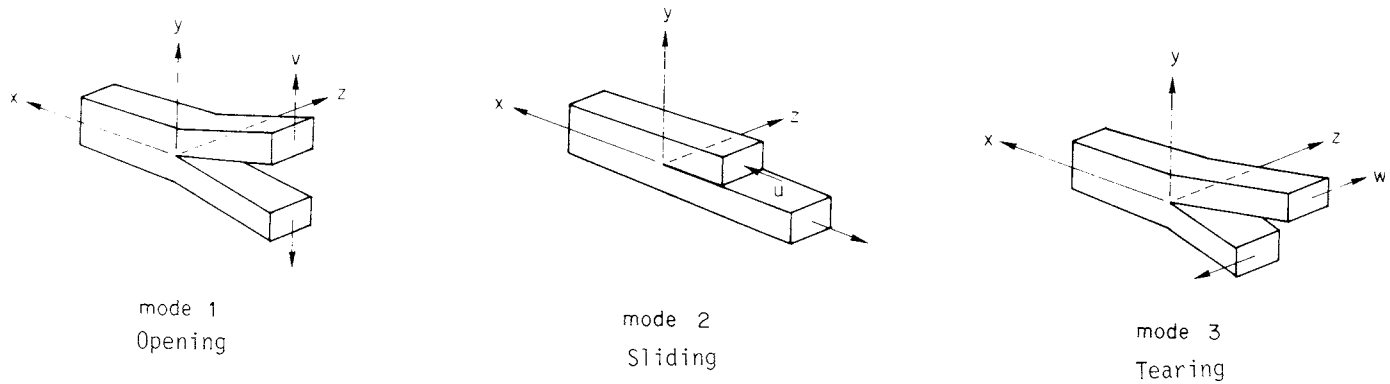

NOTE—See definition of mode.

FIG. 6 Basic Modes of Crack (Surface) Displacements for Isotropic Materials

load ratio (also stress ratio), R , A —*in fatigue*, the algebraic ratio of the two loading parameters of a cycle. The most widely used ratios are as follows

$$R = \frac{\text{minimum load}}{\text{maximum load}} = \frac{P_{\min}}{P_{\max}} = \frac{S_{\min}}{S_{\max}}, \text{ and} \quad (6)$$

$$A = \frac{\text{loading amplitude}}{\text{mean load}} = \frac{P_a}{P_m} = \frac{S_a}{S_m} \quad (7)$$

E 647

load (strain) amplitude, P_a (S_a or ϵ_a) [**F** or **FL⁻²**]*—in fatigue loading*, one half of the range of a cycle (see Fig. 3) (also known as *alternating load*). E 1823

loading (unloading) rate [**F T⁻¹**]*—the time rate of change in the monotonic increasing (decreasing) portion of the load-time function.* E 1823

log-normal distribution*—the distribution of N when $\log(N)$ is normally distributed. (Accordingly, it is convenient to analyze $\log(N)$ using methods based on the normal distribution.)* E 739

maximum load, P_{\max} [F]*—in fatigue*, the highest algebraic value of applied load in a cycle. By convention, tensile loads are positive and compressive loads are negative. E 647

maximum stress-intensity factor, K_{\max} [FL^{-3/2}]*—in fatigue*, the maximum value of the stress-intensity factor in a cycle. This value corresponds to P_{\max} . E 647

mean crossings*—in fatigue loading*, the number of times that the load-time history crosses the mean load level with a positive slope or a negative slope, or both, as specified during a given period. (See Fig. 3.) E 1049

mean load, P_m (or S_m or ϵ_m) [**F** or **FL²**]*—in fatigue loading*, the algebraic average of the maximum and minimum loads in constant amplitude loading, or of individual cycles in spectrum loading,

$$P_m = \frac{P_{\max} + P_{\min}}{2} \quad (8)$$

or the integral average of the instantaneous load values of a spectrum loading history. E 1049

median fatigue life*—the middle value of the observed fatigue lives, arranged in order of magnitude, of the individual specimens in a group tested under essentially identical conditions. If the sample size is even, it is the average of the two middlemost values.*

DISCUSSION—1 The use of the median instead of the arithmetic mean (that is, the average) is usually preferred.

DISCUSSION—2 In the literature, the abbreviated term “fatigue life” usually has meant the median fatigue life of the group. However, when applied to a collection of data without further qualification, the term “fatigue life” is ambiguous. E 1823

median fatigue strength at N cycles [FL⁻²]*—an estimate of the stress level at which 50 % of the population would survive N cycles.*

DISCUSSION—1 The estimate of the median fatigue strength is derived from a particular point of the fatigue life distribution, since there is no test procedure by which a frequency distribution of fatigue strengths at n cycles can be directly observed.

DISCUSSION—2 This is a special case of the more general definition of fatigue strength for p % survival at N cycles. E 1823

minimum load, P_{\min} [F]*—in fatigue*, the lowest algebraic value of applied load in a cycle. By convention, tensile loads are positive and compressive loads are negative. E 647

minimum stress-intensity factor, K_{\min} [FL^{-3/2}]*—in fatigue*, the minimum value of the stress-intensity factor in a cycle. This value corresponds to P_{\min} when $R > 0$ and is taken to be zero when $R \leq 0$. E 647

mode*—one of the three classes of crack (surface) displacements adjacent to the crack tip. These displacement modes are associated with the stress-strain fields around the crack tip and are designated one, two, and three. Arabic numerals 1, 2, and 3 are used for the general case, and they represent opening, sliding, and tearing displacements, respectively. (See Fig. 6.) Roman numerals are used to specialize the mode to plane strain (I and II) or to antiplane-strain (III).*

DISCUSSION—For isotropic materials, these three modes can be represented by the crack (surface) displacements presented in Table 1 and Fig. 6. For anisotropic materials, displacements can be more complex. Using the coordinates shown in Fig. 1 and assuming a homogeneous, isotropic elastic body, the singular stresses on an infinitesimal element just ahead of the crack front for Modes I, II, and III are zero or non-zero as indicated in Table 1. For linear-elastic bodies, the three stress-strain fields can be added to describe any crack-tip stress-strain field. E 1823

net-section area, A_N [L²]*—area of the net remaining ligament.*

net thickness, B_N [L]*—distance between the roots of the side*

TABLE 1 Stress and Displacement Components^A for Plane-Strain and Anti-Plane-Strain Modes (see Definition of Mode). See Fig. 6.

NOTE—It is recommended that the arabic subscript 1 be omitted except where needed for clarity.

	Mode I	Mode II	Mode III
Crack (surface) displacements ^B just behind the crack front:			
u	0	*	0
v	*	0	0
w	0	0	*
Stresses on the $x - z$ plane just ahead of the crack front (see Fig. 1):			
σ_x	*	0	0
σ_y	*	0	0
σ_z	*	0	0
τ_{xy}	0	*	0
τ_{yz}	0	0	*
τ_{zx}	0	0	0

^A * means non-zero. 0 means zero.

^B Not applicable generally to anisotropic materials.

grooves in side-grooved specimens. **E 813, E 1152**

neutral solution—a fluid environment containing an equal amount of hydrogen and hydroxyl ions, that is, pH = 7.

nominal (net-section) stress, σ_N [FL⁻²]—in fracture testing, a measure of the stress on the net cross section calculated in a simplified manner and without taking into account stress gradients produced by geometric discontinuities such as holes, grooves, fillets, and so forth.

DISCUSSION—1 In tension specimens (tension only), the average stress is used:

$$\sigma_N = P/A_N \quad (9)$$

where:

$A_N = B(W - a)$ for rectangular sections, and

$A_N = (\pi d^2)/4$ for circular sections.

DISCUSSION—2 In bend specimens (bending only), a fiber stress is used:

$$\sigma_N = \frac{6M}{B(W - a)^2} \quad (10)$$

DISCUSSION—3 In compact specimens (tension and bending),

$$\sigma_N = \frac{2P(2W + a)}{B(W - a)^2} \quad (11)$$

DISCUSSION—4 In arc-shaped specimens (tension and bending),

$$\sigma_N = \frac{2P(3X + 2W + a)}{B(W - a)^2} \quad (12)$$

DISCUSSION—5 In Notes 1 to 4:

d = diameter of notched section of a circumferentially notched specimen, m (in.),

P = load, N (lbf),

B = specimen thickness, m (in.),

W = specimen width, m (in.),

a = crack size (length of notch or notch plus precrack), m (in.),

X = loading hole offset, m (in.), and

M = bending moment, Nm (in.-lb).

The result, σ_N , is given in Pa (psi). See Test Method E 399 for further explanations on symbols. **E 399, E 602**

notch tensile strength (NTS) [FL⁻²]—the maximum nominal

(net-section) stress that a notched tensile specimen is capable of sustaining.

DISCUSSION—1 See definitions of nominal (net-section) stress and sharp-notch strength.

DISCUSSION—2 Values of notch tensile strength may depend upon section size, notch sharpness, and the eccentricity of the notch. See **sharp-notch strength. E 1823**

occurrences spectrum—in fatigue loading, representation of spectrum loading contents by the number of times a particular loading parameter (peak, range, and so forth) occurs within each specified loading interval between lower and upper bound values. **E 1823**

original crack size, a_o , [L]—the physical crack size at the start of testing. **E 561, E 740, E 813, E 1152**

original uncracked ligament, b_o , [L]—distance from the original crack front to the back edge of the specimen, that is:

$$b_o = W - a_o \quad (13)$$

parameter—in statistics, a constant (usually to be estimated) defining some property of the population frequency distribution, such as the population median or the population standard deviation. **E 1823**

peak—in fatigue loading, the point where the first derivative of the load-time history changes from positive to negative sign; the point of maximum load in constant amplitude loading (see Fig. 3). For load histories with hold times see Fig. 4. **E 1049**

physical crack extension, Δa_p , [L]—an increase in physical crack size.

$$\Delta a_p = a_p - a_o \quad (14)$$

E 813, E 1152

physical crack size, a_p , [L]—the distance from a reference plane to the observed crack front. This distance may represent an average of several measurements along the crack front. The reference plane depends on the specimen form, and normally is taken to be either the boundary, or a plane containing either the load line or the centerline of a specimen or plate. The reference plane is defined prior to specimen deformation. **E 561, E 813, E 1152**

plane-strain fracture toughness, K_{Ic} [FL^{-3/2}], J_{Ic} [FL⁻¹]—the crack-extension resistance under conditions of crack-tip plane strain.

DISCUSSION—1 For example, in Mode I for slow rates of loading and negligible plastic-zone adjustment, plane-strain fracture toughness is the value of the stress-intensity factor designated K_{Ic} as measured using the operational procedure (and satisfying all of the validity requirements) specified in Test Method E 399, that provides for the measurement of crack-extension resistance at the start of crack extension and provides operational definitions of crack-tip sharpness, start of crack-extension, and crack-tip plane strain.

DISCUSSION—2 For example, in Mode I with slow rates of loading and substantial plastic deformation, plane-strain fracture toughness is the value of the J -integral designated J_{Ic} [FL⁻¹] as measured using the operational procedure (and satisfying all of the validity requirements) specified in Test Method E 813, that provides for the measurement of crack-extension resistance near the onset of stable crack extension.

DISCUSSION— See also **crack-extension resistance, crack-tip plane strain, and mode. E 399**

plastic-zone adjustment, r_Y , [L]—an addition to the physical