



SLOVENSKI STANDARD SIST EN 3372-006:2009

01-julij-2009

5 YfcbUj h_U! ?cbY_lcf jZY_f] b]žc_fc[`]žnUý]hYb]_cbhU_lžn`VU`cbYfb]a
g`Ud`Ub`Ya žghU_bUXY`cj bUH`Ya dYfUhi fUa YX`!*) `š7 `]b`%+) `š7 `U]`&\$\$`š7 `!`\$\$* `XY`.
NUý]fbU`UdUnUXcnc`!`GhUbXUfX`nUdfc]nj`cX

Aerospace series - Connectors, electrical, circular, medium and high contact density, scoop-proof with bayonet coupling, operating temperatures - 65 °C to 175 °C or 200 °C continuous - Part 006: Protective cover for receptacle - Product standard

STANDARD PREVIEW

Luft- und Raumfahrt - Elektrische Rundsteckverbinder, kontaktgeschützt, Bajonettkupplung, Betriebstemperatur - 65 °C bis 175 °C oder 200 °C konstant - Teil 006: Schutzkappe für festen Steckverbinder – Produktnorm

[SIST EN 3372-006:2009](https://standards.iteh.ai/catalog/standards/sist/5f45c44-6b89-44b8-ac6e-30c0c1000000/sist-en-3372-006-2009)

[https://standards.iteh.ai/catalog/standards/sist/5f45c44-6b89-44b8-ac6e-](https://standards.iteh.ai/catalog/standards/sist/5f45c44-6b89-44b8-ac6e-30c0c1000000/sist-en-3372-006-2009)

Série aérospatiale - Connecteurs électriques circulaires scoop-proof à accouplement par baïonnettes température d'utilisation - 65 °C à 175 °C ou 200 °C continu - Partie 006 : Bouchon de vol pour embase - Norme de produit

Ta slovenski standard je istoveten z: EN 3372-006:2007

ICS:

49.060 Š^cp \ aš Ā^• [|b \ æ Aerospace electric
^|\ dā } aš] !^ { aš Ā ā c { ā equipment and systems

SIST EN 3372-006:2009

en,de

iTeh STANDARD PREVIEW
(standards.iteh.ai)

SIST EN 3372-006:2009

<https://standards.iteh.ai/catalog/standards/sist/f5f45c44-6b89-44b8-ac6e-1b36d5817997/sist-en-3372-006-2009>

EUROPEAN STANDARD
NORME EUROPÉENNE
EUROPÄISCHE NORM

EN 3372-006

July 2007

ICS 49.060

English Version

Aerospace series - Connectors, electrical, circular, medium and high contact density, scoop-proof with bayonet coupling, operating temperatures - 65 °C to 175 °C or 200 °C continuous - Part 006: Protective cover for receptacle - Product standard

Série aérospatiale - Connecteurs électriques circulaires scoop-proof à accouplement par baïonnettes, température d'utilisation - 65 °C à 175 °C ou 200 °C continu - Partie 006 : Bouchon de vol pour embase - Norme de produit

Luft- und Raumfahrt - Elektrische Rundsteckverbinder, kontaktgeschützt, Bajonettkupplung, Betriebstemperatur - 65 °C bis 175 °C oder 200 °C konstant - Teil 006: Schutzkappe für festen Steckverbinder - Produktnorm

This European Standard was approved by CEN on 24 June 2006.

CEN members are bound to comply with the CEN/CENELEC Internal Regulations which stipulate the conditions for giving this European Standard the status of a national standard without any alteration. Up-to-date lists and bibliographical references concerning such national standards may be obtained on application to the CEN Management Centre or to any CEN member.

This European Standard exists in three official versions (English, French, German). A version in any other language made by translation under the responsibility of a CEN member into its own language and notified to the CEN Management Centre has the same status as the official versions.

[SIST EN 3372-006:2009](https://standards.iteh.ai/catalog/standards/sist/5e15c41-6b89-44b8-ac6e-d1155072a/Latvia-Lithuania-Luxembourg-Malta-Netherlands-Norway-Poland-Portugal-Romania-Slovakia-Slovenia-Spain-Sweden-Switzerland-and-United-Kingdom)

CEN members are the national standards bodies of Austria, Belgium, Bulgaria, Cyprus, Czech Republic, Denmark, Estonia, Finland, France, Germany, Greece, Hungary, Iceland, Ireland, Italy, Latvia, Lithuania, Luxembourg, Malta, Netherlands, Norway, Poland, Portugal, Romania, Slovakia, Slovenia, Spain, Sweden, Switzerland and United Kingdom.



EUROPEAN COMMITTEE FOR STANDARDIZATION
COMITÉ EUROPÉEN DE NORMALISATION
EUROPÄISCHES KOMITEE FÜR NORMUNG

Management Centre: rue de Stassart, 36 B-1050 Brussels

Contents

Page

Foreword.....	3
1 Scope	4
2 Normative references	4
3 Terms and definitions	4
4 Required characteristics	5
5 Designation	6
6 Marking	7
7 Technical specification	7

iTeh STANDARD PREVIEW
(standards.iteh.ai)

[SIST EN 3372-006:2009](https://standards.iteh.ai/catalog/standards/sist/f5f45c44-6b89-44b8-ac6e-1b36d5817997/sist-en-3372-006-2009)

<https://standards.iteh.ai/catalog/standards/sist/f5f45c44-6b89-44b8-ac6e-1b36d5817997/sist-en-3372-006-2009>

Foreword

This document (EN 3372-006:2007) has been prepared by the Aerospace and Defence Industries Association of Europe - Standardization (ASD-STAN).

After enquiries and votes carried out in accordance with the rules of this Association, this Standard has received the approval of the National Associations and the Official Services of the member countries of ASD, prior to its presentation to CEN.

This European Standard shall be given the status of a national standard, either by publication of an identical text or by endorsement, at the latest by January 2008, and conflicting national standards shall be withdrawn at the latest by January 2008.

According to the CEN/CENELEC Internal Regulations, the national standards organizations of the following countries are bound to implement this European Standard: Austria, Belgium, Belgium, Cyprus, Czech Republic, Denmark, Estonia, Finland, France, Germany, Greece, Hungary, Iceland, Ireland, Italy, Latvia, Lithuania, Luxembourg, Malta, Netherlands, Norway, Poland, Portugal, Romania, Slovakia, Slovenia, Spain, Sweden, Switzerland and the United Kingdom.

iTeh STANDARD PREVIEW (standards.iteh.ai)

[SIST EN 3372-006:2009](https://standards.iteh.ai/catalog/standards/sist/15f45c44-6b89-44b8-ac6e-1b36d5817997/sist-en-3372-006-2009)

<https://standards.iteh.ai/catalog/standards/sist/15f45c44-6b89-44b8-ac6e-1b36d5817997/sist-en-3372-006-2009>

EN 3372-006:2007 (E)

1 Scope

This standard specifies the characteristics of protective covers for receptacles in the family of circular electrical connectors coupled by bayonet ring.

It applies to class defined in Table 2.

For receptacles associated with these protective covers, see EN 3372-003, EN 3372-004, EN 3372-005, EN 3372-009 and EN 3372-010.

2 Normative references

The following referenced documents are indispensable for the application of this document. For dated references, only the edition cited applies. For undated references, the latest edition of the referenced document (including any amendments) applies.

EN 3372-001, *Aerospace series — Connectors, electrical, circular, medium and high contact density, scoop-proof with bayonet coupling, operating temperatures –65 °C to 175 °C or 200 °C continuous — Part 001: Technical specification*

EN 3372-002, *Aerospace series — Connectors, electrical, circular, medium and high contact density, scoop-proof with bayonet coupling, operating temperatures –65 °C to 175 °C or 200 °C continuous — Part 002: Specification of performance and contact arrangements*

EN 3372-003, *Aerospace series — Connectors, electrical, circular, medium and high contact density, scoop-proof with bayonet coupling, operating temperatures –65 °C to 175 °C or 200 °C continuous — Part 003: Square flange receptacle — Product standard*

EN 3372-004, *Aerospace series — Connectors, electrical, circular, medium and high contact density, scoop-proof with bayonet coupling, operating temperatures –65 °C to 175 °C or 200 °C continuous — Part 004: Receptacle, hermetic, Square flange mounting — Product standard¹⁾*

EN 3372-005, *Aerospace series — Connectors, electrical, circular, medium and high contact density, scoop-proof with bayonet coupling, operating temperatures –65 °C to 175 °C or 200 °C continuous — Part 005: Receptacle, hermetic, round flange, solder mounting — Product standard*

EN 3372-009, *Aerospace series — Connectors, electrical, circular, medium and high contact density, scoop-proof with bayonet coupling, operating temperatures –65 °C to 175 °C or 200 °C continuous — Part 009: Receptacle, round flange, jam nut mounting — Product standard*

EN 3372-010, *Aerospace series — Connectors, electrical, circular, medium and high contact density, scoop-proof with bayonet coupling, operating temperatures –65 °C to 175 °C or 200 °C continuous — Part 010: Receptacle, hermetic, round flange, jam nut mounting — Product standard¹⁾*

3 Terms and definitions

For the purposes of this standard, the terms and definitions given in EN 3372-001 apply.

¹⁾ In preparation at the date of the publication of this standard.

4 Required characteristics

4.1 Dimensions, mass

See Figure 1 and Table 1.

Dimensions apply after surface treatment

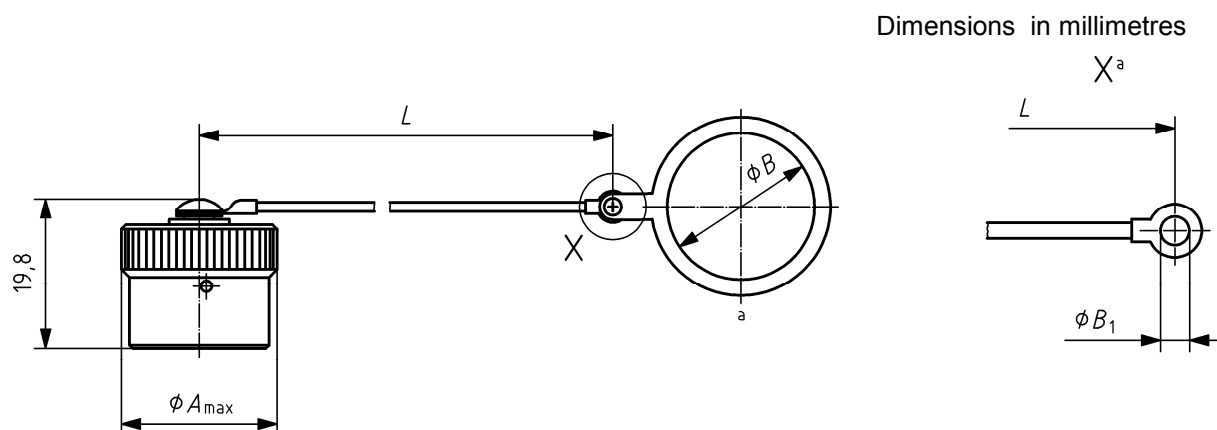

a Style A solid ring.

Figure 1 — Protective cover
Table 1 — Dimensions and mass

Housing size	A mm max.	Attachment length L mm	Solid ring B mm	B_1 mm	Mass g max.
08	18,3	76,2	13,1	4,3	12,0
10	20,6		19,5		13,0
12	25,4	88,9	22,6		17,0
14	28,5		25,8		18,0
16	31,7		29,0		21,0
18	34,9		38,6		22,0
20	38,1	101,6	41,7		26,0
22	41,3				28,0
24	44,5			30,0	

EN 3372-006:2007 (E)**4.2 Material, surface treatment**

See Table 2.

4.3 Main general characteristics

According to EN 3372-002.

4.4 Possible combinations of protective covers and connectors

According to EN 3372-002.

5 Designation

EXAMPLE

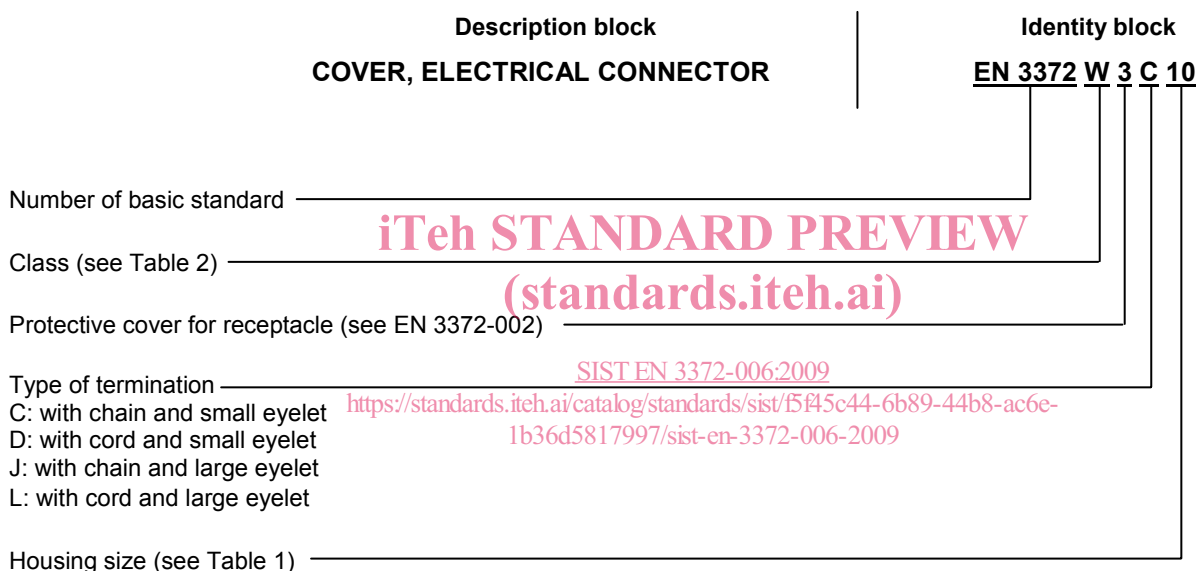

NOTE If necessary, the code I9005 shall be placed between the description block and the identity block.

Table 2 — Protective cover class

Class	Description
W	Cadmium-plated aluminium alloy, olive drab — 500 h salt mist — Maximum operating temperature 175 °C continuous
F	Nickel-plated aluminium alloy — 48 h salt mist — Maximum operating temperature 200 °C continuous