



SLOVENSKI STANDARD SIST EN 3372-008:2009

01-september-2009

5 YfcbUj h_U!?'cbY_lcf{žY_Y_kf] b]žc_fc[`]žnUý]hYb]_cbhU_lžn`VU`cbYfb]a
g_`Ud`Ub^Ya žghUbuXYcj bUHyA dYfUhi fUa YX!*) `š7 `]b`%+) `š7 `U]`&\$\$`š7 `!`\$\$, "XY.
Jh] `!`GHUbXUfX`nUdfc]nj cX

Aerospace series - Connectors, electrical, circular, medium and high contact density, scoop-proof with bayonet coupling, operating temperatures - 65 °C to 175 °C or 200 °C continuous - Part 008: Free plug with grounding spring - Product standard

ITeH STANDARD PREVIEW

Luft- und Raumfahrt - Elektrische Rundsteckverbinder, kontaktgeschützt, Bajonettkupplung, Betriebstemperatur - 65 °C bis 175 °C oder 200 °C konstant - Teil 008: Freier Steckverbinder – Produktnorm

[SIST EN 3372-008:2009](https://standards.iteh.ai/catalog/standards/sist/762efb4b-1c32-493d-8313-)

<https://standards.iteh.ai/catalog/standards/sist/762efb4b-1c32-493d-8313->

Série aérospatiale - Connecteurs électriques circulaires scoop-proof à accouplement par baïonnettes température d'utilisation - 65 °C à 175 °C ou 200 °C continu - Partie 008: Fiche - Norme de produit

Ta slovenski standard je istoveten z: EN 3372-008:2007

ICS:

49.060 Š^cp \ æš Á^•[|b \ æ Aerospace electric
^|\ dã} æ] !^ { æš Á ã c { ã equipment and systems

SIST EN 3372-008:2009

en,de

iTeh STANDARD PREVIEW
(standards.iteh.ai)

SIST EN 3372-008:2009

<https://standards.iteh.ai/catalog/standards/sist/762efb4b-1c32-493d-8313-504f181375e9/sist-en-3372-008-2009>

EUROPEAN STANDARD
NORME EUROPÉENNE
EUROPÄISCHE NORM

EN 3372-008

July 2007

ICS 49.060

English Version

Aerospace series - Connectors, electrical, circular, medium and high contact density, scoop-proof with bayonet coupling, operating temperatures - 65 °C to 175 °C or 200 °C continuous - Part 008: Free plug with grounding spring - Product standard

Série aérospatiale - Connecteurs électriques circulaires scoop-proof à accouplement par baïonnettes, température d'utilisation - 65 °C à 175 °C ou 200 °C continu - Partie 008 : Fiche - Norme de produit

Luft- und Raumfahrt - Elektrische Rundsteckverbinder, kontaktgeschützt, Bajonettkupplung, Betriebstemperatur - 65 °C bis 175 °C oder 200 °C konstant - Teil 008: Freier Steckverbinder - Produktnorm

This European Standard was approved by CEN on 24 June 2006.

CEN members are bound to comply with the CEN/CENELEC Internal Regulations which stipulate the conditions for giving this European Standard the status of a national standard without any alteration. Up-to-date lists and bibliographical references concerning such national standards may be obtained on application to the CEN Management Centre or to any CEN member.

This European Standard exists in three official versions (English, French, German). A version in any other language made by translation under the responsibility of a CEN member into its own language and notified to the CEN Management Centre has the same status as the official versions.

[SIST EN 3372-008:2009](https://standards.iteh.ai/catalog/standards/sist/762efb4b-1c32-493d-8313-010101010101/EN-3372-008)

CEN members are the national standards bodies of Austria, Belgium, Bulgaria, Cyprus, Czech Republic, Denmark, Estonia, Finland, France, Germany, Greece, Hungary, Iceland, Ireland, Italy, Latvia, Lithuania, Luxembourg, Malta, Netherlands, Norway, Poland, Portugal, Romania, Slovakia, Slovenia, Spain, Sweden, Switzerland and United Kingdom.



EUROPEAN COMMITTEE FOR STANDARDIZATION
COMITÉ EUROPÉEN DE NORMALISATION
EUROPÄISCHES KOMITEE FÜR NORMUNG

Management Centre: rue de Stassart, 36 B-1050 Brussels

Contents

Page

Foreword.....	3
1 Scope	4
2 Normative references	4
3 Terms and definitions	4
4 Required characteristics	5
5 Designation	6
6 Marking	7
7 Technical specification	7

iTeh STANDARD PREVIEW
(standards.iteh.ai)

SIST EN 3372-008:2009

<https://standards.iteh.ai/catalog/standards/sist/762efb4b-1c32-493d-8313-504f181375e9/sist-en-3372-008-2009>

Foreword

This document (EN 3372-008:2007) has been prepared by the Aerospace and Defence Industries Association of Europe - Standardization (ASD-STAN).

After enquiries and votes carried out in accordance with the rules of this Association, this Standard has received the approval of the National Associations and the Official Services of the member countries of ASD, prior to its presentation to CEN.

This European Standard shall be given the status of a national standard, either by publication of an identical text or by endorsement, at the latest by January 2008, and conflicting national standards shall be withdrawn at the latest by January 2008.

According to the CEN/CENELEC Internal Regulations, the national standards organizations of the following countries are bound to implement this European Standard: Austria, Belgium, Bulgaria, Cyprus, Czech Republic, Denmark, Estonia, Finland, France, Germany, Greece, Hungary, Iceland, Ireland, Italy, Latvia, Lithuania, Luxembourg, Malta, Netherlands, Norway, Poland, Portugal, Romania, Slovakia, Slovenia, Spain, Sweden, Switzerland and the United Kingdom.

iTeh STANDARD PREVIEW (standards.iteh.ai)

[SIST EN 3372-008:2009](https://standards.iteh.ai/catalog/standards/sist/762efb4b-1c32-493d-8313-504f181375e9/sist-en-3372-008-2009)

<https://standards.iteh.ai/catalog/standards/sist/762efb4b-1c32-493d-8313-504f181375e9/sist-en-3372-008-2009>

EN 3372-008:2007 (E)**1 Scope**

This standard specifies the characteristics of the free plug connector fitted with a grounding spring in the family of circular electrical connectors coupled by bayonet ring.

It applies to class defined in Table 3.

For contacts, filler plugs and rear accessories associated with this receptacle see EN 3372-002. For receptacles and protective covers, see EN 3372-003, EN 3372-004, EN 3372-005, EN 3372-007, EN 3372-009 and EN 3372-010 respectively.

2 Normative references

The following referenced documents are indispensable for the application of this document. For dated references, only the edition cited applies. For undated references, the latest edition of the referenced document (including any amendments) applies.

EN 3155-002, *Aerospace series — Electrical contacts used in elements of connection — Part 002: List and utilization of contacts*

EN 3372-001, *Aerospace series — Connectors, electrical, circular, medium and high contact density, scoop-proof with bayonet coupling, operating temperatures –65 °C to 175 °C or 200 °C continuous — Part 001: Technical specification¹⁾*

EN 3372-002, *Aerospace series — Connectors, electrical, circular, medium and high contact density, scoop-proof with bayonet coupling, operating temperatures –65 °C to 175 °C or 200 °C continuous — Part 002: Specification of performance and contact arrangements*

EN 3372-003, *Aerospace series — Connectors, electrical, circular, medium and high contact density, scoop-proof with bayonet coupling, operating temperatures –65 °C to 175 °C or 200 °C continuous — Part 003: Square flange receptacle — Product standard 3372-008:2009*

EN 3372-004, *Aerospace series — Connectors, electrical, circular, medium and high contact density, scoop-proof with bayonet coupling, operating temperatures –65 °C to 175 °C or 200 °C continuous — Part 004: Receptacle, hermetic, square flange mounting — Product standard¹⁾*

EN 3372-005, *Aerospace series — Connectors, electrical, circular, medium and high contact density, scoop-proof with bayonet coupling, operating temperatures –65 °C to 175 °C or 200 °C continuous — Part 005: Receptacle, hermetic, round flange, solder mounting — Product standard*

EN 3372-007, *Aerospace series — Connectors, electrical, circular, medium and high contact density, scoop-proof with bayonet coupling, operating temperatures –65 °C to 175 °C or 200 °C continuous — Part 007: Protective cover for plug — Product standard*

EN 3372-009, *Aerospace series — Connectors, electrical, circular, medium and high contact density, scoop-proof with bayonet coupling, operating temperatures –65 °C to 175 °C or 200 °C continuous — Part 009: Receptacle, round flange, jam nut mounting — Product standard*

EN 3372-010, *Aerospace series — Connectors, electrical, circular, medium and high contact density, scoop-proof with bayonet coupling, operating temperatures –65 °C to 175 °C or 200 °C continuous — Part 010: Receptacle, hermetic, round flange, jam nut mounting — Product standard¹⁾*

3 Terms and definitions

For the purposes of this standard, the terms and definitions given in EN 3372-001 apply.

¹⁾ In preparation at the date of publication of this standard

4 Required characteristics

4.1 Dimensions, mass

See Figure 1 and Table 1.

Dimensions apply after surface treatment

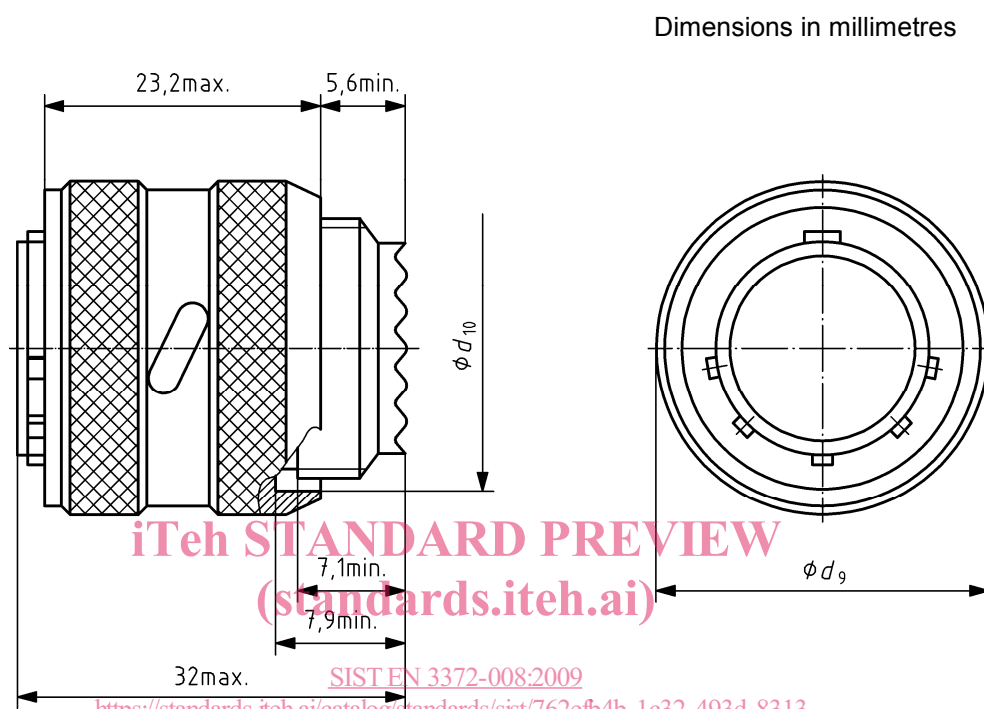

Figure 1 — Plug

Table 1 — Dimensions and mass

Housing size	d_9 mm max.	d_{10} mm max.	Mass g ^a max.	
			Pin	Socket
08	19,0	15,67	9,0	11,0
10	22,0	18,87	12,0	16,0
12	26,0	22,02	19,0	23,0
14	29,0	25,22	21,0	34,0
16	33,0	28,42	26,0	38,0
18	36,0	31,57	33,0	52,0
20	39,0	34,77	37,0	57,0
22	44,0	37,92	48,0	68,0
24	46,0	41,12	58,0	91,0

^a Mass with contacts and without accessories.

EN 3372-008:2007 (E)**4.2 Material, surface treatment**

See Table 2.

4.3 Main general characteristics

According to EN 3372-002.

4.4 Possible combinations of plugs and receptacles

According to EN 3372-002.

5 Designation

EXAMPLE

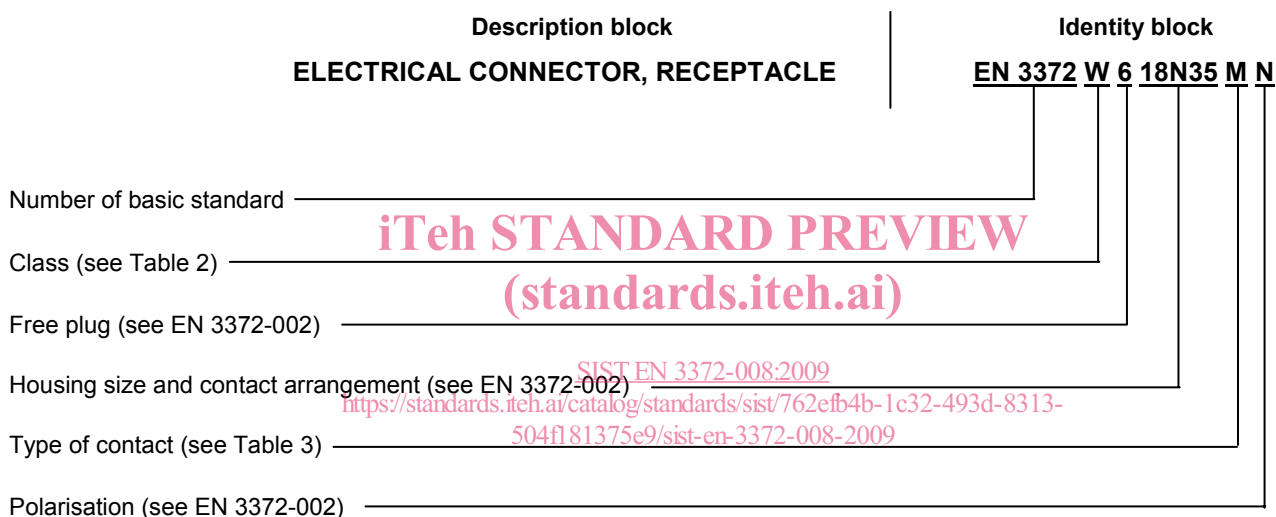

NOTE If necessary, the code I9005 shall be placed between the description block and the identity block.

Table 2 — Connector class

Class	Description
W	Cadmium-plated aluminium alloy, olive drab — 500 h salt mist — Plug with grounding spring — Crimp, removable contacts — Maximum operating temperature 175 °C continuous
F	Nickel-plated aluminium alloy — 48 h salt mist — Plug with grounding spring — Crimp, removable contacts — Maximum operating temperature 200 °C continuous