



# SLOVENSKI STANDARD SIST EN 4035:2009

01-september-2009

5 YfcbUj h\_U!`BUghUj`'j]`Xfgb]`n[ ]V]`g'gUa cj Ufcj Ub]a `Xj cfYXb]a `b] Ub]a  
\_fc[ `] b]a `YyUYa `]n`\_cfc]`g\_c`cXdcfbY[ U`Y\_`Užn`na Ub`yUb]a `fUX]Ub]a `c\ `Udca  
`YyUU]b`bUj c`b]a `ghV`ca `]n`h]Ubcj Y`n`]h]bY!`A YfY]b`bcg]`bcgh]

Aerospace series - Rod ends, adjustable with self-aligning double row ball bearing in corrosion resisting steel, reduced internal radial clearance and threaded shank in titanium alloy - Dimensions and loads

iTeh STANDARD PREVIEW

(standards.iteh.ai)  
Luft- und Raumfahrt - Einstellbare Ösenköpfe mit zweireihigem Pendelkugellager aus korrosionsbeständigem Stahl, reduzierte radiale Lagerluft und Gewindeschaft aus Titanlegierung - Maße und Belastungen

SIST EN 4035:2009

<https://standards.iteh.ai/catalog/standards/sist/3ca87197-e969-4377-a08c->

Série aérospatiale - Embouts réglables à rotule sur deux rangées de billes en acier résistant à la corrosion, jeu radial réduit et à tige filetée en alliage de titane - Dimensions et charges

Ta slovenski standard je istoveten z: EN 4035:2006

## ICS:

49.035

Sestavni deli za letalsko in  
vesoljsko gradnjo

Components for aerospace  
construction

SIST EN 4035:2009

en,de

**iTeh STANDARD PREVIEW**  
**(standards.iteh.ai)**

SIST EN 4035:2009

<https://standards.iteh.ai/catalog/standards/sist/3ca87197-e969-4377-a08c-0920ab47256c/sist-en-4035-2009>

EUROPEAN STANDARD  
NORME EUROPÉENNE  
EUROPÄISCHE NORM

**EN 4035**

May 2006

ICS 49.035

English Version

**Aerospace series - Rod ends, adjustable with self-aligning  
double row ball bearing in corrosion resisting steel, reduced  
internal radial clearance and threaded shank in titanium alloy -  
Dimensions and loads**

Série aérospatiale - Embouts réglables à rotule sur deux rangées de billes en acier résistant à la corrosion, jeu radial réduit et à tige fileté en alliage de titane - Dimensions et charges

Luft- und Raumfahrt - Einstellbare Ösenköpfe mit zweireihigem Pendelkugellager aus korrosionsbeständigem Stahl, reduzierte radiale Lagerluft und Gewindeschaft aus Titanlegierung - Maße und Belastungen

This European Standard was approved by CEN on 16 March 2006.

CEN members are bound to comply with the CEN/CENELEC Internal Regulations which stipulate the conditions for giving this European Standard the status of a national standard without any alteration. Up-to-date lists and bibliographical references concerning such national standards may be obtained on application to the Central Secretariat or to any CEN member.

This European Standard exists in three official versions (English, French, German). A version in any other language made by translation under the responsibility of a CEN member into its own language and notified to the Central Secretariat has the same status as the official versions.

[SIST EN 4035:2009](https://standards.iteh.ai/catalog/standards/sist/3ca87107-e969-4377-e08c-093011477355/EN-4035-2006)

CEN members are the national standards bodies of Austria, Belgium, Cyprus, Czech Republic, Denmark, Estonia, Finland, France, Germany, Greece, Hungary, Iceland, Ireland, Italy, Latvia, Lithuania, Luxembourg, Malta, Netherlands, Norway, Poland, Portugal, Romania, Slovakia, Slovenia, Spain, Sweden, Switzerland and United Kingdom.



EUROPEAN COMMITTEE FOR STANDARDIZATION  
COMITÉ EUROPÉEN DE NORMALISATION  
EUROPÄISCHES KOMITEE FÜR NORMUNG

**Management Centre: rue de Stassart, 36 B-1050 Brussels**

<b>Contents</b>		<b>Page</b>
Foreword .....		3
<b>1</b>	<b>Scope .....</b>	<b>4</b>
<b>2</b>	<b>Normative references .....</b>	<b>4</b>
<b>3</b>	<b>Terms and definitions .....</b>	<b>5</b>
<b>4</b>	<b>Symbols and abbreviations.....</b>	<b>5</b>
<b>5</b>	<b>Required characteristics .....</b>	<b>5</b>
<b>6</b>	<b>Designation .....</b>	<b>9</b>
<b>7</b>	<b>Marking .....</b>	<b>9</b>
<b>8</b>	<b>Technical specification.....</b>	<b>9</b>

**iTeh STANDARD PREVIEW**  
**(standards.iteh.ai)**

SIST EN 4035:2009

<https://standards.iteh.ai/catalog/standards/sist/3ca87197-e969-4377-a08c-0920ab47256c/sist-en-4035-2009>

## Foreword

This European Standard (EN 4035:2006) has been prepared by the European Association of Aerospace Manufacturers - Standardization (AECMA-STAN).

After enquiries and votes carried out in accordance with the rules of this Association, this Standard has received the approval of the National Associations and the Official Services of the member countries of AECMA, prior to its presentation to CEN.

This European Standard shall be given the status of a national standard, either by publication of an identical text or by endorsement, at the latest by November 2006, and conflicting national standards shall be withdrawn at the latest by November 2006.

Attention is drawn to the possibility that some of the elements of this document may be the subject of patent rights. CEN [and/or CENELEC] shall not be held responsible for identifying any or all such patent rights.

According to the CEN/CENELEC Internal Regulations, the national standards organizations of the following countries are bound to implement this European Standard: Austria, Belgium, Cyprus, Czech Republic, Denmark, Estonia, Finland, France, Germany, Greece, Hungary, Iceland, Ireland, Italy, Latvia, Lithuania, Luxembourg, Malta, Netherlands, Norway, Poland, Portugal, Romania, Slovakia, Slovenia, Spain, Sweden, Switzerland and the United Kingdom.

**ITIH STANDARD PREVIEW**  
**(standards.iteh.ai)**

SIST EN 4035:2009

<https://standards.iteh.ai/catalog/standards/sist/3ca87197-e969-4377-a08c-0920ab47256c/sist-en-4035-2009>

**EN 4035:2006 (E)****1 Scope**

This standard specifies the characteristics of adjustable rod ends with self-aligning double row ball bearing in corrosion resisting steel with reduced internal radial clearance and threaded shank in titanium alloy, designed to withstand only slow rotations and oscillations under load.

They consist of:

- a rod end comprising:
  - circumferential groove to identify location;
  - either seals or shields;
  - an optional longitudinal groove for locking purpose;
- an inner ring with balls.

These rod ends are intended for use with flight control rods or rods for aerospace structures.

They are intended to be used in the temperature range: – 54 °C to 150 °C.

However, being lubricated with the following greases:

- very high pressure grease, ester type (code A), operational range – 73 °C to 121 °C or
- very high pressure grease, synthetic hydrocarbons, general purpose (code B), operational range – 54 °C to 177 °C (see EN 2067),

their field of application when lubricated with code A grease is limited to 121 °C.

**2 Normative references**

The following referenced documents are indispensable for the application of this document. For dated references, only the edition cited applies. For undated references, the latest edition of the referenced document (including any amendments) applies.

ISO 1132-1, *Rolling bearings — Tolerances — Part 1: Terms and definitions.*

ISO 3353-1, *Aerospace — Lead and runout threads — Part 1: Rolled external threads.*

ISO 5855-2, *Aerospace — MJ threads — Part 2: Limit dimensions for bolts and nuts.*

ISO 8075, *Aerospace — Surface treatment of hardenable stainless steel parts.*

EN 2067, *Aerospace series — Rod ends with self-aligning ball bearings — Technical specification.*

EN 2424, *Aerospace series — Marking of aerospace products.*

EN 2808, *Aerospace series — Anodizing of titanium and titanium alloys.*

EN 3289, *Aerospace series — Bearings, airframe rolling — Double row self-aligning ball bearings in corrosion resisting steel — Diameter series 2 — Dimensions and loads.*

EN 3315, *Aerospace series — Titanium alloy TI-P64001 — Solution treated and aged — Forgings —  $D_e \leq 75$  mm.* <sup>1)</sup>

EN 3353<sup>2)</sup>, *Aerospace series — Titanium alloy Ti-P63, solution treated and aged —  $R_m \geq 1$  100 MPa — Bar and wire for fasteners machined —  $D_e \leq 25$  mm.* <sup>1)</sup>

EN 3813, *Aerospace series — Titanium alloy TI-P64001 — Annealed — Bar and wire for forged fasteners —  $D_e \leq 25$  mm.* <sup>1)</sup>

TR 3775, *Aerospace series — Bolts and pins — Materials.* <sup>3)</sup>

### 3 Terms and definitions

For the purposes of this standard, the terms and definitions given in ISO 1132-1 apply.

### 4 Symbols and abbreviations

$\Delta_{ds}$	=	deviation of a single bore diameter
$\Delta_{dmp}$	=	single plane mean bore diameter deviation
$C_s$	=	permissible static radial load
$F_a$ max.	=	permissible static axial load

STANDARD PREVIEW  
(standards.iteh.ai)

### 5 Required characteristics

#### 5.1 Dimensions — Tolerances — Masses

Configuration : see Figure 1; the bearings are fitted with either seals or shields.

Values : see Figure 1 and Table 1: values after surface treatment.

#### 5.2 Surfaces roughness

Rolling elements and raceway:  $R_a = 0,2 \mu\text{m}$

Bore, side faces and cylindrical outer surface:  $R_a = 0,8 \mu\text{m}$

For code T values prior to the surface treatment

1) Published as AECMA Prestandard at the date of publication of this standard.

2) Inactive for new design, see EN 3813.

3) Published as AECMA Technical Report at the date of publication of this standard.

**EN 4035:2006 (E)****5.3 Materials**

Rod end : Titanium alloy EN 3315 or EN 3353 or TR 3775 by hardening and tempering to a strength of  $R_m > 830$  MPa on the whole rod end.

Bearing	:	Outer ring	}	see EN 3289
		Inner ring		
		Balls		
		Shields		
		Seals		

**5.4 Surface treatment**

Rod end : anodizing EN 2808

Bearing : passivation ISO 8075: code T  
with no surface treatment : no code

**5.5 Thread**

MJ thread to ISO 5855-2, rolled

Right hand thread, code R

Left hand thread, code L

**iTeh STANDARD PREVIEW**  
**(standards.iteh.ai)**

SIST EN 4035:2009

<https://standards.iteh.ai/catalog/standards/sist/3ca87197-e969-4377-a08c-0920ab47256c/sist-en-4035-2009>



3,2 / [ 0,8 / 0,8 ]

Break sharp edges and corners and remove all burrs and slivers

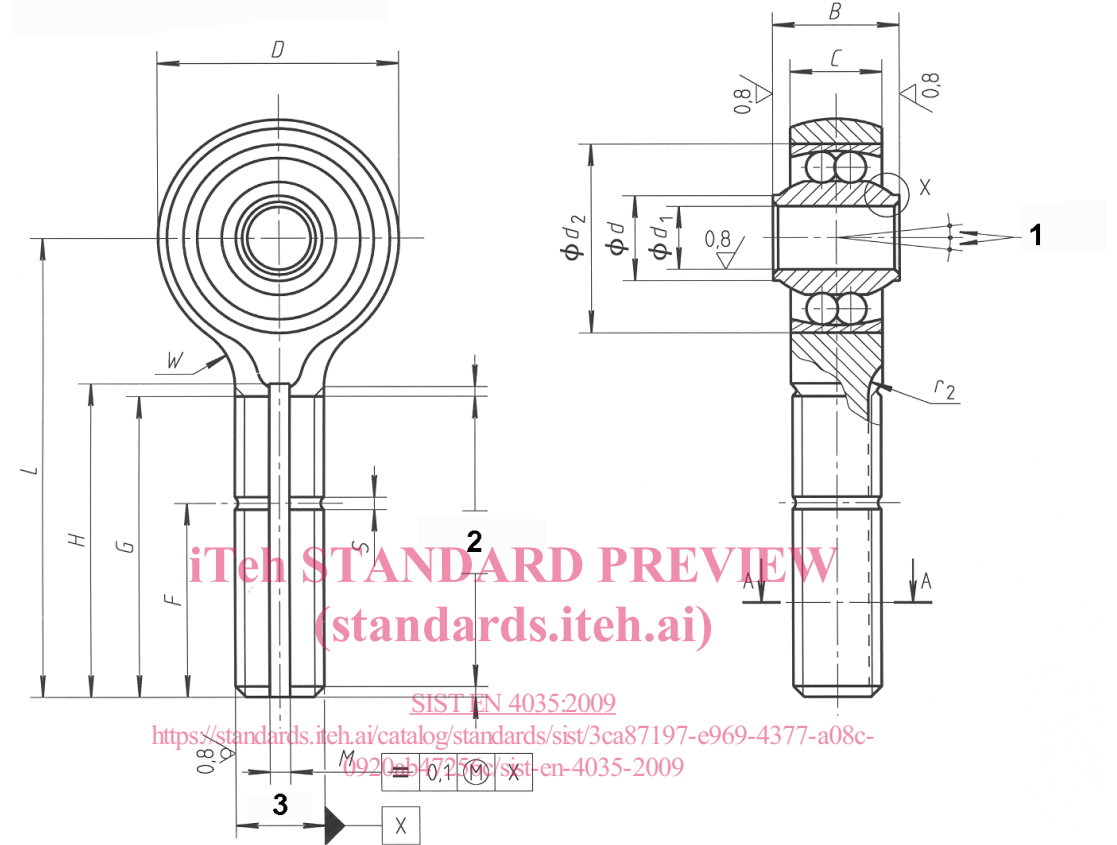

**iTeh STANDARD PREVIEW**  
(standards.iteh.ai)

SIST EN 4035:2009

<https://standards.iteh.ai/catalog/standards/sist/3ca87197-e969-4377-a08c-0920-b47250/sist-en-4035-2009>

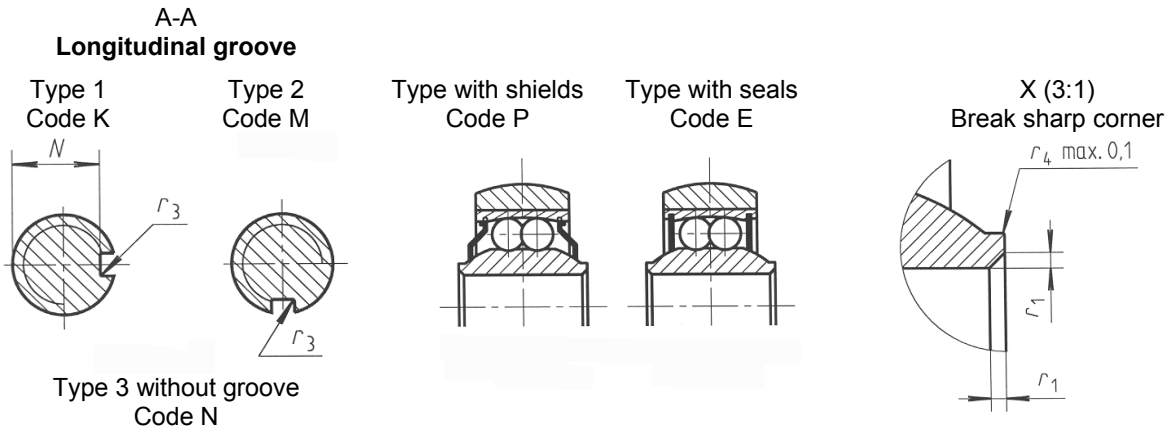

**Key**

- 1 6° min. The acceptance value is the maximum value for the user.
- 2 Conform to ISO 3353-1.
- 3 Thread

**Figure 1**

NOTE 1 The circumferential groove and the longitudinal groove over the distance  $F$  shall be painted red.