



SLOVENSKI STANDARD SIST EN 4531-001:2009

01-julij-2009

5 YfcbUj h_U! ?cbY_lcf jZcdh b]žc_fc[]žn`Yb]a `U]`j Y `nUj]ždf_`f Yb]n
bUj c`b]a `cVfc _ca `!`nfUj bUb]_cbhU_h]! \$\$\$%`XY.`HY b] bUgdYWZ_UYU

Aerospace series - Connectors, optical, circular, single and multipin, coupled by threaded ring - Flush contacts - Part 001: Technical specification

Luft- und Raumfahrt - Optische Rundsteckverbinder mit Schraubkupplung - Bündige Kontakte - Teil 001: Technische Lieferbedingungen

Série aérospatiale - Connecteurs optiques circulaires à accouplement par bague fileté - Contacts affleurants - Partie 001 : Spécification technique

<https://standards.iteh.ai/catalog/standards/sist/5063c554-b9f9-4b71-b491-d657655ea019/sist-en-4531-001-2009>

Ta slovenski standard je istoveten z: **EN 4531-001:2007**

ICS:

49.060 Š^cp \ æš Ą^• [|b \ æ Aerospace electric
^|\ dā } æ [] ! ^ { æš Ą ã c { ã equipment and systems

SIST EN 4531-001:2009

en,de

iTeh STANDARD PREVIEW
(standards.iteh.ai)

[SIST EN 4531-001:2009](#)

<https://standards.iteh.ai/catalog/standards/sist/5063c554-b9f9-4b71-b491-d657655ea019/sist-en-4531-001-2009>

EUROPEAN STANDARD
NORME EUROPÉENNE
EUROPÄISCHE NORM

EN 4531-001

June 2007

ICS 49.060

English Version

**Aerospace series - Connectors, optical, circular, single and
multipin, coupled by threaded ring - Flush contacts - Part 001:
Technical specification**

Série aérospatiale - Connecteurs optiques circulaires à
accouplement par bague fileté - Contacts affleurants -
Partie 001 : Spécification technique

Luft- und Raumfahrt - Optische Rundsteckverbinder mit
Schraubkupplung - Bündige Kontakte - Teil 001:
Technische Lieferbedingungen

This European Standard was approved by CEN on 28 April 2006.

CEN members are bound to comply with the CEN/CENELEC Internal Regulations which stipulate the conditions for giving this European Standard the status of a national standard without any alteration. Up-to-date lists and bibliographical references concerning such national standards may be obtained on application to the CEN Management Centre or to any CEN member.

This European Standard exists in three official versions (English, French, German). A version in any other language made by translation under the responsibility of a CEN member into its own language and notified to the CEN Management Centre has the same status as the official versions.

CEN members are the national standards bodies of Austria, Belgium, Bulgaria, Cyprus, Czech Republic, Denmark, Estonia, Finland, France, Germany, Greece, Hungary, Iceland, Ireland, Italy, Latvia, Lithuania, Luxembourg, Malta, Netherlands, Norway, Poland, Portugal, Romania, Slovakia, Slovenia, Spain, Sweden, Switzerland and United Kingdom.

<https://standards.iteh.ai/Catalog/standards/sist/3069C54-b9f9-4b71-b491-d657655ea019/sist-en-4531-001-2009>



EUROPEAN COMMITTEE FOR STANDARDIZATION
COMITÉ EUROPÉEN DE NORMALISATION
EUROPÄISCHES KOMITEE FÜR NORMUNG

Management Centre: rue de Stassart, 36 B-1050 Brussels

Contents

Page

Foreword.....	3
Introduction	4
1 Scope	4
2 Normative references	4
3 Terms and definitions	5
4 Description	5
5 Design	6
6 Definition drawings and masses	7
7 Tests	26
8 Quality assurance	31
9 Designation and marking	35

iTeh STANDARD PREVIEW
(standards.iteh.ai)

[SIST EN 4531-001:2009](https://standards.iteh.ai/catalog/standards/sist/5063c554-b9f9-4b71-b491-d657655ea019/sist-en-4531-001-2009)

<https://standards.iteh.ai/catalog/standards/sist/5063c554-b9f9-4b71-b491-d657655ea019/sist-en-4531-001-2009>

Foreword

This document (EN 4531-001:2007) has been prepared by the Aerospace and Defence Industries Association of Europe - Standardization (ASD-STAN).

After enquiries and votes carried out in accordance with the rules of this Association, this Standard has received the approval of the National Associations and the Official Services of the member countries of ASD, prior to its presentation to CEN.

This European Standard shall be given the status of a national standard, either by publication of an identical text or by endorsement, at the latest by December 2007, and conflicting national standards shall be withdrawn at the latest by December 2007.

Attention is drawn to the possibility that some of the elements of this document may be the subject of patent rights. CEN [and/or CENELEC] shall not be held responsible for identifying any or all such patent rights.

According to the CEN/CENELEC Internal Regulations, the national standards organizations of the following countries are bound to implement this European Standard: Austria, Belgium, Bulgaria, Cyprus, Czech Republic, Denmark, Estonia, Finland, France, Germany, Greece, Hungary, Iceland, Ireland, Italy, Latvia, Lithuania, Luxembourg, Malta, Netherlands, Norway, Poland, Portugal, Romania, Slovakia, Slovenia, Spain, Sweden, Switzerland and the United Kingdom.

ITEH STANDARD PREVIEW
(standards.iteh.ai)

[SIST EN 4531-001:2009](https://standards.iteh.ai/catalog/standards/sist/5063c554-b9f9-4b71-b491-d657655ea019/sist-en-4531-001-2009)

<https://standards.iteh.ai/catalog/standards/sist/5063c554-b9f9-4b71-b491-d657655ea019/sist-en-4531-001-2009>

Introduction

This family of fibre optic connectors is derived from MIL-DTL-38999K series III and EN 3645-001. It is suitable for use on aerospace onboard applications. It provides easy access for optical contact end face cleaning.

The connectors with shell size 9, 11 and 13 are 100 % scoop proof. The optical contacts are capable of accepting single cable sizes up to a maximum of 2,5 mm outside diameter.

1 Scope

This standard specifies the general characteristics, the conditions for qualification, acceptance and quality assurance, as well as the test programs and groups for threaded ring coupling circular fibre optic self-locking connectors, fire-resistant or non fire-resistant, intended for use in a temperature range from – 65 °C to 150 °C (cable dependent) continuous.

2 Normative references

The following referenced documents are indispensable for the application of this document. For dated references, only the edition cited applies. For undated references, the latest edition of the referenced document (including any amendments) applies.

ISO 263, *ISO inch screw threads — General plan and selection for screws, bolts and nuts — Diameter range 0.06 to 6 in.*

[SIST EN 4531-001:2009](https://standards.iteh.ai/catalog/standards/sist/5063c554-b9f9-4b71-b491-5540c1e24100)

<https://standards.iteh.ai/catalog/standards/sist/5063c554-b9f9-4b71-b491-5540c1e24100>

EN 2591-100*, *Aerospace series — Elements of electrical and optical connection — Test methods — Part 100: General.*

EN 3197, *Aerospace series — Installation of aircraft electrical and optical interconnection systems.*¹⁾

EN 3645 (all parts), *Aerospace series — Connectors, electrical, circular, scoop-proof, triple start threaded coupling operating temperatures 175 °C or 200 °C continuous.*¹⁾

EN 4531-002, *Aerospace series — Connectors, optical, circular, single and multipin, coupled by threaded ring — Flush contacts — Part 002: Specification of performance and contact arrangements.*

EN 9133, *Aerospace series — Quality management systems — Qualification procedure for aerospace standard parts.*

AS 1241A, *Fire resistant phosphate ester hydraulic fluid for aircraft.*²⁾

AMS 1424, *Deicing/Anti-Icing Fluid, Aircraft — SAE Type I.*²⁾

MIL-PRF-87937D, *Cleaning compound, aerospace equipment.*³⁾

* All its parts quoted.

1) Published as ASD Prestandard at the date of publication of this standard.

2) Published by: Society of Automotive Engineers, Inc. (SAE) 400 Commonwealth Drive, Warrendale, PA 15096-0001 USA.

3) Published by: Department of Defense (DOD), the Pentagon, Washington, D.C. 20301 USA.

MIL-DTL-38999K, *Connectors, electrical, circular, miniature, high density, quick disconnect (bayonet, threaded, and breech coupling), environment resistant, removable crimp and hermetic solder contacts, general specification for.* ³⁾

MIL-PRF-5606H, *Hydraulic fluid, petroleum base, aircraft, missile and ordnance.* ³⁾

MIL-I-81969/8B, *Installing and removal tools, connector electrical contact, type I and II, class 2, composition A.* ³⁾

MIL-PRF-7808L, *Lubricating oil, aircraft turbine engine, synthetic base.* ³⁾

MIL-PRF-7870C, *Lubricating oil, general purpose, low temperature.* ³⁾

MIL-PRF-23699F, *Lubricating oil, aircraft turbine engine, synthetic base, NATO CODE number O-156.* ³⁾

MIL-STD-1373, *Screw thread, modified, 60°, stub, double.* ³⁾

3 Terms and definitions

For the purposes of this European Standard, the terms and definitions given in EN 2591-100 apply.

4 Description

4.1 General

iTeh STANDARD PREVIEW
(standards.iteh.ai)

The connectors utilise rear removable optical contacts with a ferrule diameter of 2,5 mm.

The receptacles and plugs contain either male insert or female insert. The female insert is characterized by its ability to precisely align the optical contacts.

The precise alignment of the optical contacts is accomplished by alignment sleeves.

The connectors are polarized by means of keyways and keys; polarization is obtained before the male contacts enter the insert of the female contacts and before the coupling ring is engaged. The position of the keying arrangement is given in 6.5.

The visual check of full mating is obtained by masking of a red coloured band on the receptacle.

Connector accessories are defined in EN 4531-002.

4.2 Receptacle

The receptacle contains five keyways in which the keys of the plug engage. The main keyway is fixed and is wider than the others. Polarization is ensured by the different positions which the secondary keyways may take. The position of the insert is fixed relative to the main keyway.

4.3 Plug

The plug contains five keys which engage in the keyways of the receptacle. The main key is wider than the others. Polarization is ensured by the different positions which the secondary keys may take. The position of the insert is fixed relative to the main key.

The coupling ring permanently fitted on the plug enables the connectors to be mated and unmated. The mating torque shall be lower than the unmating torque. The internal thread of the coupling ring may be treated with a suitable lubricant compatible with the performance required in this standard.

EN 4531-001:2007 (E)**4.4 Materials and surface treatment****4.4.1 General**

When dissimilar metals are in close contact, adequate protection against corrosion shall be used for the electromotive force of the cell not to exceed 0,25 V (see EN 3197).

4.4.2 Housings

The material of the connector housings and fittings shall be of suitable material and/or finish to protect against corrosion (see EN 3197) as specified in the product standard.

4.4.3 Optical contacts and alignment sleeves

The material of the optical contacts and alignment sleeves shall be of suitable materials as specified in the appropriate product standard.

The optical contacts in both plug and receptacle are sprung-loaded. The spring force is defined in the product standard.

4.4.4 Metallic or non-metallic materials

The materials used for insert seals, grommets and alignment pins shall have a hardness and mechanical characteristics consistent with the required use.

iTeh STANDARD PREVIEW
(standards.iteh.ai)

5 Design**5.1 Housings**

[SIST EN 4531-001:2009](https://standards.iteh.ai/catalog/standards/sist/5063c554-b9f9-4b71-b491-d657655e019/sist-en-4531-001-2009)

[https://standards.iteh.ai/catalog/standards/sist/5063c554-b9f9-4b71-b491-](https://standards.iteh.ai/catalog/standards/sist/5063c554-b9f9-4b71-b491-d657655e019/sist-en-4531-001-2009)

The connector housings shall be in one unit. They contain teeth at the rear over the entire periphery and shall accommodate the accessories. The receptacle shall be fitted with an internal seal for sealing the coupled housings.

The jam nut receptacle housing shall contain an O-ring seal (panel seal). The lock nut shall be provided with wire locking holes.

Threads shall conform to ISO 263, except for the triple start threads, which shall conform to standard MIL-STD-1373.

The coupling ring shall be designed so that the optical contacts engage when it is screwed clockwise and disengage when it is unscrewed counter clockwise. The coupling ring shall be designed to provide a hand grip profile.

Full locking of the connectors shall occur at approximately 360°. On completion of tightening of the coupling ring, mechanical contact shall exist between the receptacle and plug shells. Masking of a red colour band on the receptacle shall show that the connectors are correctly mated.

The front face of the plug shell shall seal when fully mated with the receptacle connector.

5.2 Inserts

The insert carrying the optical contacts shall be in hard material and have a cross section and radii such that no cracks, flaking or breaks can occur in normal operation.

The insert for contacts shall be non-removable; it shall be mechanically held in the housing. Sealing shall be provided between the housing and insert.

The mechanical contacts retention system shall be integrated in the hard insert.

The design shall permit individual installation of the contacts without removal of the insert.

Fitting and removal of the contacts shall be from the rear. For ease of operation, tools as per MIL-I-81969/8B-10 standard (P/N for size 12) may be used.

Contact position identification shall be permanent and contrasted on the front face of the insert and on the rear face of the insert or grommet.

The male insert shall incorporate two optical contact alignment pins for multiway connectors.

The female insert shall incorporate two optical contact alignment holes for multiway connectors.

6 Definition drawings and masses

6.1 General

The general dimensions and the masses of receptacles, plugs and protective covers are given in the product standards.

6.2 Receptacle mating dimensions

6.2.1 Receptacle with male insert

The mating dimensions of receptacles with the male insert are shown in Figure 1 for shell sizes 11, 13, 17, 21, and 25, Figure 2 for shell size 09 and in Table 1. Same dimensions as EN 3645 connectors.

Dimensions and tolerances are in millimetres.

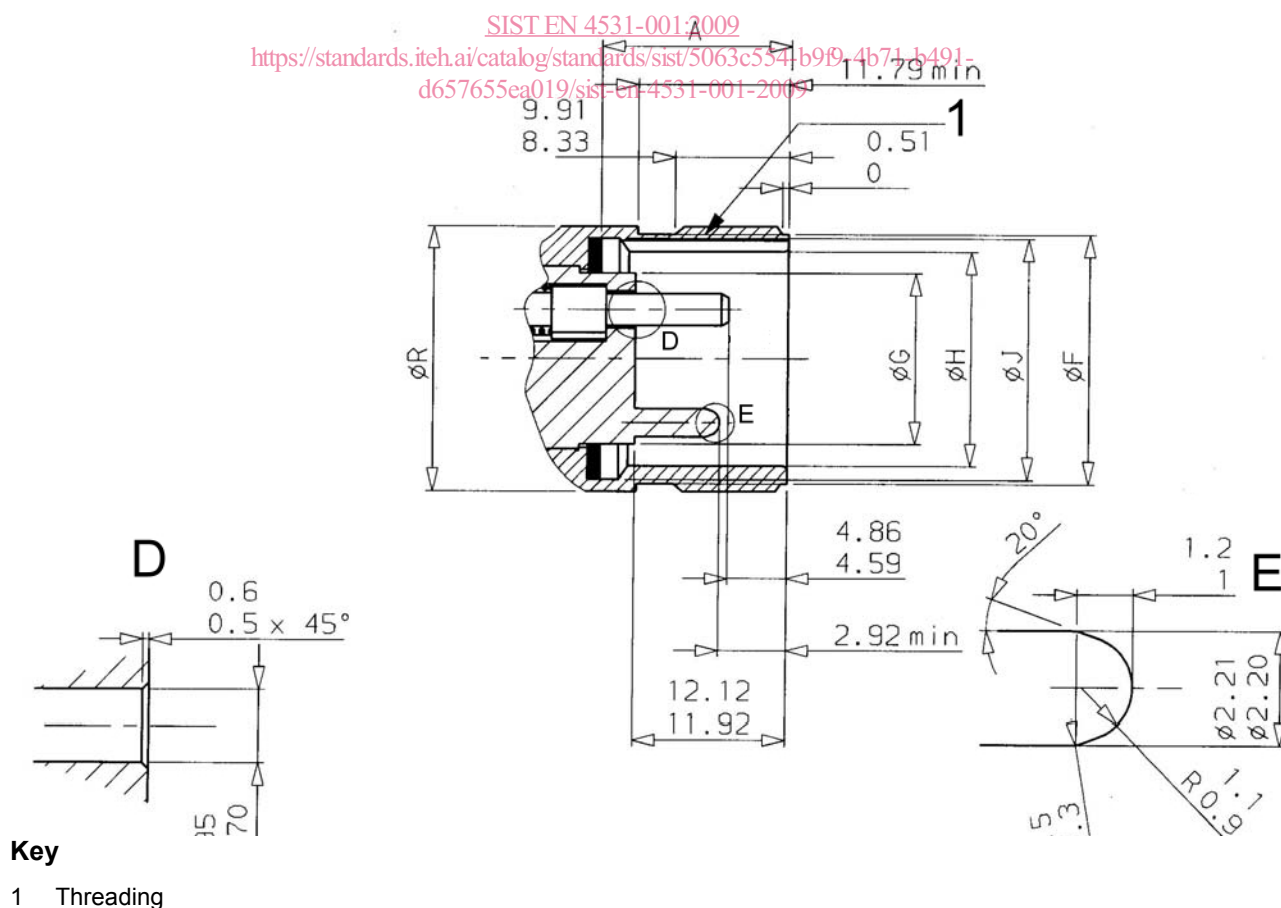
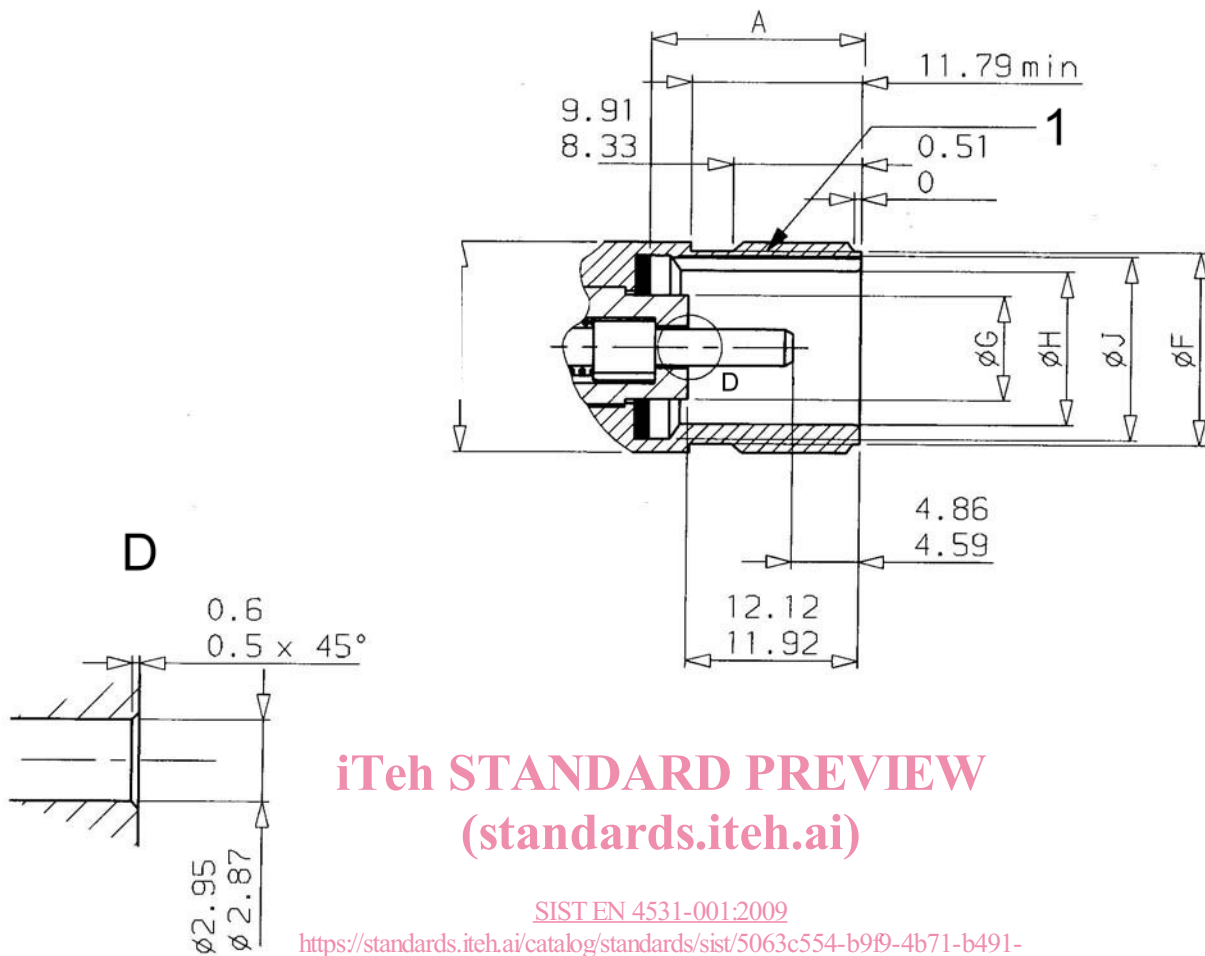

Figure 1 — Drawing for shell sizes 11, 13, 17, 21 and 25

**Key**

1 Threading

Figure 2 — Drawing for shell size 09**Table 1**

Housing size	A gask loc	F	G +0,13 -0,25	H	J	R max.
09	14,73 14,50	14,42 14,14	7,24	11,36 11,20	12,63 12,34	15,88
11		17,60 17,32	10,49	14,61 14,45	15,88 15,60	19,05
13		20,77 20,49	13,39	17,45 17,30	19,66 19,38	22,23
17		28,30 27,97	19,74	23,80 23,64	26,01 25,73	30,16
21		33,07 32,74	25,17	29,64 29,49	31,85 31,57	34,73
25		39,42 39,02	31,52	35,99 35,84	38,20 37,92	41,28

6.2.2 Receptacle with female insert

The mating dimensions of receptacles with female insert are shown in Figure 3 for shell sizes 11, 13, 17, 21, and 25, Figure 4 for shell size 09 and Table 1.

Same dimensions as EN 3645 connectors.

Dimensions and tolerances are in millimetres.

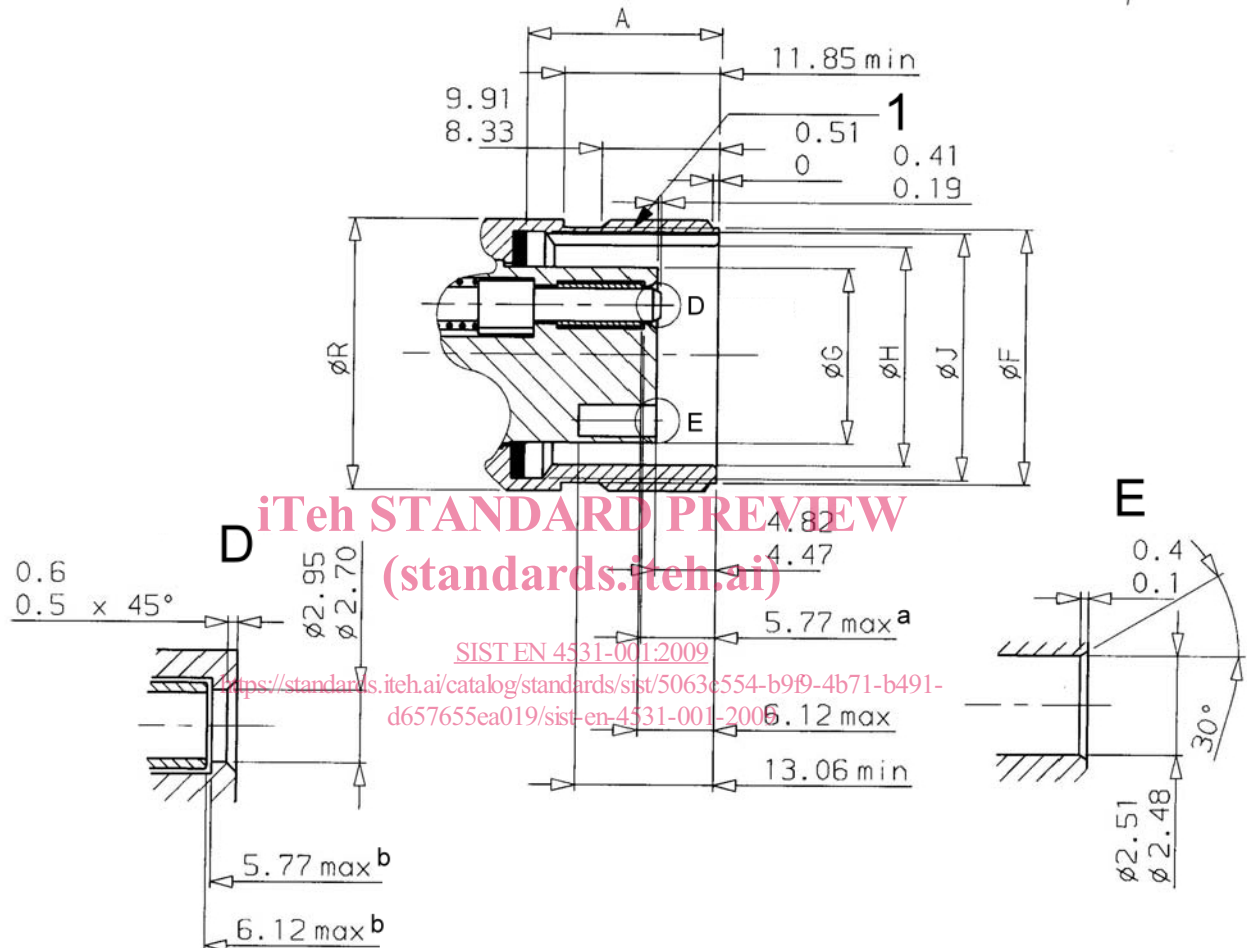

Figure 3 — Drawing for shell sizes 11, 13, 17, 21 and 25

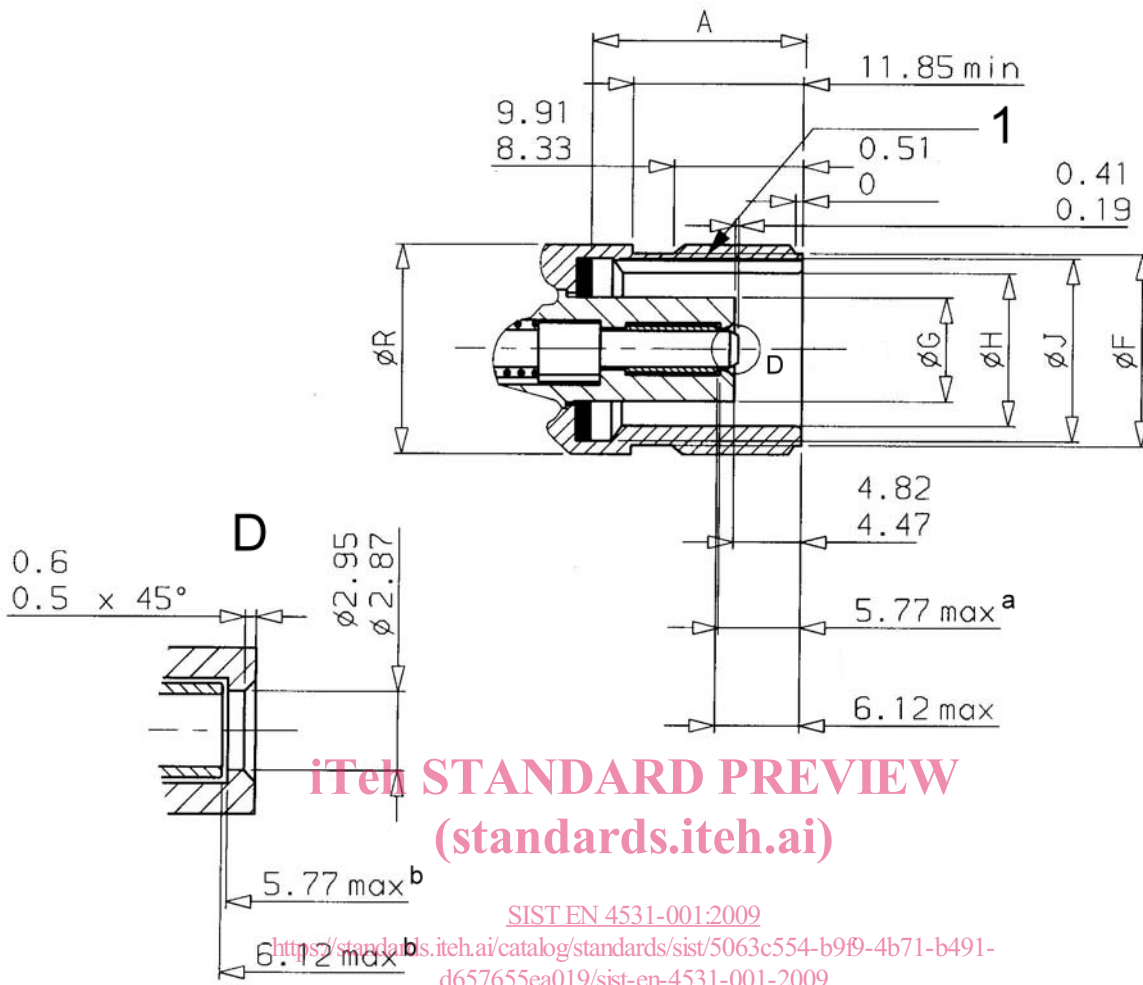

Figure 4 — Drawing for shell size 09