

---

---

**Hexagon head bolts — Product grades A  
and B**

*Vis à tête hexagonale partiellement filetées — Grades A et B*

**iTeh STANDARD PREVIEW**  
**(standards.iteh.ai)**

ISO 4014:1999

<https://standards.iteh.ai/catalog/standards/sist/75072b43-cdb1-4ea3-9202-d92a79f99786/iso-4014-1999>



## Foreword

ISO (the International Organization for Standardization) is a worldwide federation of national standards bodies (ISO member bodies). The work of preparing International Standards is normally carried out through ISO technical committees. Each member body interested in a subject for which a technical committee has been established has the right to be represented on that committee. International organizations, governmental and non-governmental, in liaison with ISO, also take part in the work. ISO collaborates closely with the International Electrotechnical Commission (IEC) on all matters of electrotechnical standardization.

International Standards are drafted in accordance with the rules given in the ISO/IEC Directives, Part 3.

Draft International Standards adopted by the technical committees are circulated to the member bodies for voting. Publication as an International Standard requires approval by at least 75 % of the member bodies casting a vote.

International Standard ISO 4014 was prepared by Technical Committee ISO/TC 2, *Fasteners*.

This third edition cancels and replaces the second edition (ISO 4014:1988) which has been technically revised.

## iTeh STANDARD PREVIEW (standards.iteh.ai)

[ISO 4014:1999](https://standards.iteh.ai/catalog/standards/sist/75072b43-cdb1-4ea3-9202-d92a79f99786/iso-4014-1999)

<https://standards.iteh.ai/catalog/standards/sist/75072b43-cdb1-4ea3-9202-d92a79f99786/iso-4014-1999>

© ISO 1999

All rights reserved. Unless otherwise specified, no part of this publication may be reproduced or utilized in any form or by any means, electronic or mechanical, including photocopying and microfilm, without permission in writing from the publisher.

International Organization for Standardization  
Case postale 56 • CH-1211 Genève 20 • Switzerland  
Internet iso@iso.ch

Printed in Switzerland

## Introduction

This International Standard is part of the complete ISO product standard series on external hexagon drive fasteners. The series comprises:

- a) hexagon head bolts (ISO 4014 to ISO 4016 and ISO 8765);
- b) hexagon head screws (ISO 4017, ISO 4018 and ISO 8676);
- c) hexagon nuts (ISO 4032 to ISO 4036, ISO 8673 to ISO 8675);
- d) hexagon bolts with flange (ISO 4162 and ISO 15071);
- e) hexagon nuts with flange (ISO 4161 and ISO 10663);
- f) structural bolts and nuts (ISO 4775, ISO 7411 to ISO 7414 and ISO 7417).

## iTeh STANDARD PREVIEW (standards.iteh.ai)

[ISO 4014:1999](https://standards.iteh.ai/catalog/standards/sist/75072b43-cdb1-4ea3-9202-d92a79f99786/iso-4014-1999)

<https://standards.iteh.ai/catalog/standards/sist/75072b43-cdb1-4ea3-9202-d92a79f99786/iso-4014-1999>

**iTeh STANDARD PREVIEW**  
**(standards.iteh.ai)**

ISO 4014:1999

<https://standards.iteh.ai/catalog/standards/sist/75072b43-cdb1-4ea3-9202-d92a79f99786/iso-4014-1999>

# Hexagon head bolts — Product grades A and B

## 1 Scope

This International Standard specifies the characteristics of hexagon head bolts with threads from M1,6 up to and including M64, of product grade A for threads M1,6 to M24 and nominal lengths up to and including  $10d$  or 150 mm, whichever is shorter and product grade B for threads over M24 or nominal lengths over  $10d$  or 150 mm, whichever is shorter.

If, in special cases, specifications other than those listed in this International Standard are required, they should be selected from existing International Standards, for example ISO 724, ISO 888, ISO 898-1, ISO 965-1, ISO 3506-1, ISO 4753 and ISO 4759-1.

## 2 Normative references

The following normative documents contain provisions which, through reference in this text, constitute provisions of this International Standard. For dated references, subsequent amendments to, or revisions of, any of these publications do not apply. However, parties to agreements based on this International Standard are encouraged to investigate the possibility of applying the most recent editions of the normative documents indicated below. For undated references, the latest edition of the normative document referred to applies. Members of ISO and IEC maintain registers of currently valid International Standards.

ISO 225:1983, *Fasteners — Bolts, screws, studs and nuts — Symbols and designations of dimensions.*

ISO 724:1993, *ISO general-purpose metric screw threads — Basic dimensions.*

ISO 888:1976, *Bolts, screws and studs — Nominal lengths, and thread lengths for general purpose bolts.*

ISO 898-1:1999, *Mechanical properties of fasteners made of carbon steel and alloy steel — Part 1: Bolts, screws and studs.*

ISO 965-1:1998, *ISO general purpose metric screw threads — Tolerances — Part 1: Principles and basic data.*

ISO 3269:—<sup>1)</sup>, *Fasteners — Acceptance inspection.*

ISO 3506-1:1997, *Mechanical properties of corrosion-resistant stainless-steel fasteners — Part 1: Bolts, screws and studs.*

ISO 4017:1999, *Hexagon head screws — Product grades A and B.*

ISO 4042:1999, *Fasteners — Electroplated coatings.*

ISO 4753:—<sup>2)</sup>, *Fasteners — Ends of parts with external metric ISO thread.*

<sup>1)</sup> To be published. (Revision of ISO 3269:1988)

<sup>2)</sup> To be published. (Revisioin of ISO 4753:1983)

ISO 4759-1:—<sup>3)</sup>, *Tolerances for fasteners — Part 1: Bolts, screws, studs and nuts — Product grades A, B and C.*

ISO 6157-1:1988, *Fasteners — Surface discontinuities — Part 1: Bolts, screws and studs for general requirements.*

ISO 8839:1986, *Mechanical properties of fasteners — Bolts, screws, studs and nuts made of non-ferrous metals.*

ISO 8992:1986, *Fasteners — General requirements for bolts, screws, studs and nuts.*

ISO 10683:—<sup>4)</sup>, *Fasteners — Non-electrolytically applied zinc flake coatings.*

### 3 Dimensions

See Figure 1 and Tables 1 and 2

Symbols and description of dimensions are defined in ISO 225.

## iTeh STANDARD PREVIEW (standards.iteh.ai)

[ISO 4014:1999](https://standards.iteh.ai/catalog/standards/sist/75072b43-cdb1-4ea3-9202-d92a79f99786/iso-4014-1999)

<https://standards.iteh.ai/catalog/standards/sist/75072b43-cdb1-4ea3-9202-d92a79f99786/iso-4014-1999>

---

<sup>3)</sup> To be published. (Revision of ISO 4759-1:1978)

<sup>4)</sup> To be published.

Dimensions in millimetres

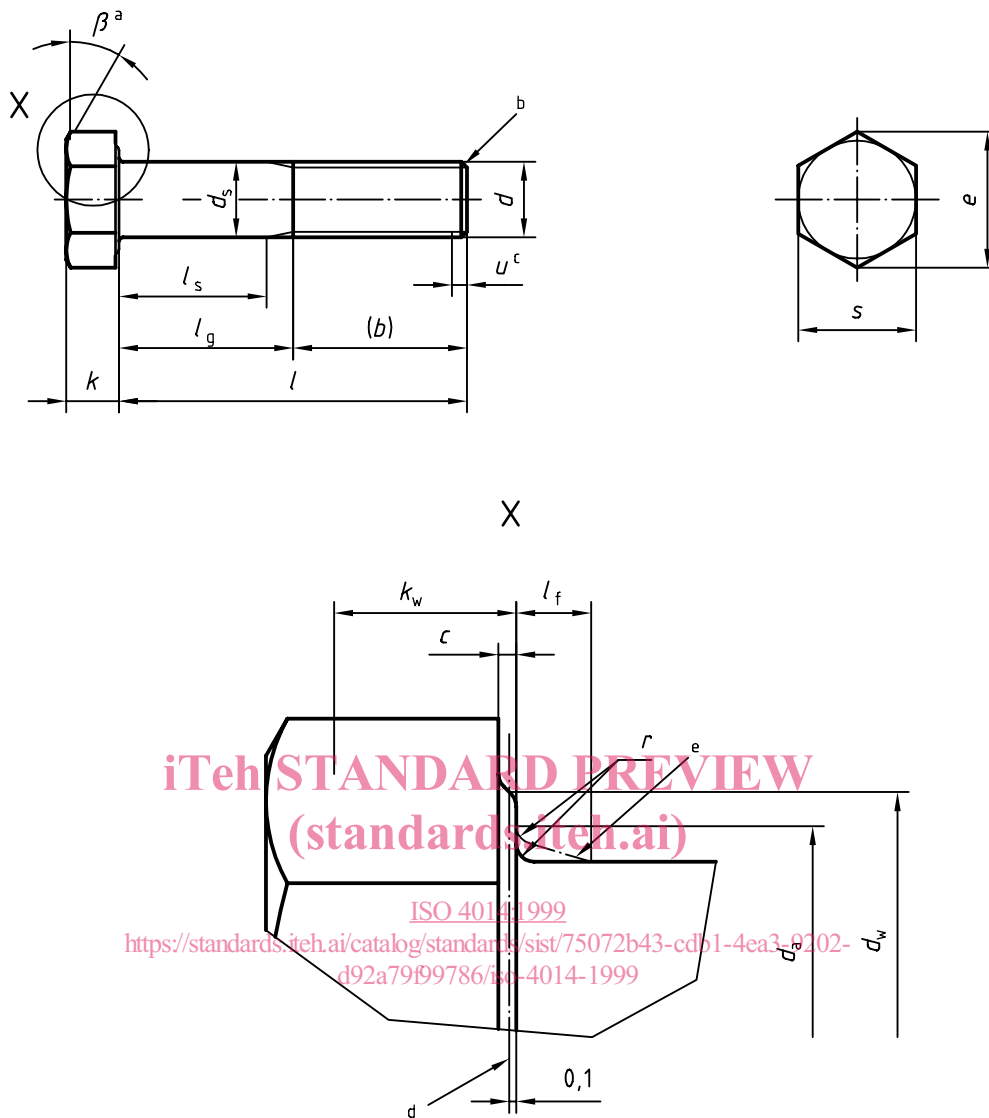

- a  $\beta = 15^\circ$  to  $30^\circ$
- b Point shall be chamfered or for threads  $\leq M4$  may be as-rolled (sheared end) (see ISO 4753)
- c Incomplete thread  $u \leq 2P$
- d Referee datum for  $d_w$
- e Maximum underhead fillet

Figure 1

Table 1 — Preferred threads

Thread (d)	Dimensions in millimetres									
	M1,6	M2	M2,5	M3	M4	M5	M6	M8	M10	
<i>p</i> <sup>a</sup>	0,35	0,4	0,45	0,5	0,7	0,8	1	1,25	1,5	
<i>b</i> ref.	<i>b</i>	9	11	12	14	16	18	22	26	
	<i>c</i>	15	17	18	20	22	24	28	32	
	<i>d</i>	28	30	31	33	35	37	41	45	
<i>c</i>	max.	0,25	0,25	0,40	0,40	0,50	0,50	0,60	0,60	
	min.	0,10	0,10	0,15	0,15	0,15	0,15	0,15	0,15	
<i>d</i> <sub>a</sub>	2	2,6	3,1	3,6	4,7	5,7	6,8	9,2	11,2	
<i>d</i> <sub>s</sub>	nom. = max.	1,60	2,50	3,00	4,00	5,00	6,00	8,00	10,00	
	Product grade	A min. 1,46 B 1,35	1,86 1,75	2,36 2,25	2,86 2,75	3,82 3,70	4,82 4,70	5,82 5,70	7,78 7,64	9,78 9,64
<i>d</i> <sub>w</sub>	Product grade	A min. 2,27 B 2,3	3,07 2,95	4,07 3,95	4,57 4,45	5,88 5,74	6,88 6,74	8,88 8,74	11,63 11,47	14,63 14,47
	Product grade	A min. 3,41 B 3,28	4,32 4,18	5,45 5,31	6,01 5,88	7,66 7,50	8,79 8,63	11,05 10,89	14,38 14,20	17,77 17,59
<i>f</i> <sub>t</sub>	max.	0,6	0,8	1	1,2	1,2	1,4	2	2	
	nom.	1,1	1,4	1,7	2,2	2,8	3,5	5,3	6,4	
<i>k</i>	Product grade	A max. 1,225 min. 0,975	1,525 1,275	1,825 1,575	2,125 1,875	2,925 2,675	3,65 3,35	4,15 3,85	5,45 5,15	6,58 6,22
	Product grade	A max. 1,3 min. 0,9	1,6 1,2	1,9 1,5	2,2 1,8	3,0 2,6	3,26 2,35	4,24 3,76	5,54 5,06	6,69 6,11
<i>k</i> <sub>w</sub> <sup>e</sup>	Product grade	A min. 0,68 B 0,63	0,89 0,84	1,10 1,05	1,31 1,26	1,87 1,82	2,35 2,28	2,70 2,63	3,61 3,54	4,35 4,28
	Product grade	A min. 0,1 nom. = max. 3,20 A min. 3,02 B 2,90	0,1 4,00 3,82 3,70	0,1 5,00 4,82 4,70	0,1 5,50 5,32 5,20	0,2 7,00 6,78 6,64	0,2 8,00 7,78 7,64	0,25 10,00 9,78 9,64	0,4 13,00 12,73 12,57	0,4 16,00 15,73 15,57



nom.	Product grade		$l_s$ and $l_g$																		
	A		B																		
	min.	max.	min.	max.	$l_g$ min.	$l_s$ min.	$l_g$ max.	$l_s$ max.	$l_g$ min.	$l_s$ min.	$l_g$ max.	$l_s$ max.	$l_g$ min.	$l_s$ min.	$l_g$ max.	$l_s$ max.	$l_g$ min.	$l_s$ min.	$l_g$ max.	$l_s$ max.	
12	11,65	12,35	—	—	1,2	—	3	—	—	—	—	—	—	—	—	—	—	—	—	—	—
16	15,65	16,35	—	—	5,2	—	7	—	—	—	—	—	—	—	—	—	—	—	—	—	—
20	19,58	20,42	18,95	21,05	—	4	6	8	10	5,5	8	—	—	—	—	—	—	—	—	—	—
25	24,58	25,42	23,95	26,05	—	—	—	—	—	10,5	13	7,5	11	5	9	—	—	—	—	—	—
30	29,58	30,42	28,95	31,05	—	—	—	—	—	15,5	18	12,5	16	10	14	7	12	—	—	—	—
35	34,5	35,5	33,75	36,25	—	—	—	—	—	17,5	21	17,5	21	15	19	12	17	—	—	—	—
40	39,5	40,5	38,75	41,25	—	—	—	—	—	22,5	26	22,5	26	20	24	17	22	11,75	18	—	—
45	44,5	45,5	43,75	46,25	—	—	—	—	—	—	—	—	—	25	29	22	27	16,75	23	11,5	19
50	49,5	50,5	48,75	51,25	—	—	—	—	—	—	—	—	—	30	34	27	32	21,75	28	16,5	24
55	54,4	55,6	53,5	56,5	—	—	—	—	—	—	—	—	—	—	—	—	—	—	—	—	—
60	59,4	60,6	58,5	61,5	—	—	—	—	—	—	—	—	—	—	—	—	—	—	—	—	—
65	64,4	65,6	63,5	66,5	—	—	—	—	—	—	—	—	—	—	—	—	—	—	—	—	—
70	69,4	70,6	68,5	71,5	—	—	—	—	—	—	—	—	—	—	—	—	—	—	—	—	—
80	79,4	80,6	78,5	81,5	—	—	—	—	—	—	—	—	—	—	—	—	—	—	—	—	—
90	89,3	90,7	88,25	91,75	—	—	—	—	—	—	—	—	—	—	—	—	—	—	—	—	—
100	99,3	100,7	98,25	101,75	—	—	—	—	—	—	—	—	—	—	—	—	—	—	—	—	—
110	109,3	110,7	108,25	111,75	—	—	—	—	—	—	—	—	—	—	—	—	—	—	—	—	—
120	119,3	120,7	118,25	121,75	—	—	—	—	—	—	—	—	—	—	—	—	—	—	—	—	—

For sizes above the solid, boldface stepped line ISO 4017 is recommended

STANDARD PREVIEW  
(standards.itech.ai)  
ISO 4014:1999  
<https://standards.itech.ai/catalog/standards/sist/75072b43-cdb1-4ea3-9202-d93a79f99786/iso-4014-1999>