



Designation: D 217 – 97



Designation: 50/88

AMERICAN SOCIETY FOR TESTING AND MATERIALS  
100 Barr Harbor Dr., West Conshohocken, PA 19428  
Reprinted from the Annual Book of ASTM Standards. Copyright ASTM

## Standard Test Methods for Cone Penetration of Lubricating Grease<sup>1</sup>

This standard is issued under the fixed designation D 217; the number immediately following the designation indicates the year of original adoption or, in the case of revision, the year of last revision. A number in parentheses indicates the year of last reappraisal. A superscript epsilon ( $\epsilon$ ) indicates an editorial change since the last revision or reappraisal.

*These test methods were adopted as a joint ASTM-IP standard in 1969.*

*These test methods have been adopted for use by government agencies to replace Method 311 of Federal Test Method Standard No. 791 b.*

### 1. Scope

1.1 These test methods cover four procedures for measuring the consistency of lubricating greases by the penetration of a cone of specified dimensions, mass, and finish. The penetration is measured in tenths of a millimetre.

NOTE 1—The National Lubricating Grease Institute<sup>2</sup> (NLGI) classified greases according to their consistency as measured by the worked penetration. The classification system is as follows:

NLGI Consistency Number	Worked Penetration Range, 25°C (77°F)
000	445 to 475
00	400 to 430
0	355 to 385
1	310 to 340
2	265 to 295
3	220 to 250
4	175 to 205
5	130 to 160
6	85 to 115

1.1.1 The procedures for unworked, worked, and prolonged worked penetration are applicable to greases having penetrations between 85 and 475, that is, to greases with consistency numbers between NLGI 6 and NLGI 000. An undisturbed penetration test, described in X1, is similar to the unworked penetration test.

1.1.2 The block penetration procedure is applicable to greases that are sufficiently hard to hold their shape. Such greases usually have penetrations below eighty-five tenths of a millimetre.

1.2 None of the four procedures is considered suitable for the measurement of the consistency of petrolatums by penetration. Test Method D 937 should be used for such products.

1.3 The dimensions of the equipment described in these test methods are given in inches and fractions of an inch. These units were retained because a vast body of data has been

obtained using equipment with the dimensions shown. Metric equivalency tables are provided with each figure. Temperatures and other dimensions are given in the preferred SI units; the values shown in parentheses are provided for information.

1.4 *This standard does not purport to address all of the safety concerns, if any, associated with its use. It is the responsibility of the user of this standard to establish appropriate safety and health practices and determine the applicability of regulatory limitations prior to use.*

### 2. Referenced Documents

#### 2.1 ASTM Standards:

D 937 Test Method for Cone Penetration of Petrolatum<sup>3</sup>

D 1403 Test Methods for Cone Penetration of Lubricating Grease Using One-Quarter and One-Half Scale Cone Equipment<sup>3</sup>

### 3. Terminology

#### 3.1 Definitions:

3.1.1 *lubricating grease, n*—a semi-fluid to solid product of a dispersion of a thickener in a liquid lubricant.

3.1.1.1 *Discussion*—The dispersion of the thickener forms a two-phase system and immobilizes the liquid lubricant by surface tension and other physical forces. Other ingredients are commonly included to impart special properties.

3.1.2 *penetrometer, n*—an instrument that measures the consistency or hardness of semiliquid to semisolid materials by measuring the depth to which a specified cone or needle under a given force falls into the material.

3.1.2.1 *Discussion*—In this test method, either a standard penetrometer 6.2 or an optional penetrometer cone A1.3 can be used to determine the consistency of lubricating greases. The penetration force is determined by the mass of the cone and the shaft.

3.1.3 *thickener, n*—in lubricating grease, a substance composed of finely divided particles dispersed in a liquid lubricant to form the product's structure.

3.1.3.1 *Discussion*—The thickener can be fibers (such as

<sup>1</sup> These test methods are the jurisdiction of ASTM Committee D-2 on Petroleum Products and Lubricants and the IP Standardization Committee and are the direct responsibility of Subcommittee D02.G on Lubricating Grease.

Current edition approved Nov. 10, 1997. Published September 1998. Originally published as D 217 – 25 T. Last previous edition D 217 – 94.

<sup>2</sup> National Lubricating Grease Institute, 4635 Wyandotte St., Kansas City, MO 64112-1596.

<sup>3</sup> Annual Book of ASTM Standards, Vol 05.01.

various metallic soaps) or plates or spheres (such as certain non-soap thickeners) which are insoluble or, at most, only very slightly soluble in the liquid lubricant. The general requirements are that the solid particles be extremely small, uniformly dispersed, and capable of forming a relatively stable, gel-like structure with the liquid lubricant.

3.1.4 *lubricant, n*—any material interposed between two surfaces that reduces the friction or wear between them.

3.1.5 *consistency, n*—of lubricating grease, the degree of resistance to movement under stress.

3.1.5.1 *Discussion*—The term consistency is used somewhat synonymously with penetration. Generally, consistency refers to the worked penetration of a grease.

3.2 *Definitions of Terms Specific to This Standard:*

3.2.1 *penetrometer, n*—an instrument (see Fig. 1) designed to measure the depth to which the standard cone falls into the grease.

3.2.2 *penetration, n*—of lubricating grease, the depth that the standard cone (see A1.1), enters the sample when released to fall under its own weight for 5 s.

3.2.3 *unworked penetration, n*—of lubricating grease, the penetration at 25°C (77°F) of a sample that has received only minimum disturbance in transferring to a grease worker cup or dimensionally equivalent rigid container.

3.2.4 *working, n*—of lubricating grease, the subjection of a sample to the shearing action of the standard grease worker.

3.2.5 *worked penetration, n*—of lubricating grease, the penetration at 25°C (77°F), without delay, of a sample after 60 double strokes in a standard grease worker.

3.2.6 *prolonged worked penetration, n*—of lubricating grease, the penetration of a sample after it has been worked more than 60 double strokes in a standard grease worker at a temperature of 15 to 30°C (59 to 86°F).

3.2.6.1 *Discussion*—After the prescribed number of double strokes, the worker and contents are brought to 25°C (77°F), worked an additional 60 double strokes, and penetrated without delay.

3.2.7 *block penetration, n*—of lubricating grease, the penetration at 25°C (77°F) determined on the freshly prepared face of a cube cut from a sample that is sufficiently hard to hold its shape.

4. Summary of Test Methods

4.1 For unworked penetration, the sample is brought to 25°C (77°F) in a worker cup or other suitable container. The cone assembly of the penetrometer is released and allowed to drop freely into the grease for 5 s. Three determinations are made and averaged to give the reported result.

4.2 For worked penetration, the sample is brought to 25°C (77°F) and placed in the worker cup. The sample is subjected to 60 double strokes in the grease worker. The penetration is determined immediately by releasing the cone assembly from the penetrometer and allowing the cone to drop freely into the grease for 5 s. Three determinations are made and averaged to give the reported result.

4.3 For prolonged worked penetration, the sample is placed in the worker cup and subjected to a predetermined number of double strokes in the grease worker. Following completion of the prolonged working, the grease and worker assembly are brought to 25°C (77°F) and the grease is worked an additional 60 double strokes in the grease worker. The penetration is determined immediately by releasing the cone assembly from the penetrometer and allowing the cone to drop freely into the grease for 5 s. Three determinations are made and averaged to give the reported result.

4.4 For block penetration, a cube of the grease is prepared by slicing off a thin layer using the grease cutter. The cube of grease is brought to 25°C (77°F) and placed on the penetrometer table with the prepared face upward. The penetration is determined by releasing the cone assembly from the penetrometer and allowing the cone to drop freely into the grease for 5 s. Three determinations are made and averaged to give the reported result.

5. Significance and Use

5.1 These cone penetration tests not only evaluate the consistency of lubricating greases over the full range of NLGI numbers from 000 to 6, but also evaluate the consistency of stiff greases having penetration numbers less than 85. In contrast, Test Method D 937 is aimed at petrolatums and Test Method D 1403 uses less precise one-quarter and one-half scale equipment intended for use when the sample quantity is limited.

5.2 Cone penetration test results provide one measure of the consistency of a grease. Worked penetration results are required to determine to which NLGI consistency grade a grease belongs. Undisturbed penetration results provide a means of

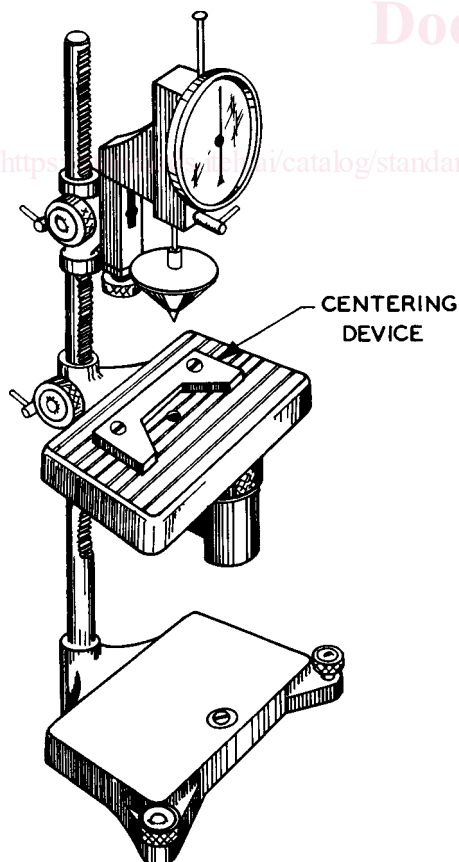

FIG. 1 Penetrometer

evaluating the effect of storage conditions on grease consistency.

5.3 Although no correlation has been developed between cone penetration results and field service, the cone penetrations obtained by the four procedures are widely used for specification purposes, such as in users' material specifications and suppliers' manufacturing specifications.

## 6. Apparatus

6.1 *Penetrometer*, in accordance with A1.1. The instrument shall be capable of indicating depth in tenths of a millimetre. A sketch of a generic penetrometer is shown in Fig. 1.

6.2 *Standard Penetrometer Cone*, in accordance with A1.2, is suitable for all penetrations. An optional penetrometer cone, in accordance with A1.3, is suitable only for penetrations less than 400. The optional cone should not be used to measure the penetration of 00 and 000 grade greases.

6.3 *Grease Worker*, comprising a grease cup, cover, and plunger assembly, in accordance with A1.4, constructed for either manual or mechanical operation.

6.3.1 *Grease Worker Drive, Manual*, in accordance with A1.5, which allows for working the grease at a rate of  $60 \pm 10$  double strokes per minute.

6.3.2 *Grease Worker Drive, Motorized*, in accordance with A1.6, which allows for working the grease at a rate of  $60 \pm 10$  double strokes per minute. This apparatus is essential for the working step of the prolonged worked penetration procedure.

6.4 *Grease Cutter*, in accordance with A1.7, is used for preparation of samples for block penetration.

6.5 *Temperature Bath*, either a water bath or an air bath capable of controlling the bath temperature at  $25 \pm 0.5^\circ\text{C}$  ( $77 \pm 1^\circ\text{F}$ ) and designed to bring the assembled grease worker to test temperature conveniently. If a water bath is to be used for samples for unworked penetration, means should be provided for protecting the grease surface from water and for maintaining the air above the sample at test temperature. An air bath is preferred for bringing block greases to test temperature, but a tightly sealed container placed in a water bath will suffice. A constant-temperature test room may be used instead of the temperature bath.

6.6 *Spatula*, corrosion-resistant, having a stiff blade 32 mm (1.25 in.) wide and at least 150 mm (6 in.) long.

6.7 *Temperature-Measuring Device*, with a sheath length of approximately 200 mm (8 in.) and a sheath diameter of approximately 3.7 mm (0.145 in.) (small enough to fit through the vent cock). The temperature range of the device should be wide enough to allow it to be immersed in grease at approximately  $38^\circ\text{C}$  ( $100^\circ\text{F}$ ) without damage. The scale should have small enough divisions (or digital resolution) to allow the user to read  $\pm 0.5^\circ\text{C}$  ( $\pm 1^\circ\text{F}$ ). A spacer can be applied to the upper portion of the sheath to hold the tip just above the perforated plate of the grease worker and in the bulk of the sample (see A1.3).

6.8 *Overflow Ring (optional)*, in accordance with A1.8, is a useful device for catching grease scraped from the sample surface as well as any grease forced by the penetrometer cone to overflow from the cup. This grease can be returned to the worker cup for subsequent testing.

## 7. Reagents and Materials

7.1 *Appropriate Volatile Gum-free Solvent*, for example, light petroleum naphtha.

7.2 *Cloth or Paper Wiper*, for wiping grease from the penetrometer cone. The wiper should be soft, so as not to scratch the cone.

## 8. Sampling

8.1 *Sample Size*—Sufficient sample (at least 0.4 kg (1 lb)) to overfill the cup of the standard grease worker is required. If the sample size is insufficient and penetration ranges from NLGI 0 to 4, use Test Method D 1403. If the full-scale penetration value calculated in Test Method D 1403 is above 200, at least three times the amount needed to fill the one-quarter or one-half scale worker cup is required.

8.1.1 For block penetration, obtain a sufficient size sample of the grease, which must be hard enough to hold its shape, to permit cutting from it a 50-mm (2-in.) cube as a test specimen.

8.2 *Sample Preparation*—Samples are prepared for the various cone penetration test methods as follows:

8.2.1 *Unworked Penetration*—Place the empty grease worker cup, or dimensionally equivalent rigid container, and an appropriate amount of the sample in a metal container in the temperature bath maintained at  $25^\circ\text{C}$  for sufficient time to bring the temperature of the sample and the worker cup to  $25 \pm 0.5^\circ\text{C}$  ( $77 \pm 1^\circ\text{F}$ ). If the initial sample temperature differs from  $25^\circ\text{C}$  by more than about  $8^\circ\text{C}$  ( $15^\circ\text{F}$ ), or if an alternative method of bringing the sample to  $25^\circ\text{C}$  is used, allow sufficient additional time to ensure that the specimen is at  $25 \pm 0.5^\circ\text{C}$  before proceeding. Also, if the sample is larger than 0.4 kg (1 lb), allow sufficient additional time to ensure that the specimen is at  $25 \pm 0.5^\circ\text{C}$ . Testing may proceed if the specimen is at a uniform temperature of  $25 \pm 0.5^\circ\text{C}$ . Transfer the specimen, preferably in one lump, to overfill the cup of the grease worker or other container. Make this transfer in such a manner that the grease will be worked as little as possible. Jar the cup to drive out trapped air and pack the grease with the spatula, with as little manipulation as possible, to obtain a cupful without air pockets. Scrape off the excess grease extending above the rim by moving the blade of the spatula, held inclined toward the direction of motion at an angle of  $45^\circ$ , across the rim of the cup (Fig. 2). Do not perform any further leveling or smoothing of the surface throughout the determination of unworked penetration and determine the measurement immediately.

8.2.1.1 The penetrations of soft greases are dependent upon the diameter of the container. Therefore, greases having unworked penetrations greater than 265 should be tested in containers having the same diameter limitations as those of the worker cup. The results on greases having penetrations less than 265 are not significantly affected if the diameter of the container exceeds that of the worker cup.

8.2.2 *Worked Penetration*—The following sections describe the procedure for preparation of samples for worked penetration:

8.2.2.1 *Working*—Transfer sufficient specimen to the cup of the clean grease worker to fill it heaping full (mound up about 13 mm (0.5 in.) at the center), avoiding the inclusion of air by packing with the spatula. Jar the cup from time to time as it is



FIG. 2 Preparing Sample for Penetration Measurement

being packed to remove any air inadvertently entrapped. Assemble the worker and, with the vent cock open, depress the plunger to the bottom. Insert a thermometer through the vent cock so that its tip is in the center of the grease. Place the assembled worker in the temperature bath maintained at  $25^{\circ}\text{C}$  ( $77^{\circ}\text{F}$ ) (Note 2) until the temperature of the worker and its contents is  $25 \pm 0.5^{\circ}\text{C}$  as indicated by the thermometer. If the initial sample temperature differs from  $25^{\circ}\text{C}$  by more than about  $8^{\circ}\text{C}$  ( $15^{\circ}\text{F}$ ), or if an alternative method of bringing the sample to  $25^{\circ}\text{C}$  is used, allow sufficient additional time to ensure that the specimen is at  $25 \pm 0.5^{\circ}\text{C}$  before proceeding. Also, if the sample is larger than 0.4 kg (1 lb), allow sufficient additional time to ensure that the specimen is at  $25 \pm 0.5^{\circ}\text{C}$ . Testing may proceed when the specimen is at a uniform temperature of  $25 \pm 0.5^{\circ}\text{C}$ . Remove the worker from the bath. If a water bath was used, wipe any excess water from the outer surfaces of the worker. Remove the thermometer and close the vent cock. Subject the grease to 60 full (67 to 71.5 mm ( $2\frac{5}{8}$  to  $2\frac{13}{16}$  in.)) double strokes of the plunger, completed in about 1 min, and return the plunger to its top position. Open the vent cock, remove the cover and plunger, and return to the cup as much of the grease clinging to the plunger as can readily be removed.

NOTE 2—If it is desired to immerse the worker above the joint between the cup and cover, take care that the joint is watertight in order to prevent the entrance of water to the worker.

8.2.2.2 *Preparing Sample for Measurement*—Jar the cup sharply on the bench or floor and pack the grease down with a spatula to fill the holes left by the plunger and to remove any air pockets (Note 3). Scrape off the excess grease extending over the rim by moving the blade of the spatula, held inclined toward the direction of motion at an angle of  $45^{\circ}$ , across the rim of the cup (Fig. 2), retaining the portion removed (Note 4).

NOTE 3—The jarring should be only as vigorous as required to remove the entrapped air without splashing the specimen from the cup. In performing these operations, a minimum of manipulation should be used, as any agitation of the grease may have the effect of increasing the working beyond the specified 60 strokes.

NOTE 4—Particularly when testing soft greases, retain the grease removed from the cup in scraping to provide a full cup for subsequent

tests. Keep the outside of the rim of the cup clean so that the grease forced by the penetrometer cone to overflow the cup may be returned to the cup prior to preparing the specimen for the next test.

8.2.3 *Prolonged Worked Penetration*—Fill a clean grease worker cup and assemble the worker as described in 8.4.2. Subject the grease specimen to the prescribed number of double strokes (Note 5). Immediately after the working is concluded, place the worker in the temperature bath to bring the test specimen temperature to  $25 \pm 0.5^{\circ}\text{C}$  ( $77 \pm 1^{\circ}\text{F}$ ) within 1.5 h. Remove the worker from the temperature bath and subject the grease to a further 60 full (67 to 71.5 mm ( $2\frac{5}{8}$  to  $2\frac{13}{16}$  in.)) double strokes of the plunger, completed in about 1 min, and return the plunger to its top position. Open the vent cock, remove the cover and plunger, and return to the cup as much of the grease clinging to the plunger as can readily be removed. Jar the cup sharply on the bench or floor and pack the grease down with a spatula to fill the holes left by the plunger and to remove any air pockets (Note 3). Scrape off the excess grease extending over the rim by moving the blade of the spatula, held inclined toward the direction of motion at an angle of  $45^{\circ}$ , across the rim of the cup (Fig. 2), retaining the portion removed (Note 4).

NOTE 5—In order to minimize leakage during working, special attention should be paid to the seal in the worker cover.

8.2.3.1 *Temperature*—Maintain the temperature of the room used for the test within the range from 15 to  $30^{\circ}\text{C}$  (59 to  $86^{\circ}\text{F}$ ). No further control of the worker temperature is necessary; but, before starting the test, the grease should have been in the room for sufficient time to bring its temperature within the range from 15 to  $30^{\circ}\text{C}$ .

8.2.4 *Block Grease*—By means of the specified grease cutter, cut as a test specimen from the sample at room temperature a cube about 50 mm (2 in.) on the edge (Fig. 3(a)). While holding this specimen so that the unbeveled edge of the cutter is toward it (Fig. 3(b)), slice off a layer about 1.5 mm ( $\frac{1}{16}$  in.) in thickness from each of the three faces adjacent to a single corner, which can be truncated for identification (Fig. 3(c) and Note 6). Take care not to touch those portions of the newly exposed faces which are to be used for testing or to set

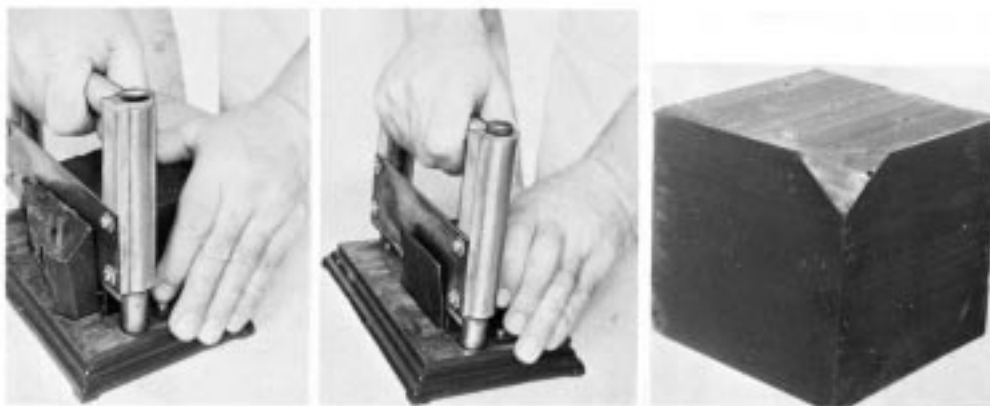

FIG. 3 Preparing Block Sample for Penetration Measurement

a prepared face against the base plate or guide of the cutter. Bring the temperature of the prepared specimen to  $25 \pm 0.5^\circ\text{C}$  ( $77 \pm 1^\circ\text{F}$ ) by placing it in a temperature bath maintained at  $25^\circ\text{C}$  ( $77^\circ\text{F}$ ) for at least 1 h. If the initial sample temperature differs from  $25^\circ\text{C}$  by more than about  $8^\circ\text{C}$  ( $15^\circ\text{F}$ ), or if an alternative method of bringing the sample to  $25^\circ\text{C}$  is used, allow sufficient additional time to ensure that the specimen is at  $25 \pm 0.5^\circ\text{C}$  ( $77 \pm 1^\circ\text{F}$ ) before proceeding.

NOTE 6—The testing of three faces is intended to equalize in the final value the effect of fiber orientation in testing fibrous greases. Smooth-textured, nonfibrous greases can be tested on one face only, when agreed upon between the interested parties.

## 9. Preparation of Apparatus

9.1 *Cleaning Penetrometer Cone*—Clean the penetrometer cone carefully before each test with a soft cloth or paper wiper. The wiper can be dampened with an appropriate volatile gum-free solvent, when necessary, to remove any grease remaining on the cone. The solvent should have no effect on the cone surface. While cleaning, do not rotate the cone, as this can cause wear on the release mechanism. Bending of the cone shaft can be avoided by holding the cone securely in its raised position while cleaning.

9.2 *Cleaning Penetrometer Shaft*—The penetrometer shaft should be cleaned periodically with a soft cloth or paper wiper dampened with an appropriate volatile gum-free solvent to remove any oil, grease, or dirt buildup. Foreign materials on the penetrometer shaft can cause drag on the shaft assembly, possibly causing erroneous results.

9.3 Any other cleaning or adjustments to the apparatus should be done in accordance with the equipment manufacturer's recommendations.

## 10. Calibration and Standardization

10.1 Proper operation of a grease penetrometer can be checked by running periodic tests with a grease of known consistency. NLGI<sup>2</sup> reference grease has been found to be suitable for this purpose, since multiple laboratories run tests on this material to generate the data reported for it. Data on this material is provided by NLGI with the purchase of the grease.

## 11. Procedure

11.1 *Unworked Penetration*—Place the cup on the pen-

etrometer table, making certain that it cannot teeter. Set the mechanism to hold the cone in the zero position, and adjust the apparatus carefully so that the tip of the cone just touches the surface at the center of the test specimen. Watching the shadow of the cone tip, from a low angle with backlighting, is an aid to accurate setting. For greases with penetrations over 400, the cup must be centered to within 0.3 mm (0.01 in.) of the tip of the cone. One way to center the cup accurately is to use a centering device (Fig. 1). Release the cone shaft rapidly, and allow it to drop for  $5.0 \pm 0.1$  s. The release mechanism should not drag on the shaft. Lock the shaft in position at the end of the 5-s period. Gently depress the indicator shaft until stopped by the cone shaft and read the penetration from the indicator.

11.1.1 If the sample has a penetration over 200, center the cone carefully in the cup; this sample can then be used for only one test. If the sample has a penetration of 200 or less, perform three tests in a single cup, spacing these tests on three radii  $120^\circ$  apart and midway between the center side of the cup so that the cone will neither strike the side of the container nor impinge on the disturbed area made in a previous test.

11.1.2 *Additional Tests*—Make a total of three tests on the specimen (either in three cups or in one, in accordance with 11.1.1), and report the average of the three tests, to the nearest 0.1 mm, as the unworked penetration of the specimen.

11.2 *Worked Penetration*—Determine the penetration of the specimen in accordance with 11.1.

11.2.1 *Additional Tests*—Immediately make two more tests in succession on the same specimen. Return to the cup the portion previously removed with the spatula, then repeat the operations in accordance with 8.4.2.2. Report the average of the three tests, to the nearest 0.1 mm, as the worked penetration of the specimen.

11.3 *Prolonged Worked Penetration*—Determine the penetration of the specimen in accordance with 11.1.

11.3.1 *Additional Tests*—Immediately make two more tests in succession on the same specimen. Return to the cup the portion previously removed with the spatula, then repeat the operations in accordance with 8.4.2.2. Report the average of the three tests, to the nearest 0.1 mm, as the prolonged worked penetration of the specimen.

11.4 *Block Penetration*—Place the test specimen on the penetrometer table with one of the prepared faces upward, and

 **D 217**

press it down by the corners to make it rest level and firmly on the table so that it cannot teeter during the test. Set the mechanism to hold the cone in the zero position, and adjust the apparatus carefully so that the tip of the cone just touches the surface at the center of the test sample. Determine the penetration in accordance with 11.1. Make a total of three tests on the exposed face of the specimen, locating the tests at least 6 mm (¼ in.) from the edge and as far apart as possible without impinging on any touched portion, air hole, or other apparent flaw in the surface. If the result of one of these tests differs from the others by more than three units, make additional tests until three values agreeing within three units are obtained. Average these three values for the face being tested.

11.4.1 *Additional Tests*—Repeat the procedure described in 11.4 on each of the other prepared faces of the specimen. Report one third of the sum of the averages for the three faces, to the nearest 0.1 mm as the block penetration of the specimen.

**12. Report**

12.1 Report the following information:

12.1.1 *Unworked Penetration*—Report the average value obtained in 11.1.2 as the unworked penetration of the grease under test.

12.1.2 *Worked Penetration*—Report the average value obtained in 11.2.1 as the worked penetration of the grease under test.

12.1.3 *Prolonged Worked Penetration*—Report the average value obtained in 11.3.1 as the prolonged worked penetration of the grease under test. The number of double strokes to which the grease was subjected during the prolonged working shall also be reported.

12.1.4 *Block Penetration*—Report the value obtained in 11.4.1 as the block penetration of the grease under test.

**13. Precision and Bias**

13.1 *Precision*—The precision of these test methods is based on work done by the Institute of Petroleum. Their

precision evaluation is considered to conform to the requirements of Committee D-2, RR:D02-1007, Manual on Determining Precision Data for ASTM Test Methods on Petroleum Products and Lubricants.<sup>3</sup>

13.2 The precision of these test methods as determined by statistical examination of interlaboratory results is as follows:

13.2.1 *Repeatability*—The difference between two test results obtained by the same operator with the same apparatus under constant operating conditions on identical test material would, in the long run, in the normal and correct operation of the test method, exceed the values in Table 1 in only one case in twenty.

13.2.2 *Reproducibility*—The difference between two single and independent results obtained by different operators working in different laboratories on identical test material would, in the long run, in the normal and correct operation of the test method, exceed the values in Table 1 in only one case in twenty.

13.3 *Bias*—The procedure in Test Methods D 217 for measuring cone penetration of lubricating greases has no bias because the value of cone penetration is defined only in terms of these test methods.

**14. Keywords**

14.1 consistency; grease; lubricating grease; penetration; penetrometer; worked penetration

**TABLE 1 Repeatability and Reproducibility**

Penetration	Penetration Range	Repeatability, One Operator and Apparatus	Reproducibility, Different Operators and Apparatus
Unworked	85 to 475	8 units	19 units
Worked	130 to 475	7 units	20 units
Prolonged worked	130 to 475	15 units <sup>A</sup>	27 units <sup>A</sup>
Block	under 85	7 units	11 units

<sup>A</sup>Determined at 100 000 double strokes within 15 to 30°C (59 to 86°F) ambient temperature range.

**ANNEX**

**(Mandatory Information)**

**A1. APPARATUS**

A1.1 *Penetrometer*, similar to the instrument illustrated in Fig. 1, designed to measure in tenths of a millimetre the depth to which the standard (or optional) cone falls into the grease. The cone assembly or the table of the penetrometer shall be adjustable to enable accurate placement of the tip of the cone on the level surface of the grease while maintaining a zero reading on the indicator. When released, the cone should fall without appreciable friction. Both the penetrometer shaft and the rack engaging the measuring dial should be at least 62.0 mm in length. If only penetrations less than 400 are to be measured, the penetrometer may be designed such that, when released, the cone falls for at least 40.0 mm. The tip of the cone should not hit the bottom of the sample container. The

instrument shall be provided with leveling screws and a spirit level to maintain the cone shaft in a vertical position.

A1.1.1 *Automatic Penetrometers*, which include such devices as timers, electrical release mechanisms, digital depth indicators, and contact sensors are permitted, so long as the results obtained with such instruments are shown to fall within the precision in accordance with 13.2.

A1.2 *Standard Cone*, for measuring penetrations up to 475, consisting of a conical body of magnesium or other suitable material with detachable, hardened steel tip, shall be constructed to conform to the tolerances in accordance with Fig. A1.1. The total mass of the cone shall be 102.5 ± 0.05 g and