



Designation: D3245 – 03

Standard Test Method for Pumpability of Industrial Fuel Oils¹

This standard is issued under the fixed designation D3245; the number immediately following the designation indicates the year of original adoption or, in the case of revision, the year of last revision. A number in parentheses indicates the year of last reapproval. A superscript epsilon (ϵ) indicates an editorial change since the last revision or reapproval.

1. Scope*

1.1 This test method is intended for use on petroleum fuel oils, such as those covered in Specification D396 Grade No 4(Light), 4, 5(Light), 5, and 6, or similar fuels.

1.2 The values stated in SI units are to be regarded as standard. The values in parentheses are for information only.

1.3 *This standard does not purport to address all of the safety concerns, if any, associated with its use. It is the responsibility of the user of this standard to establish appropriate safety and health practices and determine the applicability of regulatory limitations prior to use.*

2. Referenced Documents

2.1 *ASTM Standards:*²

D396 Specification for Fuel Oils²

D445 Test Method for Kinematic Viscosity of Transparent and Opaque Liquids (and Calculation of Dynamic Viscosity)³

E1 Specification for ASTM Liquid-in-Glass Thermometers

3. Terminology

3.1 *Definitions:*

3.1.1 *handling point*—an indication of the minimum temperature to which an oil should be heated in any part of the suction or delivery line of an oil-handling installation when the installation is operating. If the storage tank does not contain an outflow heater, this temperature is necessarily the minimum oil storage temperature.

3.1.2 It is defined as that temperature at which the oil has an apparent viscosity of 0.6 Pa·s (6 P), at a rate of shear of 9.7 s⁻¹, when cooled and tested under prescribed conditions.

3.1.3 *storage point*—an indication of the minimum temperature to which an oil should be heated in any part of an oil-handling installation when starting up after a shutdown. It is also an indication of the minimum temperature at which the oil should be stored in a tank fitted with an outflow heater.

3.1.4 It is defined as that temperature at which the oil has an apparent viscosity of 2.5 Pa·s (25 P), at a rate of shear of 9.7 s⁻¹, when cooled and tested under prescribed conditions.

4. Summary of Test Method

4.1 A sample of the oil, preheated if necessary to a specified temperature to make it fluid, is poured into the cup of the portable viscometer. This is immersed in a bath at a predetermined temperature. After 15 min, the viscometer is started at a rate of shear of 9.7 s⁻¹. After a further 5 min, the bath is cooled at 0.5°C/min (1°F/min). The temperatures at which apparent viscosities of 0.6 Pa·s (6 P) and 2.5 Pa·s (25 P) are obtained are determined.

5. Significance and Use

5.1 This test method is designed to give an indication of the minimum storage and minimum handling temperatures which may be used for a given fuel oil. This test method is cited in Specification D396.

6. Apparatus

6.1 *Temperature Measuring Device*—conforming to specifications for ASTM thermometers 63C, 64C, and 12C, or equivalent, in accordance with Specification E1, or any other temperature measuring device with equal or better accuracy and equal temperature response.

6.2 *Oil Container*, made of aluminum or aluminum alloy to the dimensions given in Fig. 1A and B. The cup (Fig. 1A) is a loose fit on the Model VW outer cylinder of the viscometer. The inner diameter of the cup shall not exceed the outside diameter of the viscometer outer cylinder by more than 0.4 mm or less than 0.15 mm. The cup has four grooves in the side to allow easy flow of oil past the outer viscometer cylinder; these

¹ This test method is under the jurisdiction of ASTM Committee D02 on Petroleum Products and Lubricants and is the direct responsibility of Subcommittee D02.07 on Flow Properties.

Current edition approved March 10, 2003. Published May 2003. Originally approved in 1973. Last previous edition approved in 1996 as D3245-96.

This test method is based on IP 230 but contains a precision statement based on an ASTM/IP round robin using waxy and non-waxy fuel oils typical of those marketed in North America. DOI: 10.1520/D3245-03.

² *Annual Book of ASTM Standards*, Vol 05.01.

³ *Annual Book of ASTM Standards*, Vol 14.03.

*A Summary of Changes section appears at the end of this standard.

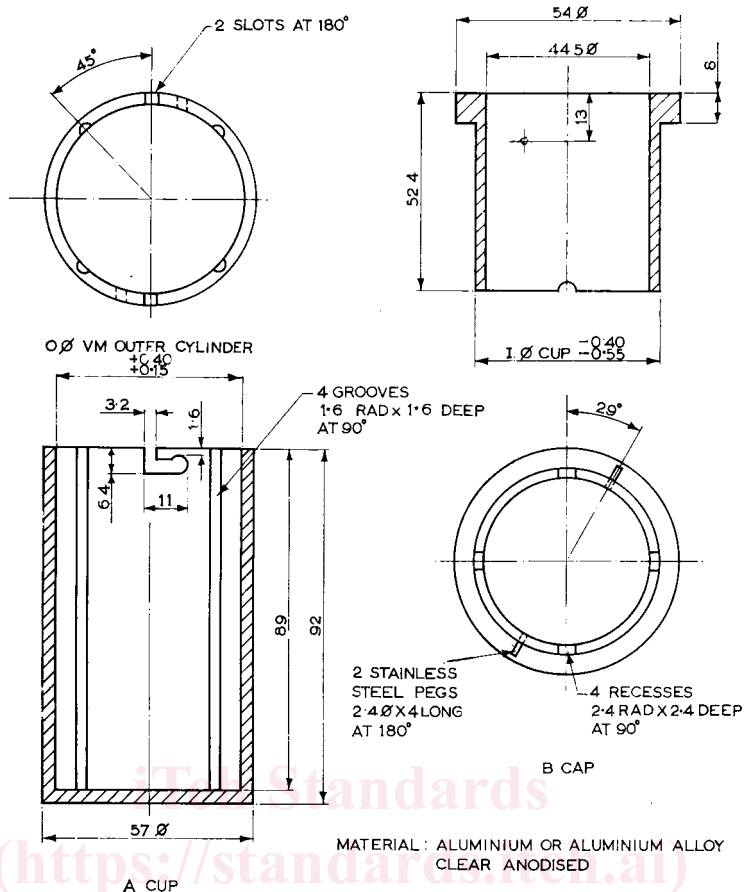

FIG. 1 Details of Oil Container for Viscosity Determinations

align with four recesses in the cap (Fig. 1B) when in position. The cap supports the viscometer cup to which it is secured by a bayonet fitting.

6.3 *Three-Speed Portable Viscometer Model VH*,⁴ fitted with a 2 mN·m (20 gf·cm) spring and a Model VM outer cylinder having a plastic shaft and B inner cylinder (Fig. 2). A viscometer should be selected having a Multiplying Factor, that is, a viscometer factor, of not less than 0.25 P per division.

6.3.1 Four 5-mm (3/16-in.) holes are drilled symmetrically into the top of both the Model VM outer cylinder and guard ring, to allow oil to flow easily into the gap between the cylinders.

6.4 *Water Bath*, of any convenient size or shape such that the oil container can be immersed in it and the Ferranti viscometer can be placed in an operating position with the container in the bath. The bath shall be capable of being maintained at a temperature of 82 ± 1°C (180 ± 2°F).

6.5 *Water Bath*, similar to 6.4 which can be maintained at 10, 20, 30, 40, 50, and 55 ± 0.5°C. The bath must also be capable of being cooled at 0.5°C/min (1°F/min) to 2°C (35°F)

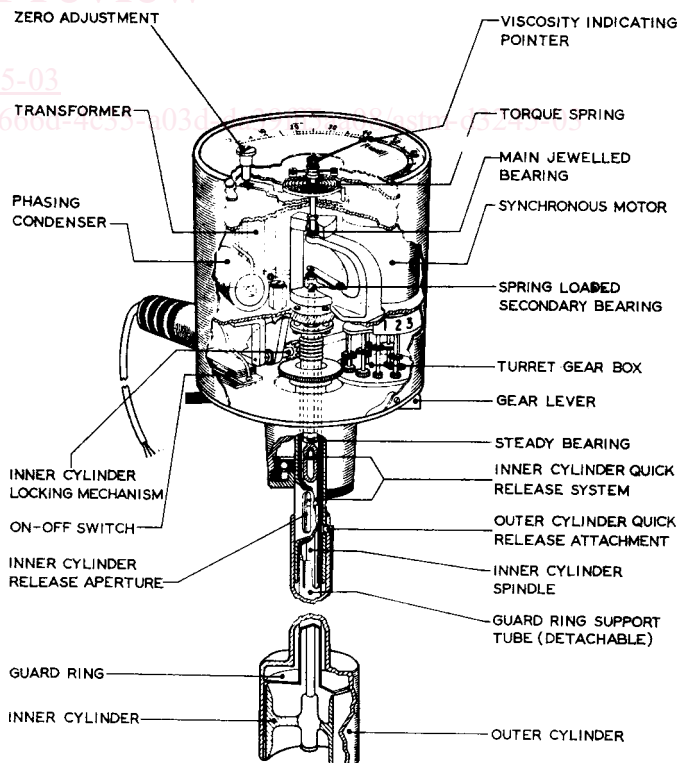

FIG. 2 3-Speed Portable Viscometer Model VH

⁴ The sole source of supply of the apparatus known to the committee at this time is Ravenfield Designs, Ltd., Russell St., Heywood, Lancs., OL10 1NX, England. If you are aware of alternative suppliers, please provide this information to ASTM Headquarters. Your comments will receive careful consideration at a meeting of the responsible technical committee,¹ which you may attend.