



Designation: E 644 – 02

## Standard Test Methods for Testing Industrial Resistance Thermometers<sup>1</sup>

This standard is issued under the fixed designation E 644; the number immediately following the designation indicates the year of original adoption or, in the case of revision, the year of last revision. A number in parentheses indicates the year of last reappraisal. A superscript epsilon ( $\epsilon$ ) indicates an editorial change since the last revision or reappraisal.

### 1. Scope

1.1 These test methods describe the principles, apparatus, and procedures for calibration and testing of industrial resistance thermometers.

1.2 These test methods cover the tests for insulation resistance, calibration, immersion error, pressure effects, thermal response time, vibration effect, mechanical shock, self-heating effect, stability, thermoelectric effect, humidity, thermal hysteresis and thermal shock.

1.3 These test methods are not necessarily intended for, recommended to be performed on, or appropriate for every type of thermometer. The expected repeatability and reproducibility of the results are tabulated in Appendix X4.

1.4 These test methods, when specified in a procurement document, shall govern the method of testing the resistance thermometer.

1.5 Thermometer performance specifications, acceptance limits, and sampling methods are not covered in these test methods; they should be specified separately in the procurement document.

1.6 *This standard does not purport to address all of the safety concerns, if any, associated with its use. It is the responsibility of the user of this standard to establish appropriate safety and health practices and determine the applicability of regulatory limitations prior to use.* Specific precautionary statements are given in 6.3.2, 6.3.5, and 8.1.

### 2. Referenced Documents

#### 2.1 ASTM Standards:

E 77 Test Method for the Inspection and Verification of Thermometers<sup>2</sup>

E 230 Temperature-Electromotive Force (EMF) Tables for Standardized Thermocouples<sup>2</sup>

E 344 Terminology Relating to Thermometry and Hydrometry<sup>2</sup>

E 563 Practice for Preparation and Use of Freezing Point Reference Baths<sup>3</sup>

E 1137 Specification Industrial Platinum Resistance Thermometers<sup>2</sup>

E 1502 Guide for Use of Freezing-Point Cells for Reference Temperatures<sup>2</sup>

E 1750 Guide for Use of Water Triple Point Cells<sup>2</sup>

E 1751 Guide to Temperature Electromotive Force (EMF) Tables for Non-Letter Designated Thermocouple Combinations<sup>2</sup>

#### 2.2 Military Standard:

MIL-STD-202 Test Methods for Electronic and Electrical Component Parts<sup>4</sup>

### 3. Terminology

#### 3.1 Definitions:

3.1.1 The definitions given in Terminology E 344 shall apply to these test methods.

### 4. Significance and Use

4.1 These test methods provide uniform methods for testing industrial resistance thermometers so that a given tester may expect to obtain the same value of a test result from making successive measurements on the same test article within the limits of repeatability given in Appendix X4. Independent testers may also expect to obtain the same result from the testing of the same article within the limits of reproducibility given in Appendix X4.

4.2 These tests may be used to qualify platinum resistance thermometers for use in specific applications to meet a particular specification such as Specification E 1137, or to evaluate relative merits of equivalent test articles supplied by one or more manufacturers, or to determine the limits of the application of a particular design of thermometer.

4.3 The expected repeatability and reproducibility of selected test methods are included in Appendix X4.

4.4 Some non-destructive tests described in these test methods may be applied to thermometers that can be subsequently

<sup>1</sup> These test methods are under the jurisdiction of ASTM Committee E20 on Temperature Measurement and are the direct responsibility of Subcommittee E20.03 on Resistance Thermometers.

Current edition approved October 10, 2002. Published April 2003. Originally published as E 644-78. Last previous edition E 644-98.

<sup>2</sup> *Annual Book of ASTM Standards*, Vol 14.03.

<sup>3</sup> Discontinued; see 1996 *Annual Book of ASTM Standards*, Vol 14.03.

<sup>4</sup> Available from Superintendent of Documents, U.S. Government Printing Office, Washington, DC 20234.

sold or used; other destructive tests may preclude the sale or use of the test article because of damage that the test may produce.

## PROCEDURES

### 5. Insulation Resistance Test

5.1 *Scope*—The insulation resistance between the thermometer element with its connecting wires and its external shield, case or means for mounting, should be sufficient to prevent significant electrical shunting or ground loop current in the measurement circuit, or any circuit failure if the excitation source is grounded. This test assumes that the thermometer has a metallic or other electrically conductive sheath or housing. The most probable factors that contribute to insulation failure are contamination, typically from moisture, and mechanical breakdown due to physical damage to the device. Most ceramic oxide insulation absorbs moisture. This moisture is expected to migrate inside the thermometer, depending upon the temperature condition of use, and to cause variations in the insulation resistance. Test conditions for insulation resistance should therefore approximate the most severe conditions of probable use and shall be specified as a minimum at a specific temperature, humidity, pressure and test voltage. It is recommended that insulation resistance be measured using forward and reversed polarity on applied dc voltages. The test methods customarily applied with the test article at room temperature may also be employed to determine the insulation resistance at temperatures up to the rated application temperature for the resistance thermometer. This is intended to be a non-destructive test.

5.1.1 The insulation resistance, as measured between the lead wires and case, does not represent the shunt resistance in parallel with the sensing element. Therefore, this test should not be used to estimate temperature measurement errors caused by inadequate insulation resistance across the sensing element.

#### 5.2 Apparatus:

5.2.1 Because the insulation resistance is to be measured in conjunction with other tests, the thermometer shall be mounted as required for these tests.

5.2.2 Any equipment made for the purpose of insulation resistance testing shall be capable of measuring a resistance of at least 10 gigohms ( $10^{10} \Omega$ ) at the specified test voltage.

NOTE 1—**Caution:** Some instruments designed for insulation resistance testing are capable of producing lethal voltages (100 volts or greater) at their measuring terminals. Such instruments should have warning labels and used only by supervised and well trained personnel.

#### 5.3 Measurement Procedure:

5.3.1 Make check measurements on a reference resistor of 10 gigohms ( $10^{10} \Omega$ ). Check the measurement instrument to  $\pm 5\%$  at the required minimum insulation resistance using a certified reference resistor. These results should accompany the test report on the platinum resistance thermometer (PRT). For example: When testing a PRT with a specified 100 megohm ( $10^8 \Omega$ ) minimum insulation resistance, the meter should be tested with a resistor that has a certified resistance of 100 megohms  $\pm 5\%$ .

5.3.2 Make insulation resistance measurements between the connecting wires and the shield or case (1) before the ther-

mometer is subjected to the conditions of any concurrent test (calibration, pressure, vibration), (2) during the test, and (3) immediately after the thermometer has returned to ambient conditions. All measured values of insulation resistance for each test condition shall exceed the minimum specified value.

5.3.3 Apply the specified measuring voltage between the joined connecting wires and the thermometer sheath or between circuits that are intended to be isolated. Take measurements with normal and reversed polarity and record the lower reading. Take the reading within 10 s of voltage application. Since only minimum values of insulation resistance are of concern, measurement accuracy need only be sufficient to ensure that the minimum requirement is met. Insulation resistance measurements made during vibration require a high speed indicating device, such as an oscilloscope, to detect rapid transient changes in resistance.

5.4 The repeatability of the measurement's value is expected to be  $\pm 5\%$  and the reproducibility  $\pm 10\%$ . See Appendix X4 for the results of round robin testing used to determine the repeatability and reproducibility of this test.

### 6. Thermometer Calibration

6.1 *Scope*—This test method covers recommended ways of calibrating industrial resistance thermometers. Methods common to most calibrations will be described, but the test methods presented do not usually test the thermometer under the actual conditions of use. The heat transfer conditions can vary widely, depending upon the medium, immersion length, rate of flow of the medium, etc. These and other conditions should be carefully evaluated before installing a thermometer for calibration or for temperature measurement. A resistance thermometer can be calibrated by using the comparison method or the fixed-point method, or both. The calibration results may be used to assess interchangeability, to establish a unique resistance-temperature relationship for the thermometer under test, or to verify conformance to a standard. In calibration tests, care should be taken to minimize thermal shock to the thermometer when inserting it into a heated or cooled environment, or when withdrawing it from a furnace or heated bath. Transitions should be made slowly, preheating or pre-cooling the thermometer when possible. This test is intended to be a non-destructive test. However, calibration of a thermometer to a higher temperature than it has previously experienced may change its calibration at lower temperatures. Resistances taken at ascending temperatures should be compared with those taken at descending temperatures to detect any change in the thermometer's characteristics (see Section 16, Thermal Hysteresis).

#### 6.2 Calibration Methods:

6.2.1 *Comparison Method*—This method consists of measuring the resistance of the test thermometer in an isothermal medium, the temperature of which is determined by a calibrated reference thermometer. The reference thermometer may be a thermocouple, a liquid-in-glass thermometer, a resistance thermometer, or another thermometer of sufficient accuracy that has been calibrated by an approved method.

6.2.2 *Fixed-Point Method*—This method consists of measuring the resistance of the thermometer at the temperature defined by the equilibrium state between different phases of a

pure substance or a mixture of pure substances. Each fixed point provides a calibration of the test thermometer at only one temperature defined by suitable equilibrium phases. The temperature is an intrinsic property of a properly specified equilibrium state of a substance, such as the freezing point at 1 atm. The temperature of some fixed-point devices can be repeated to  $\pm 0.1$  m°C or better.

### 6.3 Apparatus and Procedure:

**6.3.1 Ice-Point Bath**— The most widely used and simplest fixed point is the ice-point. The ice point (0°C) may be realized with an error of less than 0.01°C if properly prepared and used. Significantly greater errors may be realized if certain conditions exist. Users of this test method are referred to Practice E 563 which contains a more detailed discussion as to the proper preparation and use of ice point baths.

**6.3.2 Freezing Points**— In addition to the ice-point bath, the freezing-point temperature of various substances can be used as fixed points. The metal freezing point materials identified in Guide E 1502 are those most commonly employed.

**6.3.3 Triple Point of Water**—The triple point of water is a commonly used thermometric fixed point used for calibrating thermometers. To accurately realize the triple point of water, a triple point of water cell is used. This cell must be prepared and handled in a specific manner. The user is directed to Guide E 1750 for the preparation and use of water triple point cells.

**6.3.4 Fluid Baths**— Control the temperature of fluid baths by adjusting the amount of heating or cooling while agitating the bath fluid. Determine the amount of heating or cooling by the indication of a sensitive thermometer in the bath. Table 1 lists some of the common bath media and their useful ranges of operating temperatures. The bath medium must be chemically stable at the operating temperatures and be inert to the bath container and the thermometer material. The bath temperature must be stable with time and uniform over the working space

at the operating temperatures. To test the stability of the bath, insert a reference thermometer into the working space of the bath and record the temperature as a function of time. The variations of the readings indicate the limit of stability of the bath. To test the temperature uniformity of the bath, while keeping the position of the first reference thermometer fixed in the working space of the bath, insert a second reference thermometer into various positions in the bath and determine the temperature relative to that of the first reference thermometer. The variations indicate the degree of temperature uniformity of the bath. A copper, aluminum, or other compatible metallic block immersed completely and suspended in the bath fluid can be more stable and uniform in temperature than the bath. Such an arrangement with wells for thermometers in the block are suitable for calibrating thermometers. To determine the qualification of the block for the work, follow the procedure described above for fluid baths. The calibration procedure can be made convenient by controlling the bath temperature using a standard thermometer or with a working thermometer that has been calibrated at the various control points in terms of a standard thermometer.

**NOTE 2—Caution:** Fluids may be easily ignited above their flash points. Fluids above 100°C may erupt violently if water or wet objects are placed in them. Care should be taken when handling corrosive, toxic, or hazardous liquids and vapors.

**6.3.4.1 Water Baths**— Water baths are satisfactory in the temperature range between 0 and 100°C (see Test Method E 77). Some baths are available that combine the basic ideas shown in Test Method E 77 with pumps so that the bath fluid may be circulated to heat or cool an external bath. Many commercially available baths have self-contained heaters, cooling coils, stirrers, and temperature controllers.

**6.3.4.2 Salt Baths**—In the range of temperatures between 200 and 620°C, salt baths are useful. A salt bath and procedures for its use are described in Test Method E 77. Salt baths for calibrating thermometers are commercially available. Some salt baths, designed primarily for heat treating metals and other materials, may be useful for calibrating thermometers.

**NOTE 3—Caution:** Molten salt will react violently if water comes in contact with it (see the caution statement in Note 2). While some salts will etch glass, some freshly prepared salt baths may also require removal of corrosive components.

**6.3.4.3 Refrigerated Baths**—In the range of temperatures below ambient, baths may be cooled by mechanical refrigeration or by cryogenics. The choice of fluids for such baths will be influenced by the temperature range. Means should be incorporated in the experimental design to avoid moisture condensation. There is some discussion on refrigerated bath fluids in Test Method E 77.

**NOTE 4—Caution:** Some of these fluids are flammable at room temperature and some give off poisonous vapors. They must be handled with care and operating in a hooded area is recommended.

**6.3.4.4 Vapor Baths**— A vapor bath may be used below 0°C. (While the method is usable to temperatures in excess of 100°C, it is more convenient to employ other types of baths.) Fig. 1 shows a typical vapor bath. An isothermal block houses the test thermometer and the standard thermometer. An electric

**TABLE 1 Fluid Bath Media and Typical Operating Temperature Range**

Media	Temperature Range, °C
Halogen (CH Comp. Mixtures)	-150 to -70
Silicone Oils	-100 to 315 <sup>A</sup>
Light Mineral Oils	-75 to 200 <sup>A</sup>
Water	0 to 100
GIT (gallium-62.5 %; 2000 <sup>B,C</sup>	15 to
indium-21.5 %; tin-16 %)	
Dry Fluids (Fluidized Particle Bed)	75 to 850 <sup>A</sup>
Molten Salts	200 to 620 <sup>A,D</sup>
Liquid Tin	315 to 540 <sup>A</sup>

<sup>A</sup> Fluids above 100°C may react violently if water or a wet object is immersed into them.

<sup>B</sup> GIT does not boil until approx. 2000°C, however it may attack some materials because it wets and removes oxide surfaces. Aluminum and silver are eroded slowly at room temperature and rapidly above 100°C. 304 and 316 stainless steel has been in contact with GIT in air at 406°C for 520 days without damage. Maximum temperature when in contact with 304 or 316 SST should be 650°C.

<sup>C</sup> GIT, which is molten at room temperature and silvery colored, superficially resembles mercury. If these two liquids are inadvertently mixed together, a violent exothermic reaction will occur which is definitely hazardous. GIT can be distinguished from mercury as it readily wets glass containers whereas mercury does not wet glass and displays a characteristic meniscus at the interface. Proper labels should be applied to containers of the eutectic. "DO NOT MIX WITH MERCURY."

<sup>D</sup> Some freshly prepared salt baths may require removal of corrosive components. Some salts will etch glass.



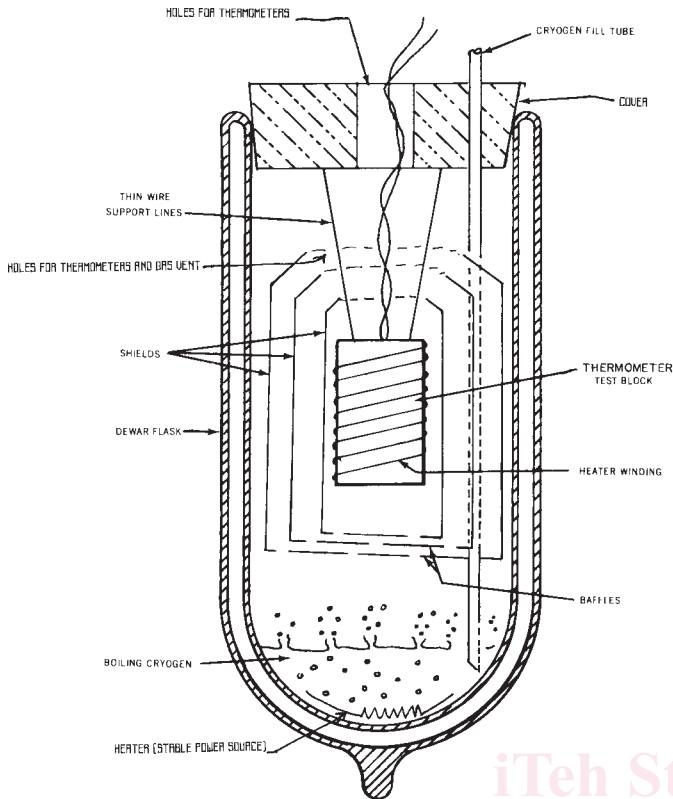

FIG. 1 Typical Vapor Bath

heater is wound on the surface of the block. Vaporizing a cryogen (usually liquid nitrogen) will enable the vapors to cool the block. Apply a few milliwatts of power to the block to raise its temperature to the desired value for the calibration. Usually an electronic controller is used to stabilize the temperature of the block. A stable power supply is required to provide a constant boil-off rate of the cryogen. Depending on the size of the block, the number of test thermometers, and the heat conduction down the supports or connecting wires, radiation and convection baffles may be required in the bath to maintain the temperature of the block constant.

**6.3.5 Dry Block Calibrations**—At high temperatures a furnace fitted with a large metal block, can be used in calibration. Insert the test thermometer and the reference thermometer into wells in the block and make comparison calibrations. The method is particularly useful above 300°C and is limited primarily by the temperature uniformity of the block and conduction error of the test thermometer. Make sure that the thermometer wells are both sufficiently deep and close fitting with the thermometers to make the conduction loss error negligible.

**6.4 Reference Thermometers**—Reference thermometers must have a known calibration, a stated uncertainty over the temperature range, and must be suitable for the intended calibration application.

**6.4.1 Standard Platinum Resistance Thermometer (SPRT)**—SPRTs are the most accurate reference thermometers and are used in defining the ITS-90<sup>5</sup> from approximately -259 to 962°C. The SPRT sensing element is made from pure platinum and supported essentially strain-free. Because of the delicate construction, the SPRT is easily damaged by mechanical shock and must be handled carefully to retain its calibration.

**6.4.2 Secondary Reference Thermometers**—Secondary Reference Thermometers are specially manufactured industrial platinum resistance thermometers that are subjected to special heat treating and calibration to establish their measurement uncertainty. These thermometers contain sensing element constructions that are not as easily affected by handling as are SPRT's. However, they also typically have higher measurement uncertainties and narrower usage ranges than SPRT's.

**6.4.3 Reference Thermocouples**—Thermocouples listed in Tables E 230 and Guide E 1751 that have been calibrated on the ITS-90 may also be used as reference thermometers. Noble metal thermocouples are the most commonly used reference thermocouples due to their stability and large usable temperature range.

**6.5 Measurement Instruments**—Several types of instruments can be used. They include analog and digital instruments and those that use resistance bridges, voltage comparison, or current and potential methods.

**6.5.1 AC and DC Bridges and Digital Multimeters**—AC bridges, DC bridges and digital multimeters are becoming increasingly common due to their ease of use and their compatibility with computerized data acquisition systems. These instruments typically provide the user the option of a digital display which can be set to provide readings in ohms, millivolts or temperature. The operating current of these instruments must be low enough that any self-heating of the thermometer is minimized (see Specification E 1137 and Section 12).

**6.5.2 Bridges**—Thermometer resistance can be measured in several bridge configurations. (See Appendix X1 and Appendix X2.) The measurement accuracy can be improved by using bridges that compensate for the connecting wire resistance and spurious thermal emf. Bridges are recommended where high accuracy (0.001 %) and ease of operation are desired.

**6.5.3 Potentiometers**—The laboratory potentiometer can be used to measure the resistance of a four-wire resistance thermometer by comparing the voltage drop across the thermometer element with that across a stable resistor of known value when the same current is flowing through both. The effect of spurious thermal emf should be eliminated by averaging two readings, one taken with normal current and one

<sup>5</sup> Preston-Thomas, H., *Metrologia* 27, 3 (1990); Mangum, B. W., *Journal of Research NIST* 95, 1990, p. 69.

with the current reversed. A typical potentiometric circuit with current reversing switches is described in Appendix X3.

6.6 *Repeatability and Reproducibility (R & R)*—The R & R of the measurements shall be consistent with the specified calibration uncertainties. See Appendix X4 for the results of round robin testing to determine the repeatability and reproducibility of this test.

7. Minimum Immersion Length Test

7.1 *Scope*—Minimum immersion length shall be determined using the procedure described in 7.3. The user must relate this test method to the particular thermometer application, that is, the medium, velocity, turbulence of the fluid, etc., in choosing the design and immersion length of the thermometer. The temperature stability of the test bath and the sensitivity of the measurement instrumentation must be consistent with the specified temperature measurement uncertainty. This test is intended to be a non-destructive test.

7.1.1 This test may not be applicable to thermometers with immersion lengths less than 51 mm (2 in).

7.2 Apparatus:

7.2.1 *Ice-Point Bath*— See 6.3.1.

7.2.2 *Measurement Instrument*—See 6.5.

7.3 Procedure:

7.3.1 Insert the test PRT into the ice-point bath until no further insertion causes significant change in output. This insertion may include the mounting flange, threads, etc. The purpose of this requirement is to maximize heat transfer between the upper part of the thermometer and the bath so that the stem conduction error is negligible.

7.3.2 Use normal operating current (typically 1 mA) if specified. Otherwise, use an operating current which results in no significant self-heating. Record the resistance of the test PRT when equilibrium is reached.

7.3.3 Slowly withdraw the thermometer from the bath in small increments until the resistance increases equivalent to the specified measured uncertainty. Pause long enough after each incremental change in immersion depth to assure thermal equilibrium is reached.

NOTE 5—This depth of immersion in the bath as measured from the tip of the sensor to the surface of the liquid level is the minimum immersion length for the test PRT.

7.4 *Repeatability and Reproducibility (R & R)*—For thermometers with specified measurement uncertainties of 0.01°C to 0.1°C, the minimum immersion length test should be repeatable to ±5 mm and reproducible to ±10 mm. See Appendix X4 for the results of round robin testing to determine the repeatability and reproducibility of the test.

8. Pressure Test

8.1 *Scope*—This test is intended to determine the suitability of the resistance thermometer for operation at elevated pressures. The resistance thermometer should be tested in a vessel that has been completely filled with water.

NOTE 6—**Caution:** Use compressible media only with extreme care because of an inherent explosion hazard. The test apparatus must also be designed to withstand higher test pressures than the test article. This test is intended to be non-destructive, unless the test article fails. If the test

article passes the pressure test, it may then be used in the process application.

8.2 Apparatus:

8.2.1 *Pressure Vessel*— A sketch of a pressure-tight vessel suitable for the test is shown in Fig. 2. The vessel shall be consistent with the pressure requirement.

8.2.2 *Ice-Point Bath*— See 6.3.1.

8.2.3 *Measurement Instruments*—The bridge, potentiometer, or electronic devices used to measure the resistance should be similar to those described in 6.5.

8.2.4 *Pressure Source*— A hand-operated hydraulic pump or other pumping device may be employed along with an indicating pressure gage.

NOTE 7—**Caution:** Observe all the safety precautions applicable for liquid under pressure.

8.2.5 *Insulation-Resistance Apparatus*—Use the apparatus indicated in Section 5 to measure the insulation resistance.

8.3 Procedure:

8.3.1 *Installation*— Mount the resistance thermometer in the pressure vessel (which has previously been filled with

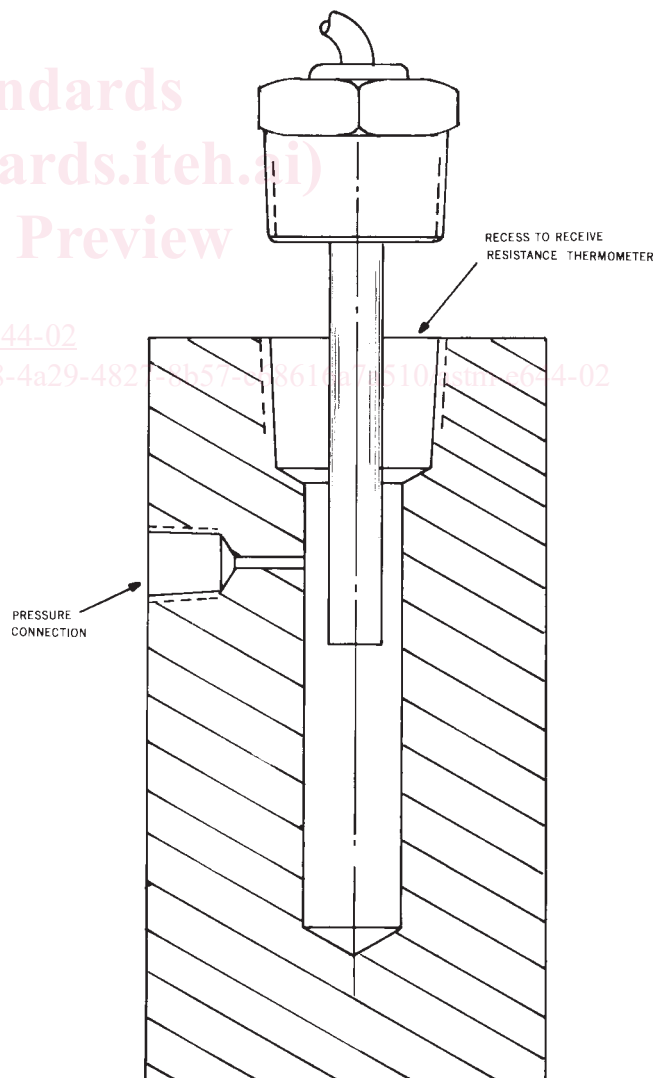

FIG. 2 Pressure Test Vessel

water) such that no leakage will occur. Connect the pressure source to the vessel and attach the thermometer wires to the resistance measuring instrument. Insert the pressure vessel into the ice-point bath and allow the resistance reading to stabilize at temperature.

8.3.2 *Measurements*— With an appropriate excitation current and no hydrostatic pressure applied to the thermometer, allow the output to stabilize. Obtain a resistance measurement at the ice point followed by an insulation-resistance test (see Sections 5 and 6). Pressurize the vessel to within  $\pm 10\%$  of the specified value. After the thermometer readings become steady, repeat the ice point resistance determination and the insulation resistance test with the pressure applied to the thermometer. Reduce the vessel pressure to atmospheric pressure and repeat the ice point and room temperature insulation resistance measurements. Remove the thermometer from the vessel and examine for deformation or any other effects due to the hydrostatic pressurization.

8.3.3 *Qualification*— The differences between the ice point resistance of the thermometer at the test pressure and the average of the two measurements at atmospheric pressure shall constitute the resistance thermometer's pressure stability.

8.4 *Repeatability and Reproducibility (R & R)*—There is a high probability that repetition of the pressure test on a particular thermometer (repeatability) or its subsequent testing by another tester (reproducibility) will provide the same indication of the thermometer's condition. The differences (8.3.3) are significant if greater than the icepoint measurement repeatability (Table X4.1).

## 9. Thermal Response-Time Test

9.1 *Scope*—Thermal response time is that time required for a thermometer to react to a step change of temperature and reach the resistance corresponding to some specified fraction of the total temperature change. This method is applicable to measurements of response time longer than 1 s using strip chart recorders, but has been used successfully to measure shorter response times using digital data acquisition systems. The initial temperature should be ambient to avoid a superimposed transient during the transfer to the second temperature. The measured step response time is the time required, from the initiation of the step change of temperature, for the thermometer assembly to reach a temperature equal to the specified percentage of the step change (10 %, 50 %, 63.2 %, 90 %, 95 %, etc.). Response time of a thermometric process is a function of heat flow into or out of the thermometer and is affected by the bath fluid, boundary layer conditions, velocity, turbulence of the fluid, etc. These conditions must be controlled for reproducible response time measurements. A practical upper limit of fluid velocity in a water test bath is about 1 m/s. At higher flow rates, fluid separation (cavitation) may occur, resulting in significant errors.

9.1.1 The thermometer to be tested is stabilized at an initial temperature and inserted rapidly into a fluid, usually water, flowing at a known velocity at a known final temperature. The resistance of the thermometer is monitored, and the elapsed time is measured from the instant of immersion until the

thermometer has reached a final equilibrium resistance. The time is calculated corresponding to the specified percentage of the difference between the initial temperature and the water temperature. This measured time interval is the thermal response time of the measurement system. The response time with the thermometer in other media may be expected to vary significantly from this value. This test is intended to be non-destructive.

9.2 *Apparatus*—The temperature stability of the ambient conditions, the receiving bath, and the accuracy of the test PRT recording equipment must be consistent with the specified repeatability requirements.

9.2.1 *Fluid Bath*—A typical bath arrangement is shown in Fig. 3. The bath consists of a drum mounted on a vertical shaft driven by an adjustable speed motor. This provides a known and adjustable fluid velocity past the thermometer, which is held in a fixed position in the bath on the end of a pivoted arm. The arm, in its raised position, allows the thermometer to be stabilized at a known initial (usually ambient) temperature before being plunged rapidly into the bath. A switch activated by the arm, signals the start of the timing period at the instant the thermometer enters the fluid. Alternatively, in the case of a water bath, the electrical contact between the metal sheath of the probe and the water can be sensed to initiate the timing period. The water bath temperature can be controlled with infrared lamps directed at the inner walls of the water chamber however other heating methods are possible.

9.2.2 *Measurement Instruments*—Instruments that are compatible with the thermometer and that have an output suitable for a recorder can be used to monitor the thermometer resistance. Current to the thermometer must be limited to a value below the thermometer's self heating threshold to avoid self heating error. See 6.5.

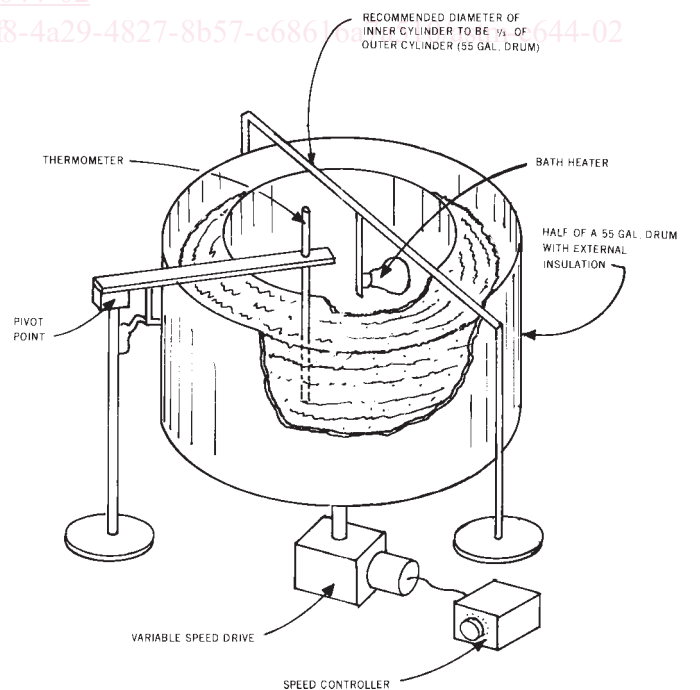

FIG. 3 Typical Bath Arrangement