



Designation: F 1967 – 03

Standard Consumer Safety Specification for Infant Bath Seats¹

This standard is issued under the fixed designation F 1967; the number immediately following the designation indicates the year of original adoption or, in the case of revision, the year of last revision. A number in parentheses indicates the year of last approval. A superscript epsilon (ϵ) indicates an editorial change since the last revision or reapproval.

INTRODUCTION

This consumer safety specification is intended to address certain incidents associated with the use of bath seats, bath rings, and other similar devices.

The U.S. Consumer Product Safety Commission (CPSC) identified drowning incidents which generally involved infants either tipping over, climbing out of, or sliding through the product after being left unattended by their caregiver.

This specification does not address incidents in which bath seats are unreasonably misused, are used in a careless manner that disregards the warnings and instructions that are provided with each product, or those instances where the caregiver leaves the infant unattended in the product.

This consumer safety specification is written within the current state-of-the-art product technology. It is intended that this specification will be updated whenever substantive information becomes available and known to ASTM which necessitates additional requirements or justifies the revision of existing requirements.

1. Scope

1.1 This consumer safety specification establishes performance requirements, test methods, and labeling requirements to promote the safe use of infant bath seats. Products commonly referred as bath rings also are included in the scope of this specification.

1.2 This consumer safety specification is intended to reduce the risk of death and minimize injury to infants resulting from use and reasonably foreseeable abuse of infant bath seats.

1.3 No infant bath seat produced after the approval date of this consumer safety specification shall, either by label or other means, indicate compliance with this specification unless it conforms to all requirements contained herein.

1.4 The following precautionary caveat pertains only to the test methods portion, Section 7, of this consumer safety specification: *This standard does not purport to address all of the safety concerns, if any, associated with its use. It is the responsibility of the user of this standard to establish appropriate safety and health practices and determine the applicability of regulatory limitations prior to use.*

1.5 The test values and dimensions stated in inch–pound units are to be regarded as standard. SI values in parentheses are given for information only.

2. Referenced Documents

2.1 ASTM Standards:

D 3359 Test Methods for Measuring Adhesion by Tape Test²

F 404 Consumer Safety Specification for High Chairs³

F 462 Consumer Safety Specification for Slip-Resistant Bathing Facilities³

F 963 Consumer Safety Specification on Toy Safety³

2.2 Federal Regulations:⁴

16 CFR 1303 Ban of Lead-Containing Paint and Certain Consumer Products Bearing Lead Containing Paint

16 CFR 1500 Federal Hazardous Substances Act Regulations, including sections:

1500.48 Technical Requirements for Determining a Sharp Point in Toys and Other Articles Intended for Use by Children Under 8 Years of Age

1500.49 Technical Requirements for Determining a Sharp Metal or Glass Edge in Toys and Other Articles Intended for Use by Children Under 8 Years of Age

1500.50 Test Methods for Simulating Use and Abuse of Toys and Other Articles Intended for Use by Children

1500.51 Test Methods for Simulating Use and Abuse of Toys and Other Articles Intended for Use by Children 18 Months of Age or Less

¹ This specification is under the jurisdiction of ASTM Committee F15 on Consumer Products and is the direct responsibility of Subcommittee F15.20 on Bath Seats.

Current edition approved March 10, 2003. Published April 2003. Originally approved in 1999. Last previous edition approved in 2001 as F 1967 – 01.

² *Annual Book of ASTM Standards*, Vol. 06.01.

³ *Annual Book of ASTM Standards*, Vol. 15.07.

⁴ *Code of Federal Regulations*, available from U.S. Government Printing Office, Washington, DC 20402.

16 CFR 1501 Method for Identifying Toys and Other Articles Intended for Use by Children Under 3 Years of Age Which Present Choking, Aspiration, or Ingestion Hazards Because of Small Parts

3. Terminology

3.1 Definitions of Terms Specific to This Standard:

3.1.1 *bath seat, n*—a bath seat, bath ring, or other similar product intended to be placed into a bath tub, sink, or similar bathing enclosure to provide support to a seated infant during bathing by an adult caregiver. The product is intended for use only with an infant who is capable of sitting upright unassisted.

3.1.2 *locking or latching mechanism, n*—method of preventing a bath seat from folding or collapsing during use.

3.1.3 *manufacturer's recommended use position(s), n*—any position that is presented as a normal, allowable, or acceptable configuration for the use of the product by the manufacturer in any descriptive or instructional literature. This specifically excludes positions which the manufacturer shows in a like manner in its literature to be unacceptable, unsafe or not recommended.

3.1.4 *nonpaper label, n*—any label material, such as plastic or metal, that either will not tear without the aid of tools or tears leaving a sharply defined edge or labels made of fabric.

3.1.5 *occupant, n*—that individual who is in an infant bath seat in one of the manufacturer's recommended use positions.

3.1.6 *paper label, n*—any label material that tears without the aid of tools and leaves a fibrous edge.

3.1.7 *principal display panel, n*—that part of the product's package that is most likely to be displayed, presented, shown or examined under normal or customary conditions of display for retail sale.

3.1.8 *stability, n*—the ability of a bath seat to remain upright in all of the manufacturer's recommended use positions.

3.1.9 *static load, n*—a vertically downward load applied by weights or other means.

4. Calibration and Standardization

4.1 Unless otherwise noted, the bath seat shall be completely assembled in accordance with the manufacturer's instructions.

4.2 The product to be tested shall be in a room with an ambient temperature of $73 \pm 9^\circ\text{F}$ ($23 \pm 5^\circ\text{C}$) for at least 1 h prior to testing. Testing then shall be conducted within this temperature range.

4.3 All testing required by this specification shall be conducted on the same unit.

5. General Requirements

5.1 There shall be no hazardous sharp points or edges as defined in 16 CFR 1500.48 and 16 CFR 1500.49 before or after the product has been tested to this consumer safety specification.

5.2 There shall be no small parts as defined in 16 CFR 1501 before testing or liberated as a result of testing to this specification.

5.3 All decorated surfaces of the product shall comply with the requirements of 16 CFR 1303.

5.4 Latching and Locking Mechanism:

5.4.1 Any unit that folds shall have a latching or locking device or other provision in the design that will prevent the unit from unintentionally folding when properly placed in the manufacturer's recommended use position(s).

5.4.2 During and upon completion of the test in accordance with 7.1.1, the unit shall remain in the manufacturer's recommended use position, and the latching or locking mechanism shall remain engaged and operative after testing.

5.4.3 For all single action locking/latching mechanisms, the mechanism shall not release with a minimum force of 10 lbf (45 N) when tested in accordance with 7.1.2.

5.4.4 For all double action locking/latching mechanisms, there is no force requirement when tested in accordance with 7.1.2.

5.4.5 The latching or locking mechanism shall also comply with all requirements in 7.1 after cycling has been conducted in accordance with 7.1.3.

5.5 *Scissoring, Shearing, and Pinching*—The unit, when in the manufacturer's use position(s), shall be designed and constructed to prevent injury to the occupant from any scissoring, shearing, or pinching when members or components rotate about a common axis or fastening point, slide, pivot, fold or otherwise move relative to one another. Scissoring, shearing, or pinching exists when the edges of the rigid parts admit a probe greater than 0.210 in. (5.3 mm) and less than 0.375 in. (9.5 mm) at any accessible point throughout the range of motion of such parts.

5.6 *Openings*—Any shaped holes, slots, or cracks that exist in the product in any of its manufacturer's recommended use positions and that are accessible to the toes or fingers of the occupant through or recessed, or both, into the surface of any rigid material that admits a 0.210-in. (5.3-mm) diameter rod, also shall admit a 0.375-in. (9.5-mm) diameter rod. Openings that have a minor dimension between 0.210 in. (5.3 mm) and 0.375 in. (9.5 mm) shall be permissible, providing the depth is no greater than the minor dimension of the opening.

5.7 *Removal of Components*—If a child can grasp any components between the thumb and forefinger, or teeth, such as caps, sleeves, or plugs used for protection from sharp edges, points, or entrapment of fingers or toes, or if there is at least a 0.040-in. (1.00-mm) gap between the component and its adjacent parent component when the product is in its manufacturer's recommended use position(s), such component shall not be removed when tested in accordance with 7.2.

5.8 *Requirements for Toys*—Toy accessories attached to, removable from, or sold with bath seats, as well as their means of attachment, must meet applicable requirements of Consumer Safety Specification F 963.

5.9 Labeling:

5.9.1 Warning labels, whether paper or nonpaper, shall be permanent when tested in accordance with 7.3.

5.9.2 Warning statements applied directly onto the surface of the product by hot stamping, heat transfer, printing, wood burning, etc. shall be permanent when tested in accordance with 7.3.

5.9.3 Nonpaper labels shall not liberate small parts when tested in accordance with 7.3.5.

6. Performance Requirements

6.1 *Stability*—For bath seats whose primary method of stability is contact with the bathing surface and which provide support for an occupant’s back and support for the sides and/or front of the occupant, the product shall not allow for any parts of the product to become separated from it, shall not sustain permanent damage and shall not tip over after being tested in accordance with 7.4.

6.2 *Restraint System:*

6.2.1 Bath seats, when in the manufacturer’s recommended use position(s), which provide support for an occupant’s back and support for the sides or front, or both, of the occupant’s torso must provide a passive crotch restraint and comply with 6.2.1.1. The bath seat shall not include any additional restraint system which requires action on the part of the caregiver to secure the restraint.

6.2.1.1 A passive crotch restraint shall be assembled as part of the bath seat before shipment from the manufacturer or shall be designed such that the bath seat cannot be used without the passive crotch restraint in place. The passive crotch restraint shall be permanently attached to the bath seat.

6.2.2 Bath seats, when in the manufacturer’s recommended use position(s), which provide support for an occupant’s back only and do not provide support for the sides and/or front of the occupant’s torso must comply with 6.2.2.1.

6.2.2.1 These bath seats are not required to have a restraint; however, if one is provided, it must be either a passive crotch restraint which complies with 6.2.1 or both a waist and crotch restraint in which the crotch restraint shall be designed such that its use is mandatory when the restraint system is in use.

6.3 *Static Load*—The product shall not break, become permanently deformed or damaged, or fail to comply with any of the other requirements of this specification when tested in accordance with 7.5.

6.4 *Specific Requirements for Suction Cups*—Bath seats that utilize individual suction cups as a method of attachment to the bathing surface shall comply with the following requirements:

6.4.1 Each suction cup shall remain attached to the base of the bath seat and shall not become damaged or broken after testing in accordance with 7.6.1.

6.4.2 The bath seat shall remain attached to the test surface(s) and shall not become damaged or broken after testing in accordance with 7.6.2.

6.5 *Leg Openings*

6.5.1 All openings on the sides of the product through which a seated occupant can slide or otherwise insert any extremity shall not permit the passage of the Bath Seat Torso Test Probe when tested in accordance with 7.7.1.

6.5.2 When these same openings are tested in accordance with 7.7.2, the 1.0 in. (25 mm) perimeter of the Bath Seat Shoulder Test Probe at the shoulder breadth end shall not be permitted to contact the seating surface of the product.

7. Test Methods

7.1 *Latching and Locking Mechanism:*

7.1.1 *Resistance to Folding:*

7.1.1.1 Erect the bath seat in one of the manufacturer’s recommended use position(s) on the smooth surface fixture. Secure the product so that the normal folding motion is not impeded.

7.1.1.2 Apply a force of 45 lbf (200 N) in the direction normally associated with folding the bath seat.

7.1.1.3 Repeat this procedure five times within a 2-min period.

7.1.1.4 Submerge the product in enough clear water to fully cover the latching/locking mechanism. Water shall be at an initial temperature of 100 to 105°F (37.8 to 40.6°C).

7.1.1.5 Repeat the testing prescribed above in 7.1.1.1-7.1.1.3.

7.1.1.6 Repeat the testing in both the dry and the submerged conditions for each additional manufacturer’s recommended use position.

7.1.2 *Release Mechanism Activation:*

7.1.2.1 *Products With Single Action Release Mechanism*—With the product in each manufacturer’s recommended use position, gradually apply a 10 lbf (45 N) force to the locking or latching mechanism in the direction tending to release it.

7.1.2.2 *Products With Double Action Release Mechanism*—Each double action locking/latching mechanism shall require two distinct and separate actions for release of the mechanism.

7.1.3 *Latching or Locking Mechanism Durability*—The latching or locking mechanism shall be cycled through its normal operation a total of 2000 cycles. Each cycle shall consist of opening and closing the mechanism and erecting/folding the bath seat. Cycling should be conducted over an appropriate time period so that any fatigue or wear effects of rapid repetitions will not inadvertently affect the results.

7.2 *Protective Components:*

7.2.1 If the torque and tension tests are to be conducted on the product, first completely submerge the testable components for 20 min in clear water that is at an initial temperature of 100 to 105°F (37.8 to 40.6°C). Conduct the torque and tension tests within 10 min after removal from the water.

7.2.2 *Torque Test for Graspable Components:*

7.2.2.1 Using any convenient method to hold the parent component in place, grasp the component to be tested and apply a torque evenly over a period of 5 s in a clockwise direction until either a rotation of 180° is attained or a torque value of 4 lbf-in. (0.4 N-m) has been reached.

7.2.2.2 Maintain the torque value or the 180° rotation for an additional 10 s and then allow the component to return to its original position.

7.2.2.3 Repeat this test using a torque in the counter-clockwise direction.

7.2.3 *Tension Test for Graspable Components*—The same component which has undergone the torque test also shall undergo the following tension test immediately following the torque test:

7.2.3.1 Hold the parent component in place using a suitable device and then grasp the component to be tested and apply a tension force of 15 lbf (67 N) evenly over a period of 5 s in the direction normally associated with the removal of the component. The device used to grasp the component should not

compress or expand the component being tested so that it hinders any possible removal.

7.2.3.2 Maintain this force for an additional 10 s.

7.3 *Permanence of Labels and Warnings*—To determine the permanence of a label or printing applied to the surface of the product, first completely submerge the label or printed area for 20 min in clear water that is at an initial temperature of 100 to 105°F (37.8 to 40.6°C).

7.3.1 A paper label (excluding labels attached by a seam) shall be considered permanent if, during an attempt to remove it without the aid of tools or solvents, it cannot be removed, it tears into pieces upon removal or such action damages the surface to which it is attached.

7.3.2 A nonpaper label (excluding labels attached by a seam) shall be considered permanent if, during an attempt to remove it without the aid of tools or solvents, it cannot be removed or such action damages the surface to which it is attached.

7.3.3 A warning label attached by a seam shall be considered permanent if it does not detach when subjected to a 15 lbf (67 N) pull force applied in any direction using a 3/4-in. diameter clamp surface.

7.3.4 Adhesion test for warnings applied directly onto the surface of the product.

7.3.4.1 Apply the tape test defined in Test Method B, Cross-Cut Tape Test of D 3359, eliminating parallel cuts.

7.3.4.2 Perform this test once in each different location where warnings are applied.

7.3.4.3 The warning statements will be considered permanent if the printing in the area tested is still legible and attached after being subjected to this test.

7.3.5 A nonpaper label, during an attempt to remove it without the aid of tools or solvents, shall not be removed or shall not fit entirely within the small parts cylinder defined in 16 CFR 1501 if it can be removed.

7.4 *Stability*:

7.4.1 Install the product according to the manufacturer's instructions onto the test surface(s) specified in 7.4.3. If the manufacturer's instructions state that the product should be used only on a smooth surface, then the test shall be conducted using only the smooth surface. If the manufacturer's instructions allow for use of the product on a slip-resistant surface, then the test must be conducted using both the smooth surface and the slip resistant surface.

7.4.1.1 The tests for stability must be conducted after the test surface has been flooded with water that is at an initial temperature of 100 to 105°F (37.8 to 40.6°C) to a depth of 2 in. (51 mm) above the occupant seating surface, and the bath seat has been placed in the manufacturer's recommended use position on the surface.

7.4.2 *Test Protocol*:

7.4.2.1 Attach a 1 by 1/4-in. (25 by 6-mm) rigid aluminum flat bar to the inside edge of any vertical member of the bath seat. The length of the flat bar must be such that it extends beyond the uppermost edge or surface of the bath seat at least as far as the maximum distance *D* (calculated below).

7.4.2.2 Calculate the distance *D* for a tipover force to be applied to the aluminum bar using the following formula:

$$D = (20.4 \text{ in.} - H)/2 \quad [(518 \text{ mm} - H)/2] \quad (1)$$

where:

H = the height of the uppermost edge of the vertical member above the seating surface or the height of the uppermost horizontal surface, if one is present at that position, above the seating surface, whichever is greater.

7.4.2.3 Apply a force of 17.0 lbf (76.5 N) to the aluminum bar at this distance *D* above the height *H*. Apply the force in a horizontal plane and outward from the center of the bath seat over a period of 5 s (see Fig. 1). Maintain this force for an additional 10 s. If the bath seat begins to release from the test fixture, continue to maintain this force and its orientation

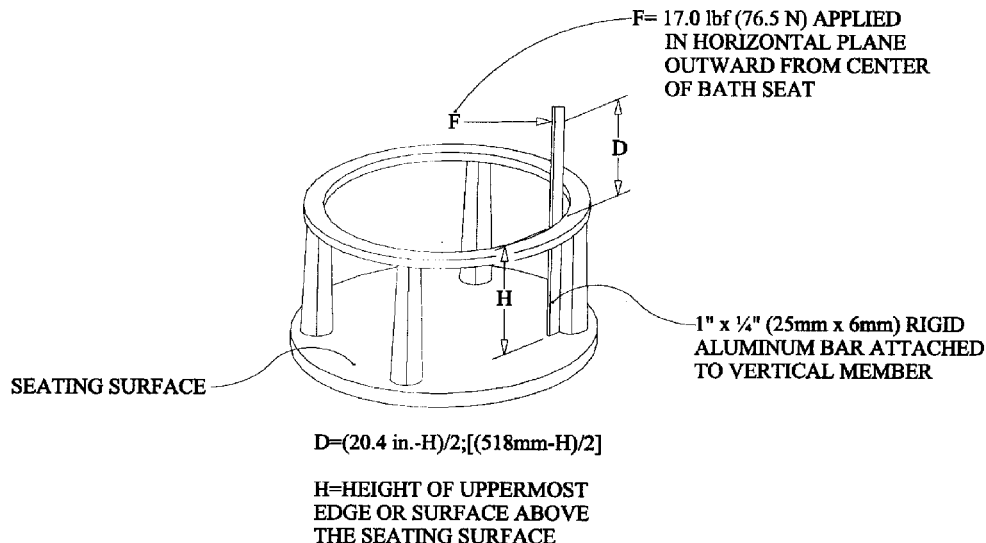

FIG. 1 Diagram of Force Application

relative to the aluminum bar until the bath seat tips over or the 10 s time limit is attained.

NOTE 1—If necessary, to prevent the bath seat from sliding horizontally on the test surface during this test protocol, the bottom edge of the bath seat may be blocked or wedged to prevent such sliding; however, such blocking should in no way interfere or influence the results of this test protocol.

7.4.2.4 At the position of each vertical member of the bath seat, repeat this test protocol, including the re-calculation of the distance *D*.

7.4.2.5 Repeat this test protocol with the product in each of the manufacturer's recommended use position(s).

7.4.3 Test Surfaces:

7.4.3.1 Prior to using either test surface, the test surface should be cleaned thoroughly using an alcohol or other solvent based cleaner to remove all foreign material.

7.4.3.2 *Smooth Surface*—A smooth, flat, rigid piece of plexiglass large enough to accommodate the positioning of the bath seat in the manufacturer's recommended use position(s).

7.4.3.3 *Slip Resistant Surface*—Any surface which meets the definition established in Consumer Safety Specification F 462 simulates the bathtub surfaces described therein, and is large enough to accommodate the positioning of the bath seat in the manufacturer's recommended use position(s).

7.5 Static Load Test:

7.5.1 Install the product according to the manufacturer's instructions onto the smooth surface test fixture.

7.5.2 Conduct the static load test in clear water that is at an initial temperature of 100 to 105°F (37.8–40.6°C) and that is at a depth of 2 in. (51 mm) above the occupant seating surface.

7.5.3 Place a weight of 30 lb (13.6 kg) on the center of the seat and distribute it upon a 6 by 6-in. (150 by 150-mm) ³/₄-in. (19-mm) thick block made of high density polyethylene (HDPE).

7.5.4 Remove the weight after a time period of 20 min and observe the product for any breakage, deformation, damage, or failure to meet any other requirements of this standard.

7.6 Suction Cup Tests:

7.6.1 Suction Cup Attachment to Bath Seat:

7.6.1.1 Install the product according to the manufacturer's instructions onto the smooth test surface specified in 7.4.3.2. Flood the surface with clear water that is at an initial temperature of 100 to 105°F (37.8–40.6°C) and that is at a depth of 2 in. (51 mm) above the occupant seating surface. Allow the product to soak for a minimum of 20 min.

7.6.1.2 Remove the product according to the manufacturer's instructions and immediately apply to each suction cup a tensile force of 25 lbf (111 N). Apply this force within 5 s and in the direction most likely to cause failure. Hold the force for an additional 10 s.

7.6.2 Suction Cup Attachment to Bathing Surface:

7.6.2.1 Install the product according to the manufacturer's instructions onto the test surface(s) specified in 7.4.3. If the manufacturer's instructions state that the product should be used only on a smooth surface, then the test shall be conducted using only the smooth surface. If the manufacturer's instructions allow for use of the product on a slip-resistant surface, then the test must be conducted using both the smooth surface

and the slip resistant surface. The tests for attachment must be conducted after the test surface has been flooded with water that is at an initial temperature of 100 to 105°F (37.8 to 40.6°C) to a depth of 2 in. (51 mm) above the occupant seating surface, and the bath seat has been placed in the manufacturer's recommended use position(s) on the surface. Allow the product to soak for a minimum of 20 min.

7.6.2.2 Within 5 s, apply a vertical tensile force of 25 lbf (111 N) at the center of the product. Hold the force for an additional 10 s.

7.6.2.3 Remove and install the bath seat into the manufacturer's recommended use position(s) a total of 2000 cycles using the manufacturer's recommended method(s).

7.6.2.4 Repeat the testing specified in 7.6.2.2.

7.7 Leg Openings

7.7.1 With the bath seat in each of the manufacturer's recommended use position(s), insert the tapered end of the Bath Seat Torso Probe (see Fig. 2) in the most adverse orientation into each opening. The probe should be inserted from the direction of the occupant seating surface. Gradually apply a force of 15 lbf (67 N) in the direction of the major axis of the probe within a period of 5 s. Maintain this force for an additional 10 s (see Fig. 3).

7.7.2 With the bath seat in each of the manufacturer's recommended use position(s), insert the tapered end of the Bath Seat Shoulder Probe (see Fig. 4) in the most adverse orientation into each opening. The probe should be inserted from the direction of the occupant seating surface. Gradually apply a force of 15 lbf (67 N) in the direction of the major axis of the probe within a period of 5 s. Maintain this force for 10 s (see Fig. 5). Release and apply a force of 10 lbf (44 N) to the top 1.0 in. (25 mm) perimeter of the probe in a direction vertically downward toward the seating surface over a period of 5 s. Maintain this force for an additional 10 s (see Fig. 6).

8. Marking and Labelling

8.1 Each unit of product and its packaging shall be labeled with the safety alert symbol (exclamation mark within an equilateral triangle), the signal word WARNING in all capital letters, as well as the following two sentences:

Prevent drowning. ALWAYS keep baby within arm's reach.

8.1.1 The signal word and all other capital letters shall be in sans serif type face with letters not less than 0.2 in. (5 mm) in height, with all remainder of the text not less than 0.1 in. (2.5 mm) in height. Specified warning(s) on both the product and the package shall be distinctively separated from any other wording or designs and shall appear in the English language at a minimum. They shall also be in a contrasting color to the background on which they are located.

8.2 The warning specified in 8.1 shall be located on the product so that it is visible to the adult caregiver when the product is in the manufacturer's recommended use position(s) and the occupant is in the product.

8.3 Specified warning(s) on the package shall be on the principal display panel.

8.4 Slip-resistant Warning

8.4.1 Products not recommended by the manufacturer for use on slip-resistant surfaces, as defined in Specification F 462, or as otherwise determined by the manufacturer, shall also

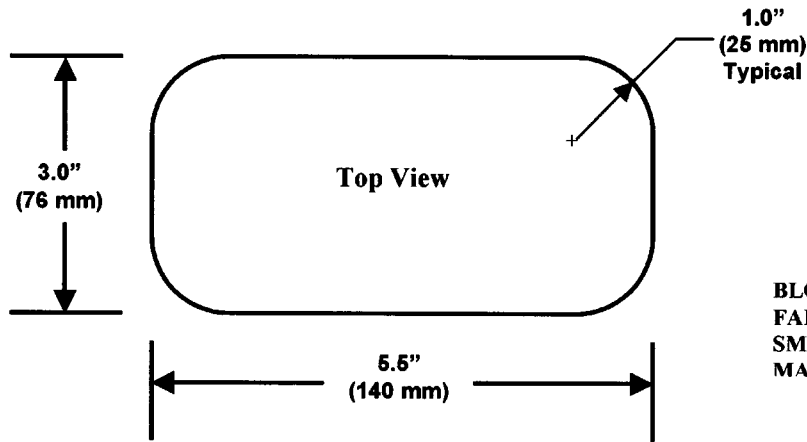

BLOCK SHALL BE FABRICATED FROM A SMOOTH RIGID MATERIAL.

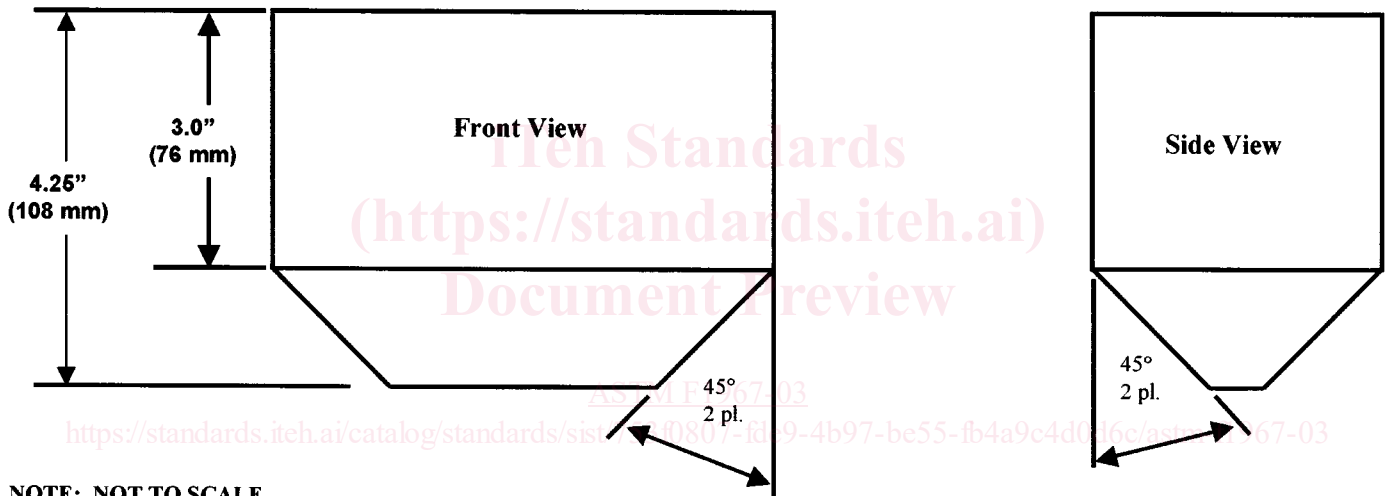

NOTE: NOT TO SCALE

FIG. 2 Bath Seat Torso Probe

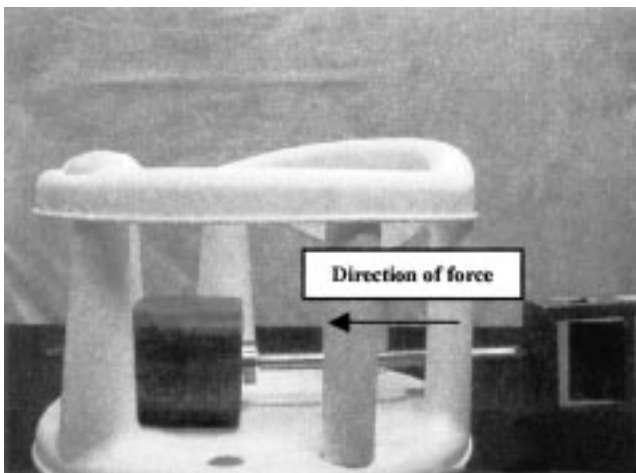

FIG. 3 Bath Seat Torso Probe Force

include a warning to this effect on both the product and the principal display panel of the package. This warning shall use the safety alert symbol and the signal word WARNING, and shall address the following: Prevent drowning. Use ONLY on smooth surfaces. Suction cups will not stick to slip-resistant surfaces.

8.4.2 If there are other types of surfaces that the manufacturer does not recommend the product to be used on, then additional warnings shall be given regarding such surfaces.

8.4.3 The warnings in 8.4.1 and 8.4.2 shall comply with the requirements of 8.1.1 for letter height, language, color, and type. These warnings shall be located on the product so they are visible to the caregiver when the product is in the manufacturer's recommended use position(s), but not necessarily when the occupant is in the product.

8.4.4 If the warning in 8.4.1 or 8.4.2, or both, is placed directly under or adjacent to the warning required by 8.1, then