



Designation: D 246 – 95<sup>ε1</sup>

American Association State  
Highway Transportation Officials Standard  
AASHTO No. T 62

## Standard Test Method for Distillation of Creosote and Creosote-Coal Tar Solutions<sup>1</sup>

This standard is issued under the fixed designation D 246; the number immediately following the designation indicates the year of original adoption or, in the case of revision, the year of last revision. A number in parentheses indicates the year of last reappraisal. A superscript epsilon ( $\epsilon$ ) indicates an editorial change since the last revision or reappraisal.

<sup>ε1</sup> NOTE—An editorial correction was made in 5.8 in March 1998.

### 1. Scope

1.1 This test method covers a procedure for the distillation of creosote and creosote-coal tar solution. Test Methods D 38 covers the sampling of wood preservatives prior to testing.

1.2 *This standard does not purport to address all of the safety concerns, if any, associated with its use. It is the responsibility of the user of this standard to establish appropriate safety and health practices and determine the applicability of regulatory limitations prior to use.*

### 2. Referenced Documents

#### 2.1 ASTM Standards:

D 38 Test Methods for Sampling Wood Preservatives Prior to Testing<sup>2</sup>

D 370 Test Method for Dehydration of Oil-Type Preservatives<sup>2</sup>

D 390 Specification for Coal-Tar Creosote for the Preservative Treatment of Piles, Poles, and Timbers for Marine, Land, and Fresh Water Use<sup>2</sup>

D 391 Specification for Creosote-Coal Tar Solution<sup>2</sup>

E 1 Specification for ASTM Thermometers<sup>3</sup>

E 1404 Specification for Laboratory Glass Conical Flasks<sup>4</sup>

E 1405 Specification for Laboratory Glass Distillation Flasks<sup>4</sup>

### 3. Summary of Test Method

3.1 A 100-g sample is distilled at a controlled rate in a 300-mL flask. The weights of distillate fractions at a series of specified temperatures and of residue at the maximum specified temperature are determined. The residue and distillates may be tested by appropriate procedures.

<sup>1</sup> This test method is under the jurisdiction of ASTM Committee D-7 on Wood and is the direct responsibility of Subcommittee D07.06 on Treatments for Wood Products.

Current edition approved Sept. 10, 1995. Published November 1995. Originally published as D 246 – 26 T. Last previous edition D 246 – 95.

This test method is identical in substance with the Standard Method of Distillation which is part of the American Wood-Preservers' Association Standard Methods for Analysis of Creosote and Oil-Type Preservatives (A1). Acknowledgment is made to the American Wood Preservers' Association for its development of the subject matter covered in this test method.

<sup>2</sup> *Annual Book of ASTM Standards*, Vol 04.10.

<sup>3</sup> *Annual Book of ASTM Standards*, Vol 14.03.

<sup>4</sup> *Annual Book of ASTM Standards*, Vol 14.02.

### 4. Significance and Use

4.1 Creosote quality is defined by the boiling ranges of its distillation fractions. The boiling limits of the fractions as determined by this test method must conform to the limits established by Specifications D 390 and D 391 to qualify the creosote as an acceptable preservative for its intended application.

### 5. Apparatus

5.1 *Flask*—Distillation flask, 300 mL, specified as Type II, Class 2 in Specification E 1405.

5.2 *Condenser Tube*—A tapered glass condenser, as shown in Fig. 1 and Fig. 2, conforming to the following dimensions:

Diameter of small end, outside	12.5 ± 1.5 mm
Diameter of large end, outside	28.5 ± 3.0 mm
Length	360 ± 4 mm
Length of tapered part	100 ± 5 mm

5.3 *Source of Heat*—A source of heat consisting of a bunsen or Meker type gas burner or an electric heater. The electric heater<sup>5</sup> shall have an output variable to 600 or to 750 W and removable upper and lower refractories as illustrated in Fig. 3. The temperature of the heater shall be controlled by a variable transformer or rheostat suitable for the voltage used, and shall be fitted with a clamp for mounting on a vertical support rod.

5.4 *Flask Shield for Flame Distillation*—A stainless steel shield, fitted with mica windows and lined with 1/8-in. heat-resistant ceramic board, with two-part cover made from 1/4-in. "Transite" board of the forms and dimensions shown in Fig. 4.

5.5 *Flask Shield for Electric-Heater Distillation*—A stainless steel shield fitted with mica windows and cover of the same construction and dimensions as those for flame distillation (5.4), except for the height of the shield. See Fig. 5.

5.6 *Gauze*—Two sheets of 16-mesh wire gauze made with 0.51-mm (0.02-in.) diameter Nichrome wire and 125 to 152 mm in diameter or square.

5.7 *Burner Chimney for Flame Distillation*—A cylindrical metal chimney approximately 100 mm high, 95 to 105 mm in diameter, and having a peephole 25 mm in diameter centered about 32 mm below the ring support, used to protect the flame

<sup>5</sup> The "Precision" Ful-Kontrol 750-W heater with built-in variable transformer control has been found satisfactory. This heater is available for 115 V, 50/60 Hz only.

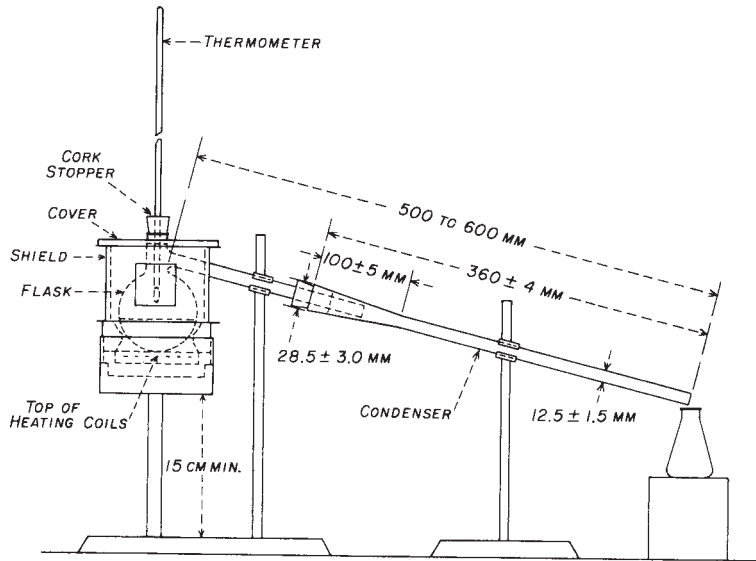

FIG. 1 Apparatus Assembly for Flame Distillation

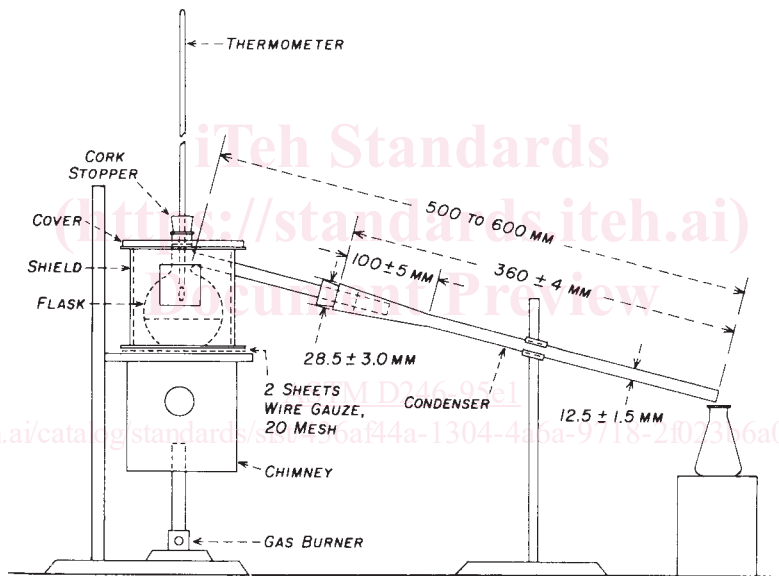

FIG. 2 Apparatus Assembly for Electric-Heater Distillation

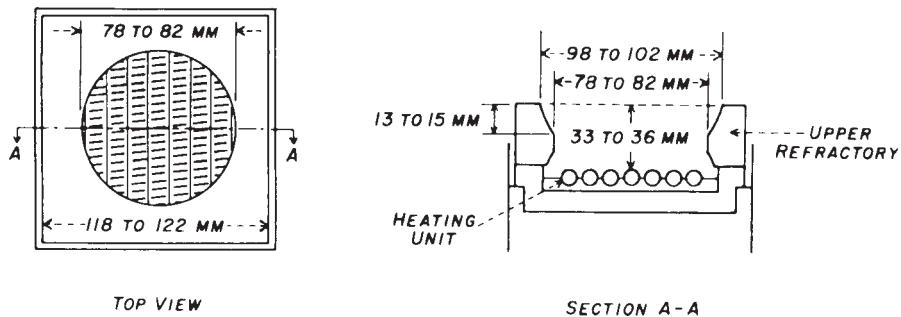

FIG. 3 Upper Part of Electric Heater

from air currents. The top of the shield should be flanged to permit its being suspended from the ring support.

5.8 *Receivers*—Standard 125-mL conical flasks, specified as Type I, Class 1 in Specification E 1404.