



SLOVENSKI STANDARD

SIST EN 74-2:2008

01-december-2008

Gdc^_Yžj YnbYWbĥ] bY'gdc^_Y]b'dcXbcÿbY'd'cý Y'nUXY'cj bY]b'bcg]bY'cXfY!'&"
XY.'GdYWU]bY'gdc^_Y!'NUA ĥj Y]b'dfYg_i gb]dcglcd_]

Couplers, spigot pins and baseplates for use in falsework and scaffolds - Part 2: Special couplers - Requirements and test procedures

Kupplungen, Zentrierbolzen und Fußplatten für Arbeitsgerüste und Traggerüste -
Spezialkupplungen - Teil 2: Anforderungen und Prüfverfahren

Raccords, goujons d'assemblage et semelles pour étaielements et échafaudages - Partie
2: Raccords spéciaux - Exigences et modes opératoires d'essai

<https://standards.iteh.ai/catalog/standards/sist/1bcf9492-6d6e-466f-beb4-16ec258d46a6/sist-en-74-2-2008>

Ta slovenski standard je istoveten z: **EN 74-2:2008**

ICS:

91.220

Gradbena oprema

Construction equipment

SIST EN 74-2:2008

en

iTeh STANDARD PREVIEW
(standards.iteh.ai)

SIST EN 74-2:2008

<https://standards.iteh.ai/catalog/standards/sist/1bcf9492-6d6e-466f-beb4-16ec258d46a6/sist-en-74-2-2008>

EUROPEAN STANDARD
NORME EUROPÉENNE
EUROPÄISCHE NORM

EN 74-2

September 2008

ICS 91.220

English Version

Couplers, spigot pins and baseplates for use in falsework and scaffolds - Part 2: Special couplers - Requirements and test procedures

Raccords, goujons d'assemblage et semelles pour
étaisements et échafaudages - Partie 2: Raccords spéciaux
- Exigences et modes opératoires d'essai

Kupplungen, Zentrierbolzen und Fußplatten für
Arbeitsgerüste und Traggerüste - Spezialkupplungen - Teil
2: Anforderungen und Prüfverfahren

This European Standard was approved by CEN on 9 August 2008.

CEN members are bound to comply with the CEN/GENELEC Internal Regulations which stipulate the conditions for giving this European Standard the status of a national standard without any alteration. Up-to-date lists and bibliographical references concerning such national standards may be obtained on application to the CEN Management Centre or to any CEN member.

This European Standard exists in three official versions (English, French, German). A version in any other language made by translation under the responsibility of a CEN member into its own language and notified to the CEN Management Centre has the same status as the official versions.

CEN members are the national standards bodies of Austria, Belgium, Bulgaria, Cyprus, Czech Republic, Denmark, Estonia, Finland, France, Germany, Greece, Hungary, Iceland, Ireland, Italy, Latvia, Lithuania, Luxembourg, Malta, Netherlands, Norway, Poland, Portugal, Romania, Slovakia, Slovenia, Spain, Sweden, Switzerland and United Kingdom.

<https://standards.iteh.ai/catalog/standards/sist/16cd492-6d6e-466f-beb4-16ec258d46a6/sist-en-74-2-2008>



EUROPEAN COMMITTEE FOR STANDARDIZATION
COMITÉ EUROPÉEN DE NORMALISATION
EUROPÄISCHES KOMITEE FÜR NORMUNG

Management Centre: rue de Stassart, 36 B-1050 Brussels

Contents

Page

Foreword.....	3
Introduction	4
1 Scope	5
2 Normative references	5
3 Terms and definitions	6
4 Symbols	8
5 Types and classification of special couplers	9
6 Transmissible internal forces, moments and related stiffnesses	10
6.1 General.....	10
6.2 Half coupler	11
6.3 Sleeve coupler with shear studs (SS).....	12
6.4 Reduction coupler	12
7 Reference tubes/bar for coupler tests	14
8 General requirements.....	15
8.1 Materials	15
8.2 Design	15
8.3 Manufacturer's drawings	17
8.4 Production control.....	17
9 Tests methods and evaluation of results.....	17
9.1 General.....	17
9.2 Half Couplers.....	18
9.3 Sleeve couplers with shear studs (SS).....	27
9.4 Reduction couplers	30
10 Designation	30
11 Marking	31
12 Test report	31
13 Assessment.....	31
14 Product Manual.....	31
Annex A (informative) Ongoing production control	33
Annex B (informative) Information about the design of temporary works structures	35
B.1 General.....	35
B.2 Structural design	35
Bibliography	41

ITeH STANDARD PREVIEW
(standards.iteh.ai)

SIST EN 74-2:2008

<https://standards.iteh.ai/catalog/standards/sist/16cd492-6d0c-406f-bcb4-16cc258d46a0/sist-en-74-2-2008>

16cc258d46a0/sist-en-74-2-2008

Foreword

This document (EN 74-2:2008) has been prepared by Technical Committee CEN/TC 53 “Temporary works equipment”, the secretariat of which is held by DIN.

This European Standard shall be given the status of a national standard, either by publication of an identical text or by endorsement, at the latest by March 2009, and conflicting national standards shall be withdrawn at the latest by March 2009.

Attention is drawn to the possibility that some of the elements of this document may be the subject of patent rights. CEN [and/or CENELEC] shall not be held responsible for identifying any or all such patent rights.

The couplers specified in this European Standard are intended for use in temporary works for example scaffolds erected in accordance with EN 12811-1 and falsework erected in accordance with EN 12812.

In accordance with the CEN/CENELEC Internal Regulations, the national standards organizations of the following countries are bound to implement this European Standard: Austria, Belgium, Bulgaria, Cyprus, Czech Republic, Denmark, Estonia, Finland, France, Germany, Greece, Hungary, Iceland, Ireland, Italy, Latvia, Lithuania, Luxembourg, Malta, Netherlands, Norway, Poland, Portugal, Romania, Slovakia, Slovenia, Spain, Sweden, Switzerland and the United Kingdom.

iTeh STANDARD PREVIEW
(standards.iteh.ai)

[SIST EN 74-2:2008](https://standards.iteh.ai/catalog/standards/sist/1bcf9492-6d6e-466f-beb4-16ec258d46a6/sist-en-74-2-2008)

<https://standards.iteh.ai/catalog/standards/sist/1bcf9492-6d6e-466f-beb4-16ec258d46a6/sist-en-74-2-2008>

EN 74-2:2008 (E)**Introduction**

This is the second of three parts of a standard for couplers.

EN 74-1 deals with common types of friction couplers.

EN 74-2 deals with other less common types of friction couplers and other couplers.

EN 74-3 deals with non-adjustable base plates and loose spigot pins.

EN 74-2 is not intended to prevent the development of other types of couplers; for example couplers may be manufactured in aluminium or other materials or be designed for use with steel or aluminium tubes with outside diameters different from those specified in this standard.

Whilst such couplers cannot conform to this standard, it is recommended that the principles of this standard are considered in their design and assessment.

NOTE In the text of this standard, the term "loose spigot" is used instead of the "spigot pin" in the title.

iTeh STANDARD PREVIEW
(standards.iteh.ai)

SIST EN 74-2:2008

<https://standards.iteh.ai/catalog/standards/sist/1bcf9492-6d6e-466f-beb4-16ec258d46a6/sist-en-74-2-2008>

1 Scope

EN 74-2 specifies:

- materials;
- design requirements;
- specified values for resistances and stiffnesses which a coupler has to achieve under test;
- test procedures and assessment;

for the following special couplers:

- screw or wedge half couplers, sleeve couplers with shear studs, right angle reduction couplers and swivel reduction couplers.

It gives recommendations for on-going production control.

These couplers are for use principally in temporary works. Each coupler is able to be fixed to at least one side to one 48,3 mm diameter steel or aluminium tube. For the other side of reduction couplers, this standard specifies requirements for the diameter and wall thickness of tubes.

For testing, screw couplers are tightened with a torque of 50 Nm and wedge couplers are tightened with a 500 g hammer until the jarring blow.

Other special half couplers such as half couplers attached by riveting, used mainly for members of prefabricated scaffolds, are outside the scope of this European Standard.

NOTE Information on design using special couplers is given in Annex B.

2 Normative references

The following referenced documents are indispensable for the application of this document. For dated references, only the edition cited applies. For undated references, the latest edition of the referenced document (including any amendments) applies.

EN 74-1:2005, *Couplers, spigot pins and baseplates for use in falsework and scaffolds — Part 1: Couplers for tubes — Requirements and test procedures*

EN 1090-2:2008, *Execution of steel structures and aluminium structures — Part 2: Technical requirements for steel structures*

EN 12811-1:2003, *Temporary works equipment — Part 1: Scaffolds — Performance requirements and general design*

EN 12811-2:2004, *Temporary works equipment — Part 2: Information on materials*

EN 12811-3:2002, *Temporary works equipment — Part 3: Load testing*

EN ISO 898-1:1999, *Mechanical properties of fasteners made of carbon steel and alloy steel — Part 1: Bolts, screws and studs (ISO 898-1:1999)*

EN 74-2:2008 (E)

3 Terms and definitions

For the purposes of this document, the terms and definitions given in EN 12811-1:2003 and EN 74-1:2005 and the following apply.

3.1 half coupler (HW, HT)
coupler which connects a tube of 48,3 mm diameter to another member either by means of welding (HW) or by means of a welded-in threaded element (HT)

NOTE See Figures 1 and 2.

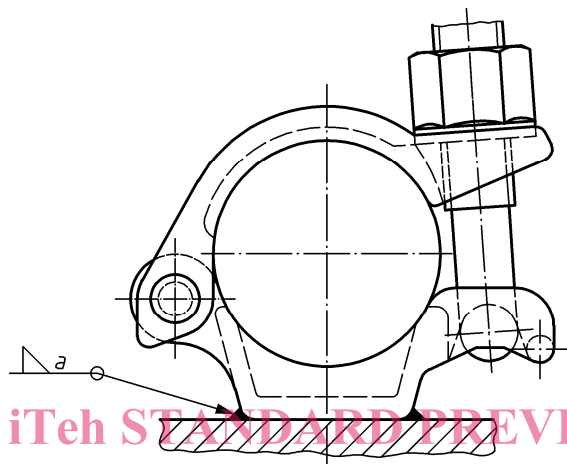

Key

△ a profile of welding

SIST EN 74-2:2008
<https://standards.iteh.ai/catalog/standards/sist/11bc9493-6d6c-4166-fbeb-416ec258d46a6/sist-en-74-2-2008>
Figure 1 — Half coupler connected by welding (HW)

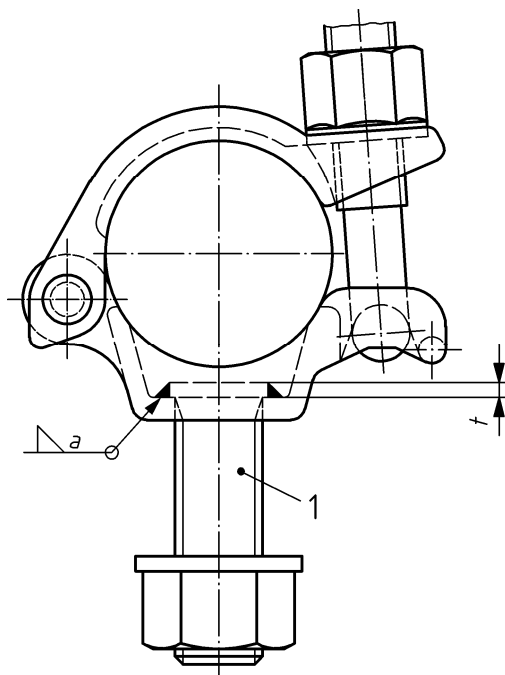
**Key**

- $\triangle a$ profile of welding
 t thickness of the head of welded-in threaded element
 1 welded-in threaded element (bolt, screw, stud, threaded rod)

Figure 2 — Half coupler for connection with a welded in threaded element (HT)

3.2**sleeve coupler with shear studs (SS)**

coupler for connecting 48,3 mm tubes end to end by means of a pair of shear studs on each side engaging with two predetermined holes in each tube

NOTE See Figure 3. Where required, a manufacturer may specify the use of a loose spigot (not shown on Figure 3).

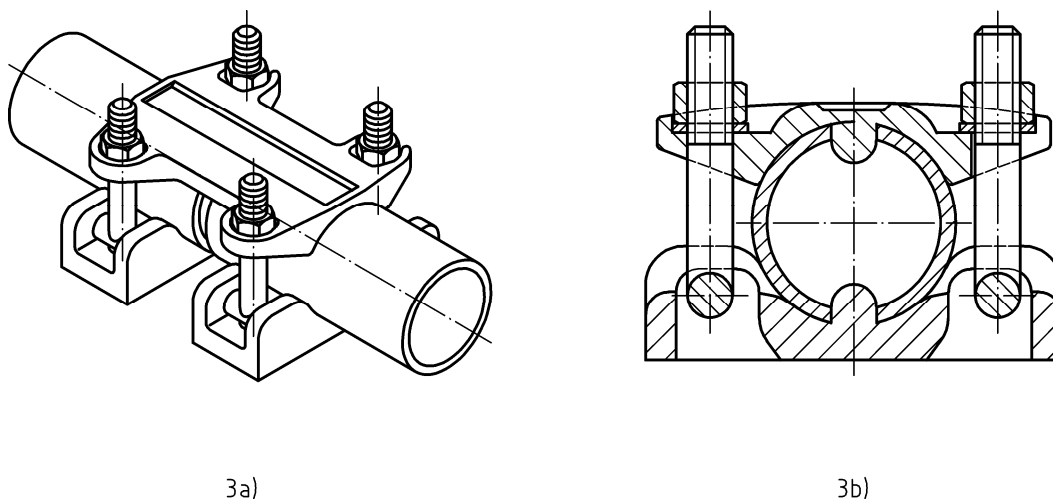

Figure 3 — Sleeve coupler with shear studs (SS)

EN 74-2:2008 (E)

3.3 reduction coupler (RR and RS)
 right angle coupler (RR) or swivel coupler (RS) for connecting two tubes with different diameters of which one tube has a diameter of 48,3 mm

NOTE See Figure 4.

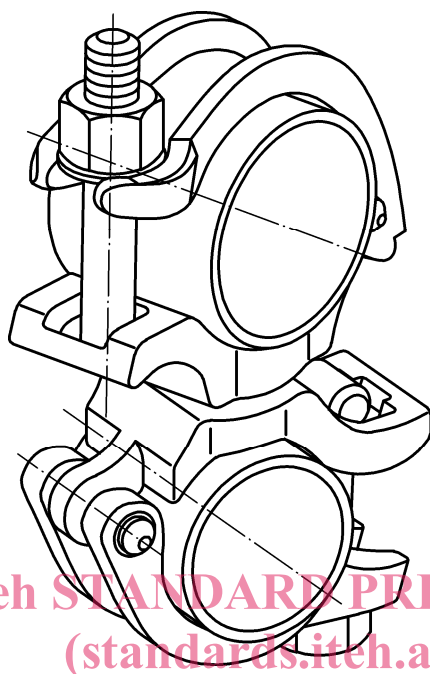

Figure 4 — Reduction coupler as swivel coupler (RS)
<https://standards.iteh.ai/catalog/standards/sist/1bcf9492-6d6e-466f-beb4-16ec258d46a6/sist-en-74-2-2008>

4 Symbols

For the purpose of this European Standard, the following symbols apply:

c_k characteristic stiffness of a longitudinal spring;

F_s slipping force in kN;

F_f failure force in kN;

F_p pull apart force in kN;

F_q share force in kN;

M_B bending moment in kNm;

$c_{\varphi(1),MB}$ bending stiffness in kNm/rad;

$F_{s,c}$ specified value for slipping force in kN;

$F_{f,c}$ specified value for failure force in kN;

$F_{p,c}$ specified value for pull apart force in kN;

$M_{B,c}$	specified value for bending moment in kNm;
$c_{\phi(1),MB,c}$	specified value for bending stiffness in kNm/rad;
v	displacement in millimetres of the transverse tube under load relative to a tube or solid bar in rotational tests;
Δ_i	displacement in millimetres of a coupler under load relative to a tube or solid bar;
Δ_{10}	indentation in millimetres;
P	test load in kN;
P_{ind}	test load for indentation in kN;
$P_{f,ult}$	ultimate failure force in kN;
$P_{p,ult}$	ultimate pull apart force in kN;
$P_{q,ult}$	ultimate share force in kN;
ϕ	specified angle of rotation of a coupler in degrees.

iTeh STANDARD PREVIEW

5 Types and classification of special couplers

(standards.iteh.ai)

The types of special couplers are listed in Table 1.

[SIST EN 74-2:2008](#)

The classification is given in Table 2.

<https://standards.iteh.ai/catalog/standards/sist/1bcf9492-6d6e-466f-beb4-16ec258d46a6/sist-en-74-2-2008>

Table 1 — Types of couplers

Type		Identification	Arrangement
Half coupler		HW	Connection of a tube to a member with a coupler directly welded to the member
		HT	Connection of a tube to a member with a coupler which incorporates a welded in threaded element
Sleeve coupler with shear studs		SS	Tubes connected end to end coaxially using holes in the tubes and studs
Reduction coupler	Right angle	RR	Tube of 48,3 mm diameter connected to a tube of another diameter at a right angle
	Swivel	RS	Tube of 48,3 mm diameter connected to a tube of another diameter at any angle

Table 2 — Classification of couplers

Type of coupler	Class		unclassified
	A	B	
Half coupler	■	■	—
Sleeve coupler with shear studs	—	—	■
Reduction coupler	—	—	■

6 Transmissible internal forces, moments and related stiffnesses

6.1 General

In general a connection between two members is able to transmit three internal forces and three moments at right angle. There are related stiffnesses.

The connection of a tube to another member by a threaded element fixed half coupler (HT) or by weldable half coupler (HW) is designed to transmit three forces. Additionally, a Class B half coupler connected by a welded-in threaded element (HT) is designed to transmit one bending moment and a Class B screw weldable half coupler (HW) is designed to transmit two bending moments as listed in Table 3.

A sleeve coupler with shear studs (SS) is designed to transmit one force and one bending moment as listed in Table 4.

A right angle reduction coupler (RR) is designed to transmit three forces at right angle in three directions as listed in Table 5.

A swivel reduction coupler (RS) is designed to transmit one force as listed in Table 6.

NOTE The influence of the moments resulting from eccentricities of the connection is considered in the test.

6.2 Half coupler

Table 3 shows the structural parameters which are specified.

Table 3 — Structural parameters for half couplers (HT and HW)

Structural parameters (see Figure 5)		Class			
		A	B		
		HW/HT	HW		HT
Screw coupler	Wedge coupler				
Force or moment	Slipping force F_s	■	■	■	■
	Failure force F_f	■	■	■	■
	Pull apart force F_p	■	■	■	■
	Shear force F_q	■	■	■	■
	Bending moment $M_{B,x}$	—	■	—	—
	Bending moment $M_{B,y}$	—	■	■	■
Connection stiffness	Bending stiffness $c_{\phi,MB,x}$	—	■	—	—
	Bending stiffness $c_{\phi,MB,y}$	—	■	■	■

■ Structural parameters are specified in Table 8.

SIST EN 74-2:2008

<https://standards.iteh.ai/catalog/standards/sist/1bcf9492-6d6e-466f-beb4-16ec258d46a6/sist-en-74-2-2008>

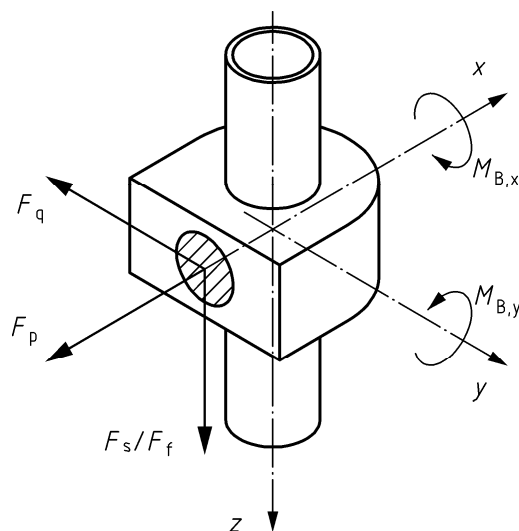

Key

x, y direction of principal axis

Figure 5 — Forces and moments for a half coupler