**Road vehicles — Four-pole electrical
connectors with pins and twist lock —**

**Part 1:
Dimensions and classes of application**

*Véhicules routiers — Connecteurs électriques à quatre contacts avec
broches et verrouillage direct —*
Partie 1: Dimensions et classes d'application

[ISO 15170-1:2001](https://standards.iteh.ai/catalog/standards/sist/f5c35bef-1055-4c58-91f0-c0caeff26aab/iso-15170-1-2001)

[https://standards.iteh.ai/catalog/standards/sist/f5c35bef-1055-4c58-91f0-
c0caeff26aab/iso-15170-1-2001](https://standards.iteh.ai/catalog/standards/sist/f5c35bef-1055-4c58-91f0-c0caeff26aab/iso-15170-1-2001)



PDF disclaimer

This PDF file may contain embedded typefaces. In accordance with Adobe's licensing policy, this file may be printed or viewed but shall not be edited unless the typefaces which are embedded are licensed to and installed on the computer performing the editing. In downloading this file, parties accept therein the responsibility of not infringing Adobe's licensing policy. The ISO Central Secretariat accepts no liability in this area.

Adobe is a trademark of Adobe Systems Incorporated.

Details of the software products used to create this PDF file can be found in the General Info relative to the file; the PDF-creation parameters were optimized for printing. Every care has been taken to ensure that the file is suitable for use by ISO member bodies. In the unlikely event that a problem relating to it is found, please inform the Central Secretariat at the address given below.

iTeh STANDARD PREVIEW
(standards.iteh.ai)

ISO 15170-1:2001

<https://standards.iteh.ai/catalog/standards/sist/f5c35bef-1055-4c58-91f0-c0caef26aab/iso-15170-1-2001>

© ISO 2001

All rights reserved. Unless otherwise specified, no part of this publication may be reproduced or utilized in any form or by any means, electronic or mechanical, including photocopying and microfilm, without permission in writing from either ISO at the address below or ISO's member body in the country of the requester.

ISO copyright office
Case postale 56 • CH-1211 Geneva 20
Tel. + 41 22 749 01 11
Fax + 41 22 749 09 47
E-mail copyright@iso.ch
Web www.iso.ch

Printed in Switzerland

Foreword

ISO (the International Organization for Standardization) is a worldwide federation of national standards bodies (ISO member bodies). The work of preparing International Standards is normally carried out through ISO technical committees. Each member body interested in a subject for which a technical committee has been established has the right to be represented on that committee. International organizations, governmental and non-governmental, in liaison with ISO, also take part in the work. ISO collaborates closely with the International Electrotechnical Commission (IEC) on all matters of electrotechnical standardization.

International Standards are drafted in accordance with the rules given in the ISO/IEC Directives, Part 3.

The main task of technical committees is to prepare International Standards. Draft International Standards adopted by the technical committees are circulated to the member bodies for voting. Publication as an International Standard requires approval by at least 75 % of the member bodies casting a vote.

Attention is drawn to the possibility that some of the elements of this part of ISO 15170 may be the subject of patent rights. ISO shall not be held responsible for identifying any or all such patent rights.

ISO 15170-1 was prepared by Technical Committee ISO/TC 22, *Motor vehicles*, Subcommittee SC 3, *Electrical and electronic equipment*.

ISO 15170 consists of the following parts, under the general title *Road vehicles — Four-pole electrical connectors with pins and twist lock*:

— *Part 1: Dimensions and classes of application*

[ISO 15170-1:2001](#)

— *Part 2: Tests and requirements*

<https://standards.iteh.ai/catalog/standards/sist/f5c35bef-1055-4c58-91f0-c0caeff26aab/iso-15170-1-2001>

iTeh STANDARD PREVIEW
(standards.iteh.ai)

iTeh STANDARD PREVIEW
(standards.iteh.ai)

ISO 15170-1:2001

<https://standards.iteh.ai/catalog/standards/sist/f5c35bef-1055-4c58-91f0-c0caef26aab/iso-15170-1-2001>

Road vehicles — Four-pole electrical connectors with pins and twist lock —

Part 1: Dimensions and classes of application

1 Scope

This part of ISO 15170 specifies those items, principally dimensions and classes of application of electrical connectors with up to four pins and twist lock coupling, necessary for assuring the interchangeability of both parts of electrical connections according to ISO 15170.

This type of connection is intended for electrical connections in truck, bus and trailer applications (e.g. for components directly mounted on the engine).

iTeh STANDARD PREVIEW
(standards.iteh.ai)

2 Normative references

The following normative documents contain provisions which, through reference in this text, constitute provisions of this part of ISO 15170. For dated references, subsequent amendments to, or revisions of, any of these publications do not apply. However, parties to agreements based on this part of ISO 15170 are encouraged to investigate the possibility of applying the most recent editions of the normative documents indicated below. For undated references, the latest edition of the normative document referred to applies. Members of ISO and IEC maintain registers of currently valid International Standards.

ISO 8092-4:1997, *Road vehicles — Connections for on-board electrical wiring harnesses — Part 4: Pins for single- and multi-pole connections — Dimensions and specific requirements*

ISO 15170-2:2001, *Road vehicles — Four-pole electrical connectors with pins and twist lock — Part 2: Tests and requirements*

3 Dimensions

The dimensions of the connector shall be according to those shown in Figures 1, 2 and 3.

Details unspecified are left to the manufacturer's choice.

The free coupler connectors shall be manufactured such that the coupled arrangement of both connectors fulfils the requirements of ISO 15170-2.

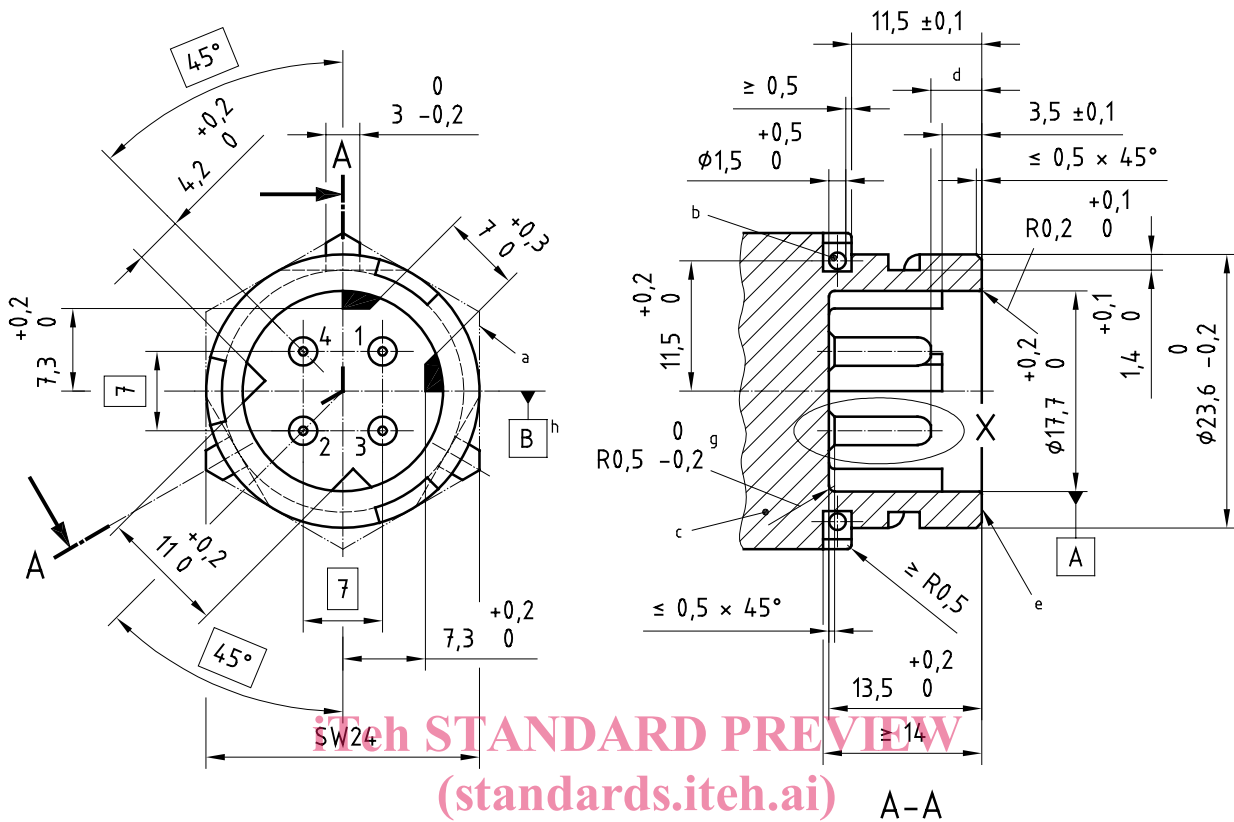

STANDARD PREVIEW
(standards.iteh.ai) A-A

ISO 15170-1:2001
<https://standards.iteh.ai/catalog/standards/sist/f5c35bef-1055-4c58-91f0-c0caeff26aab/iso-15170-1-2001>

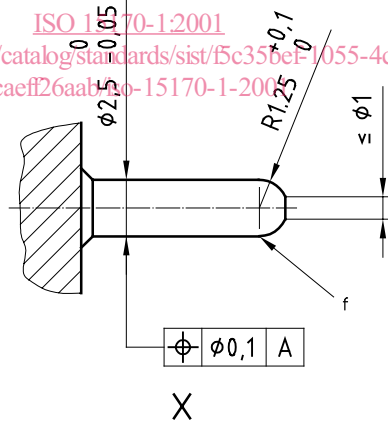

- a Different contours are permitted.
- b Hole for security device. The outer contour of the eye shall be within the contour of the 24 mm hexagon.
- c Dimensions, sealing and cable retention at manufacturer's discretion.
- d Type A: (4,5 ± 0,1) mm; type B: (4,5^{+0,5}_{-0,4}) mm.
- e Sealing area (i.e. no burrs or ridges permitted).
- f No transition area.
- g Circular.
- h See Figure 2.

Figure 1 — Type A, fixed, and type B, free, connector dimensions (with preferred code 1)

Dimensions in millimetres

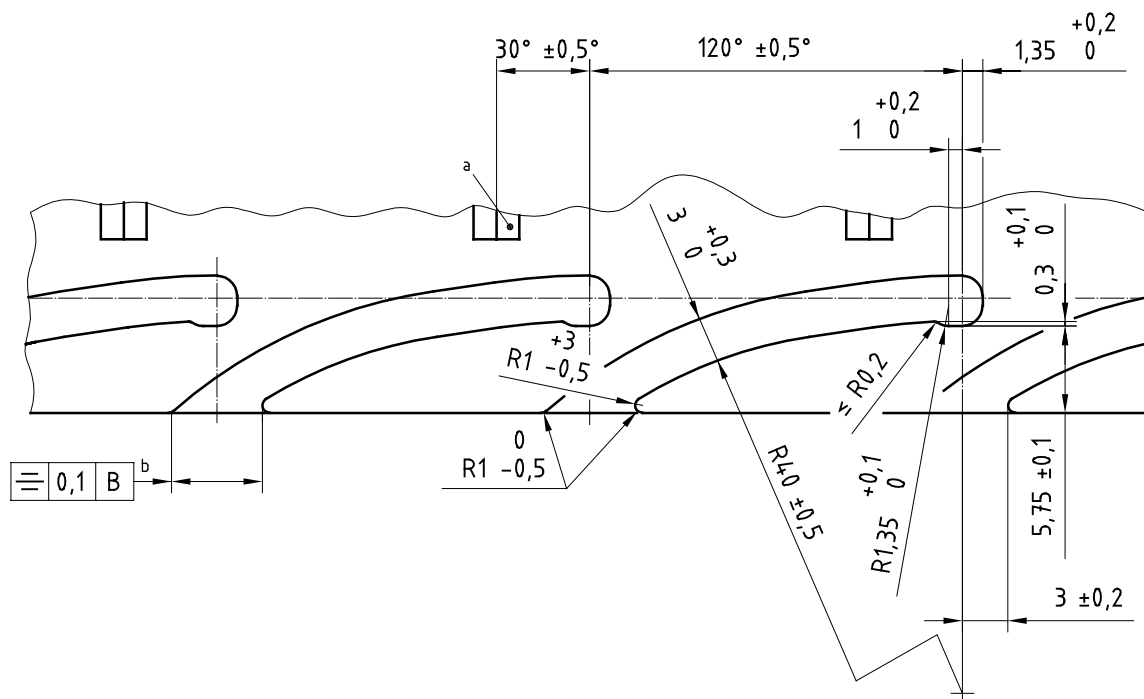

- a Seal eye.
- b See Figure 1.

iTeh STANDARD PREVIEW
(standards.iteh.ai)

Figure 2 — Twist lock development at bottom of groove

ISO 15170-1:2001

<https://standards.iteh.ai/catalog/standards/sist/f5c35bef-1055-4c58-91f0-c0caeff26aab/iso-15170-1-2001>

Dimensions in millimetres

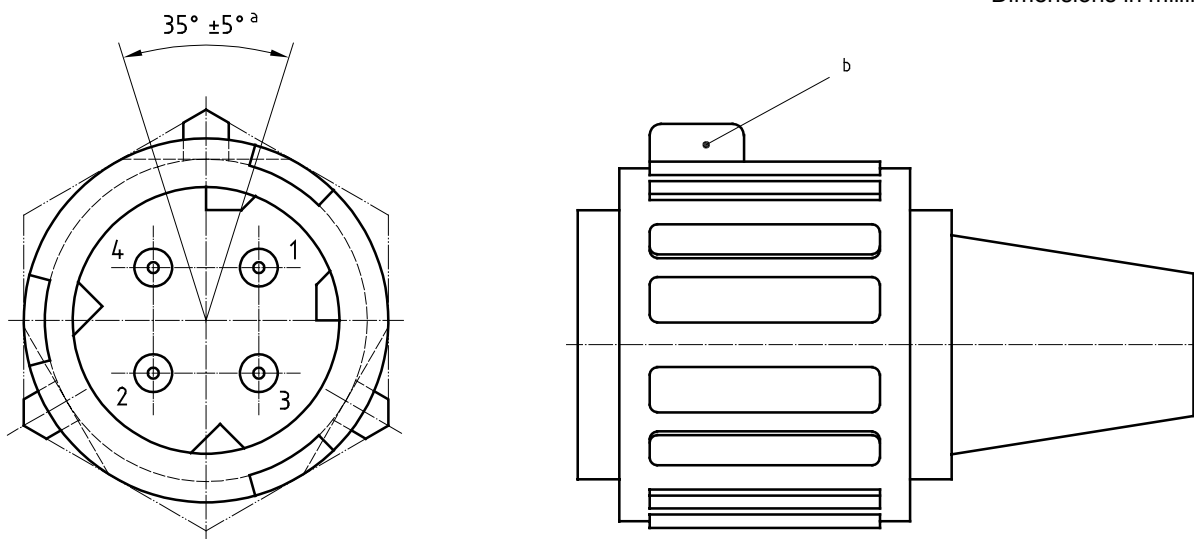

a) Marking zone at fixed or free connector

b) Marking at free coupler connector

- a Zone for positive marking.
- b Positive marking of coupling ring position ready for connection.

Figure 3 — Marking

4 Classes of application

The classes of application K1, K2 and K3 are specified in Table 1.

Table 1 — Classes of application

| Class | Material of contact surface (plating) | Contact temperature range °C | Max. acceleration of vibrations m/s ² |
|-------|---------------------------------------|---------------------------------|---|
| K1 | Sn | – 40 to + 120 | 200 |
| K2 | Sn | – 40 to + 120 | 300 |
| K3 | Ag | – 40 to + 140 ^a | 300 |

^a Higher temperatures are to be agreed between manufacturer and user.

5 Designation

EXAMPLE 1 Fixed connector (type A) with preferred coding (1), three contacts fitted, with contact numbers 1, 2 and 3 (3.1: see Table 2), equipped with tin-plated (Sn) contacts, and withstanding class K1:

Connector ISO 15170 - A1-3.1-Sn/K1

EXAMPLE 2 Free connector (type B) with preferred coding (1), two contacts fitted, with contact numbers 1 and 3 (2.2: see Table 2), equipped with silver-plated (Ag) contacts for crimp size coding 1, and withstanding class K3:

Connector ISO 15170 - B1-2.2-1-Ag/K3

6 Coding

<https://standards.iteh.ai/catalog/standards/sist/f5c35bef-1055-4c58-91f0-c0caeff26aab/iso-15170-1-2001>
 ISO 15170-1:2001
 (standards.iteh.ai)

Table 2 presents the coding of pole arrangements, with the preferred variants.

If, in this table, the variety of codes provided by the different contact allocations with code 1 is insufficient, the following mechanical codings shall be used in the sequence given.

- a) Colour coding as specified in Figure 4 shall be applied. Colour coding is not required for the lock ring.
- b) Additional coding may be applied as agreed between manufacturer and user.
- c) For connecting devices where the polarity of the d.c. supply is essential, pole number 1 shall be used for the positive polarity.

Table 2 — Coding of pole arrangement
(bold signifies preferred variants; see 7.4 for symbol meanings)

| No. of poles | Designation of poles | | | | Code |
|--------------|-----------------------|-----------------------|-----------------------|-----------------------|------------|
| | 1 | 2 | 3 | 4 | |
| 2 | X | X | – | – | 2.1 |
| | X | – | X | – | 2.2 |
| | X | – | – | X | 2.3 |
| | – | X | X | – | 2.4 |
| | – | X | – | X | 2.5 |
| | – | – | X | X | 2.6 |
| 3 | X | X | X | – | 3.1 |
| | X | X | – | X | 3.2 |
| | X | – | X | X | 3.3 |
| | – | X | X | X | 3.4 |
| | X ⁺² | X | X ⁺² | – | 3.5 |
| | X | X ⁺¹ | – | X ⁺¹ | 3.6 |
| 4 | X | X | X | X | 4.1 |
| | X | X ⁺¹ | X | X ⁺¹ | 4.2 |
| | X ⁺² | X | X ⁺² | X | 4.3 |
| | X⁺² | X⁺¹ | X⁺² | X⁺¹ | 4.4 |

ISO 15170-1:2001
<https://standards.iteh.ai/catalog/standards/sist/f5c35bef-1055-4c58-91f0-c0caeff26aab/iso-15170-1-2001>

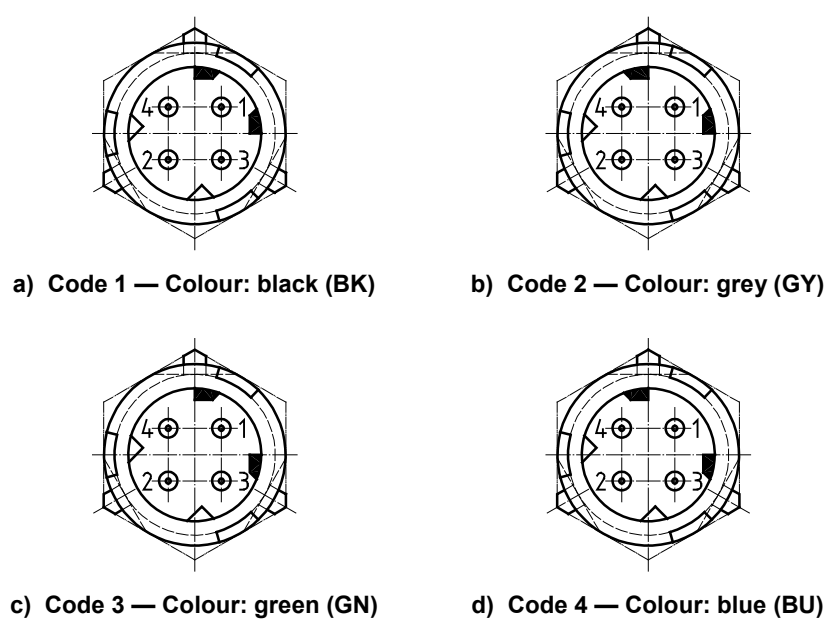

Figure 4 — Mechanical and colour coding